

## Active material application for shock and impact energy absorption

R. Bansevicius, V. Blechertas, R. T. Toločka

Kaunas University of Technology

### Introduction

Engineering materials have gone a long way from simple structural to active ones. Recent advances in the development and application of active materials, including extremely effective piezoactive or magnetostrictive compounds, electro/magneto rheological fluids and shape memory alloys (e.g. PZT, PVDF, Terfenol or PMN) have increased the level of integration and multifunctionality of mechatronic systems and devices and extended the area of application.

A wide variety of active and semi-active oscillation protection systems are available at present, but their development remains actual. Application of active materials, e.g. piezomaterials and rheological fluids, are promising in this field and there are a lot of works contributing to it [1-7].

Oscillation suppression by piezoactive materials is well developed (see Volkovas [1], etc.) and has a number of successful applications. They offer key benefits over other more traditional oscillation suppression systems: may be tuned to aim at specific frequencies of importance, are effective over a broad temperature range, embedded modules are easy to integrate and they are highly reliable.

Electro/magnetorheological fluids are applied in semi-active oscillation suppression systems due to their property to change viscosity under the action of variable external electrical magnetic field [2, 5, 7].

Piezoactive materials possess actuating and sensing possibilities, allowing the fabrication of smart integrated sensing/actuating systems. Composite structures consisting of electrorheological fluids and piezoelectric ceramics feature self-tuning properties. The piezoelectric ceramics respond to outside oscillations, providing an electrical field to change the viscosity of electrorheological fluid [4, 5].

### Active material application for shock and impact energy absorption

The active material application for absorption of shock and impact energy has not been explored thoroughly yet, although there are many possibilities for their application in industry as well as in other areas. Sports engineering area, among these, can be mentioned as one of the most challenging. Examples here would be adaptive shoes [6], providing optimal interaction between ground surface and the athletes feet in footprints, or golf-clubs with controllable impact restoring characteristics, etc.

One possibility consists in the control of some parameters, e.g., friction with fast response, by introducing the oscillations of high frequency in the kinematic pair's contact elements. It makes possible to control the structure of impact systems widely used in industry [3]. The schematic of such a system is shown in Fig. 1, where  $m_1$  is

fixed to a cylindrical piezoceramic actuator/sensor, contacting with the mass  $m_2$ . Thus the mass of the "hammer" is  $(m_1+m_2)$ , after reaching specific impact force value, defined by  $\theta(x,t)$  or rheological properties of contacting surfaces, resonant oscillations of the piezoelectric actuator are generated, reducing the friction between the cylinder and the mass the  $m_2$ . Now the mass of the "hammer" is  $m_1$  and a value of impact force is reduced. The duration of a friction control time will be determined by natural frequencies of the piezoelectric transducers and will lie in the range of 0.1...0.5 ms.

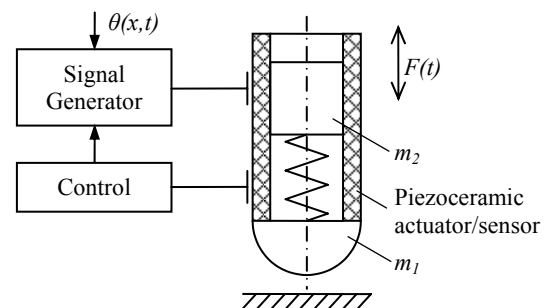

Fig. 1. Controlling the structure of impact system

Control of shock energy dissipation parameters is another possibility. It can be realized as conversion into electric energy in a piezomaterial, where application of additional electric circuits for the alteration of damping parameters enables control of the process. For example, the amount of electric charge generated by striking with a golf-club, (Fig.2) allows for obtaining current information on the value of the striking power and the possibility to control the impact restoring characteristics by controlling the rheology of the contact surfaces by changing the electric circuit parameters.

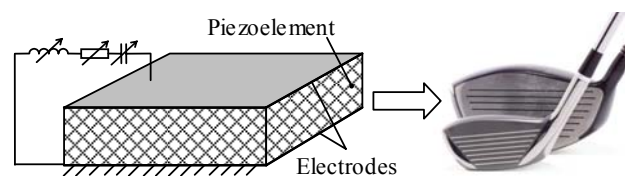

Fig. 2. Smart golf-club

A few experiments were made showing effectiveness of such systems for impact caused vibration attenuation. The glass fibre plate (130x170x1 mm), with the piezobimorph element (60x10x2 mm) glued to its surface, was excited at the 183 Hz resonant frequency. Then the passive external resonant electrical circuit (Fig. 3) ( $L = 111$  H,  $R = 3.04$  k $\Omega$ ) was connected to piezobimorph, resulting in 60 % vibration amplitude decrease (Fig. 4a).

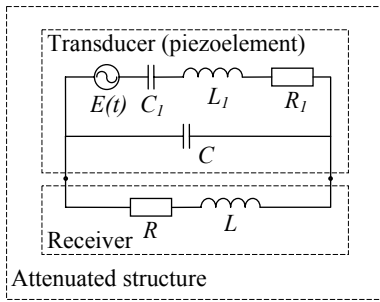
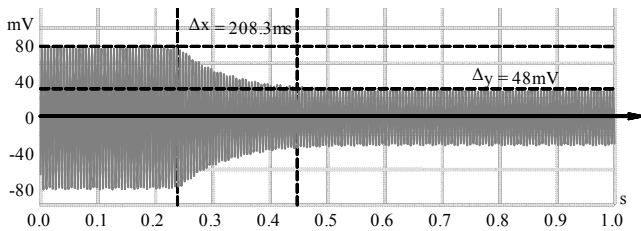
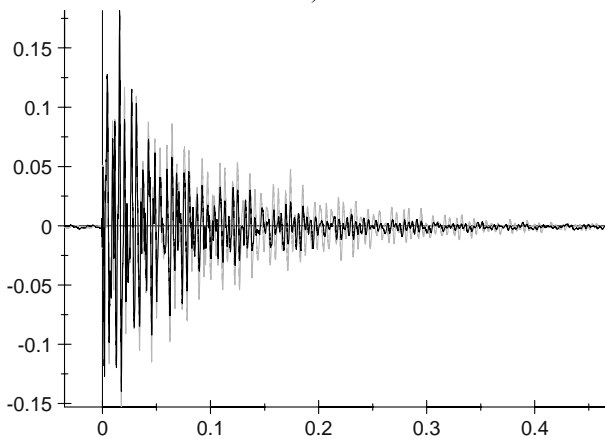

Fig. 3. Equivalent circuit of the tested system

The same system was tested by hitting it with a rubber hammer. Fifty percent decrease in impact caused vibration amplitude was measured (Fig. 4b), though it was not very efficient at the initial plate and hammer contact instant.



a)



b)

Fig. 4. Decrease of vibrations after connecting the passive electrical circuit

The coefficient of impact restitution may be controlled by changing the phase of oscillations of a contacting piezoelectric bar (Fig. 5).

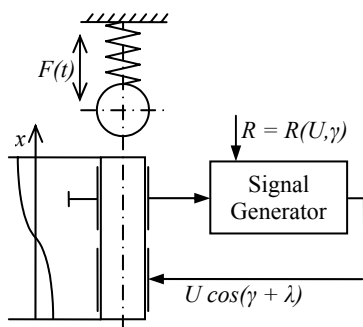

Fig. 5. Coefficient of restitution control, using piezoceramics

Shock energy dissipation also can be controlled by means of alternating the strength of the electric field, which activates the electrorheological fluid.

Other possibility is to use composite structures containing piezomaterial and electrorheological fluids. This allows the design of shock and impact energy absorbing systems with self-tuning properties and functioning on internal sources of energy. The principle scheme is shown in Fig. 6.

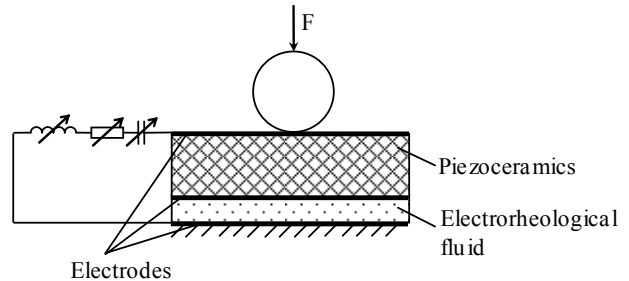

Fig. 6. Composite structure of active materials

The structure shown in Fig. 4 consists of piezomaterial and electrorheological fluid under it. The electric charge is generated at the shock to the piezomaterial and the voltage occurs between electrodes. Under the action of the electric field generated the viscosity of the electrorheological fluid changes, alternating the dissipation of the shock energy. The additional parallel electric circuits, with variable parameters, allow setting of the necessary dissipation parameters.

### Conclusions

1. Active materials are promising in the field of oscillation, shock and impact suppression, but their application for the second including process control remains a challenge.

2. The active materials, i.e. piezomaterials, allow effectively control the process of shock and impact energy dissipation by exploiting additional electric circuits.

3. The composite structures consisting of piezomaterials and electrorheological fluids allow to design shock and impact energy dissipation systems with self tuning properties and functioning without any external energy sources.

### References

1. Volkov V. V., Pashkevichius P. P, Ragulskis K. M., Rimsha G. E. Energy conversion mechanisms and their application to motion stabilization. The theory of machines and mechanisms. Proc. of 7<sup>th</sup> World Congress, eds. E. Bautista, J. Garcia-Lomas, & A.Navvaro. Pergamon Press. 1987. Vol. 2. P.837-840.
2. Sang Hwa Kim, Youngjin Park. Constrained rotary MR damper design and its application, MOVIC'98. Proc. of Int. Conf., Zurich, Switzerland. 1998. Vol.2. P.641 – 646.
3. Stevens N. G., Sproston J. L., Stanway R. Experimental evaluation of an electroviscous damper. Electrostatics. 1984. No.20. P.167-184.
4. Bansevicius R., Tolocka T. Adaptive mechanisms in mechatronics: parameters and structure control. Proc. of International Conf MECHATRONIKA'97. Meander S.C., Warsaw, Poland. 1997. Vol.2. P.411-415.

5. **Tang Hong, Zhao Xiapeng, Liu Shu.** Design and performance research of an adaptive damper composed of electrorheological fluids and piezoelectric ceramics. Smart materials and structures. 2003. No.12. P.347 – 354.  
[http://www.computer.org/micro/homepage/may\\_june/shenck/01.htm](http://www.computer.org/micro/homepage/may_june/shenck/01.htm)
6. **Jolly M. R., Carlson J. D.** Controllable squeeze film damping using magnetorheological fluid. Actuator 96. Proc. of 5<sup>th</sup> Int. Conf. on New Actuators. Bremen, Germany. 1996. P.333 - 336.

R. Bansevicius, V. Blechertas, R. T. Toločka

#### **Aktyviųjų medžiagų naudojimas smūgio energijai sugerti**

##### Reziumė

Tobulinti mechaninės energijos sugėrimo priemonės yra aktualu kuriant šiuolaikines virpesių ir smūgio slopinimo sistemas. Aktyviosios medžiagos, galinčios paversti mechaninę energiją į kitos rūšies energiją ir ją išsklaidyti, yra daug žadančios šioje srityje. Kaip šios medžiagos naudojamos virpesiams slopinti, plačiai nagrinėta, tačiau kaip smūgiui slopinti, - nepakankamai. Straipsnyje aptariamos pasyvios virpesių ir smūgio slopinimo/valdymo sistemos, kuriose naudojamos pjezoaktyviosios ir elektoreologinės medžiagos ar jų kompozitai. Pateikiami eksperimentiniai rezultatai, rodantys tokių sistemų veiksmingumą.

Pateikta spaudai 2004 10 25

DOI: 10.5755/j01.u.53.4.16915