

Non-destructive testing of sheet product inner surfaces using longitudinal surface acoustic waves

S. Sajauskas, A. Valinevičius, L. Miežutavičiūtė

Department of electronics engineering, Kaunas University of Technology

Studentų 50, LT-51368 Kaunas

Introduction

Excitation of secondary longitudinal surface acoustic waves (LSAW II) on the opposite side of the plate during propagation of primary LSAW (LSAW I) [2, 3] on the first surface is one of the exceptional features of LSAW [1-3]. That permits analysis and detection of surface defects located on inaccessible inner surface of the sheet products, such as tanks, reservoirs, boilers and also nuclear reactor components [4, 5], using secondary LSAW. There are some reservations about application possibilities of the secondary LSAW in non-destructive tests under real conditions, considering natural attenuation of LSAW, highly exceeding attenuation of Rayleigh waves.

The purpose of this work was to investigate experimentally the parameters of the real secondary LSAW signals and to determine the potential limits for shell product inner surface analysis.

Investigation methodology and equipment

It was experimentally determined that LSAW are excited most effectively using variable angle prismatic transducers [6, 7]. The earlier described digital ultrasonic defectoscope was used in experiments; it incorporates 2-4 MHz variable angle prismatic piezoelectric transducers [7]. The secondary LSAW (LSAW II) excitation and investigation scheme for this case is shown in Fig. 1.

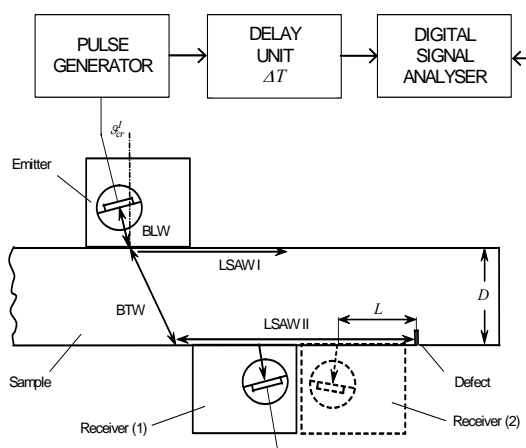

Fig. 1. LSAW II experimental investigation scheme

The angle emitter matched for the first critical angle g_{cr}^I is excited using the pulse generator and it generates LSAW I in the test sample. Bulk transversal waves (BTW) propagate and at the same time generate LSAW II on the opposite side. During investigation these waves can be

picked up by the angle receiver placed on the inner surface of the product.

Notches of 1 mm width and of the different depth (from 2 to 4 mm) are made on the inner surface in order to simulate the defects. The receiver placed on the bottom position is turned around by 180° (Fig. 1, dashed line) in order to receive the LSAW II, reflected from the notch.

Features of LSAW signal pick-up using angle transducer

Reception of the LSAW signals by the variable angle transducer is associated with a series of problems. One of them is the duplication of the acoustic pulse excited by a piezoelement generating the plane bulk longitudinal wave (BLW). Duplication of the acoustic pulse is due to the small LSAW excitation angle

$$g_{cr}^I = \arcsin(c_L' / c_L''), \quad (1)$$

where c_L' and c_L'' are velocities of bulk longitudinal wave in the angle transducer prism and the sample respectively. For example, the LSAW is generated in duralumin ($c_L''=6320$ m/s) products using the transducer with the prism, manufactured of plexi glass ($c_L'=2730$ m/s), $g_{cr}^I=25.6^\circ$. In the case when the dimension of the piezoelement generating the plane BLW $d \gg \lambda_L$, where λ_L is the length of the longitudinal waves in the prism, conditions may arise for excitation of piezoelement repeatedly by the reflected BLW pulse (Fig. 2).

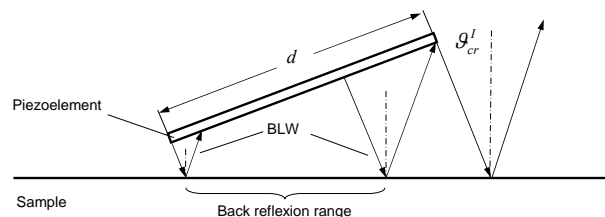

Fig. 2. Scheme of repeated excitation of piezoelement

The LSAW pulses of an identical shape are generated because of repeated excitation of the piezoelement by the BLW pulse, reflected from the surface of the sample (Fig. 3). Besides, the magnitude of the second LSAW pulse may be sometimes even higher than of the first, although it is created by the pulse reflected from the surface of the test sample, consequently weaker than the first BLW pulse. This paradox is explained in the following way. First, when piezoelement is excited by the electric pulse the it

emits the acoustic pulse, shape of which is determined by piezoelement pulse response. Thus, shape of the BLW pulse reflected from the surface ideally matches the pulse response of the piezoelement; for this reason efficiency of the repeated excitation (acoustic) is maximal. Second, if the transducer incidence angle ϑ is not exactly equal to ϑ_{cr}^I , then the LSAW II pulse may be emitted at the angle, closer to ϑ_{cr}^I , therefore, it may be stronger than the first one.

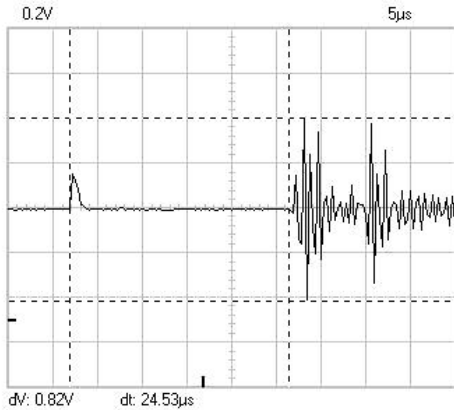

Fig.3. Duplicated LSAW signal, generated as a result of repeated excitation of the piezoelement. Thickness of the sample $D=40\text{mm}$

The second pulse of the BLW signal may be eliminated increasing piezoelement distance from the radiating prism plane, using standard double transducers with an acoustic delay and an additional prism (Fig. 4). However, in such case transducers sensitivity would decrease and transducers dimensions would increase due to the increased BLW attenuation in the prism.

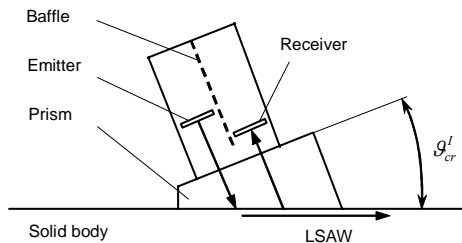

Fig. 4. LSAW angle transducer with additional prism

Noticeably, the duplication of acoustic signal does not influence measurements or non-destructive testing using LSAW. It can be even useful as an indication that received acoustic signal is the LSAW signal, not a lateral reflection of the BLW in an angle transducer prism or in the analyzed sample.

Another lateral effect, natural to investigations of LSAW, is associated with back radiation (pick-up) of the angle type transducer. It was found experimentally that the angle type transducer radiates (receives) LSAW not only in the forward direction, but also in the reverse direction. The measured ratio of transducer sensitivities in the forward and the reverse directions is 23.5 dB. Collateral forward LSAW pulses can be seen on oscilloscope display due to reception in the reverse direction, when the LSAW signals,

reflected from the defect, are received using the experimental set-up, shown in Fig. 1. They are observed in the time domain earlier than the LSAW pulses reflected from the defect, which have traveled a longer distance (Fig. 5).

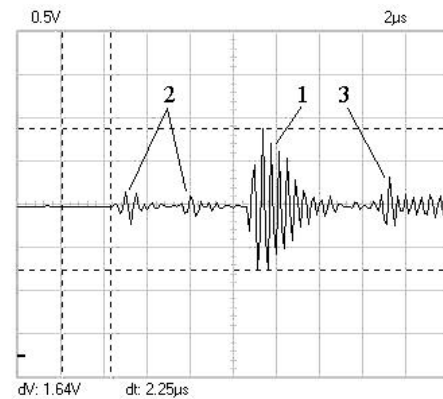

Fig. 5. LSAW signal on the display of a digital oscilloscope: 1 – LSAW, pulse, reflected from the defect; 2 – duplicated collateral (forward) LSAW pulses, picked by the receiver in the reverse direction; 3 – repeated piezoelement excitation pulse, reflected from the defect

Especially negative factor is that collateral pulses are the first on the time axis. Interpretation of a complex signal can be complicated and may lead to non-destructive testing errors, if collateral reverse reception signals are significant in a magnitude. In such cases unwanted reverse reception signals can be eliminated using the angle transducer with two identical piezoelement (Fig. 6) and introducing the reception channel, using electronic gate blocking for a time interval

$$\Delta t \geq 2(\Delta t_{1L} + \Delta t_{1T}) + 2(\Delta t_{2L} + \Delta t_{2T}) + \Delta t_{PIB}^{\text{II}}, \quad (2)$$

where Δt_{1L} and Δt_{2L} are respectively the first piezoelement (emitter) radiated and the second piezoelement (receiver) received BLW pulse delay times in the prism; Δt_{1T} and Δt_{2T} are respectively the first and the second piezo-crystal BTW pulse delay times in the sample; $\Delta t_{PIB}^{\text{II}}$ is the delay time of the LSAW II signals, when they propagate between the points A and B.

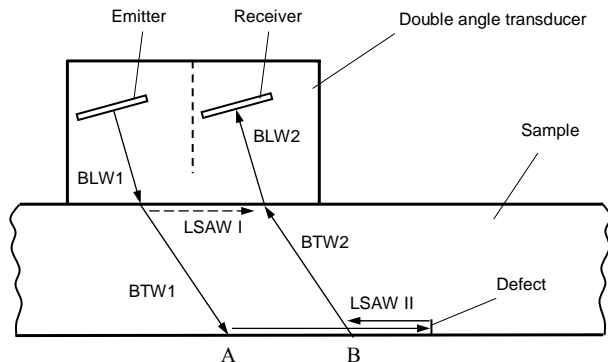

Fig. 6. Double angle transducer

In this case the LSAW signal, reflected from the surface defect or sample edge is the first received ultrasonic signal, observed on an oscilloscope display.

Results of experimental investigations

Set-up used for experimental investigations is shown in Fig. 1. After determining the value of the first critical angle $\vartheta_{cr}^I = 25.6^\circ$, two identical fixed angle transducers were made where the piezoelement are acoustically damped. The transducer maximum sensitivity frequency is 2,5 MHz. LSAW-II signal excited by one of these transducers and received by another on is shown in Fig. 7.

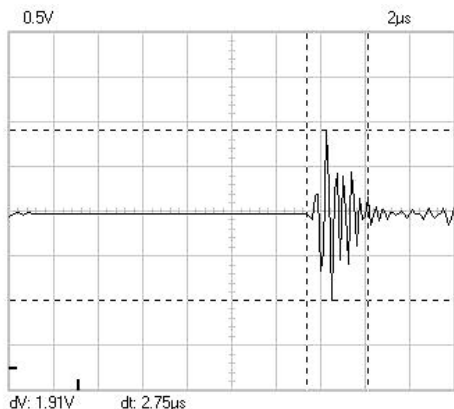

Fig.7. LSAW II signal received by the angle transducer (1) at 2.5MHz, propagating in the forward direction

When pick-up transducer is turned around by 180° , the LSAW II signals reflected from the artificial defect (1 mm width, $h=2$ mm depth notch) are registered by it, and the different distances from the defect are selected (Fig. 8). The first two lower magnitude pulses are collateral LSAW II signals, propagating in the direction of the defect and received by the reverse side of the angle transducer. When the transducer is moved closer to the defect, the LSAW II signal reflected from it moves along sweep origin direction, and when $L=0$ its magnitude is maximal (Fig 8, b). When the transducer is behind the defect, there is no LSAW II signal, reflected from the defect; only duplicated collateral pulses are left (Fig 8, d).

When the inner surfaces of sheet type products are investigated using LSAW II, these waves have to be excited and received up from the outer surface side by the same angle transducer or using the double transducer (Fig. 4, 6). Scheme of such investigation is shown in Fig. 9, and the LSAW II signal reflected from the defect – in Fig. 10.

In this case there are no signals received by the reverse side of pick-up element. Although LSAW II signal and the hardware interference ratio (16...24 dB) is less than during investigation using two separate transducers (~40 dB), it is still sufficiently large to register the defect reliably.

In the sheet sample with the thickness $D=10$ mm, due to multiple signal reflections between the walls and due to small BTW attenuation in duralumin, the received acoustic signal is strong and consists of long series of LSAW II waves, reflected from the defect (Fig. 11). This indicates, that it could be possible to use higher than 2.5 MHz frequency angle transducers for sheet products, which would allow to increase the investigation accuracy and to detect smaller defects.

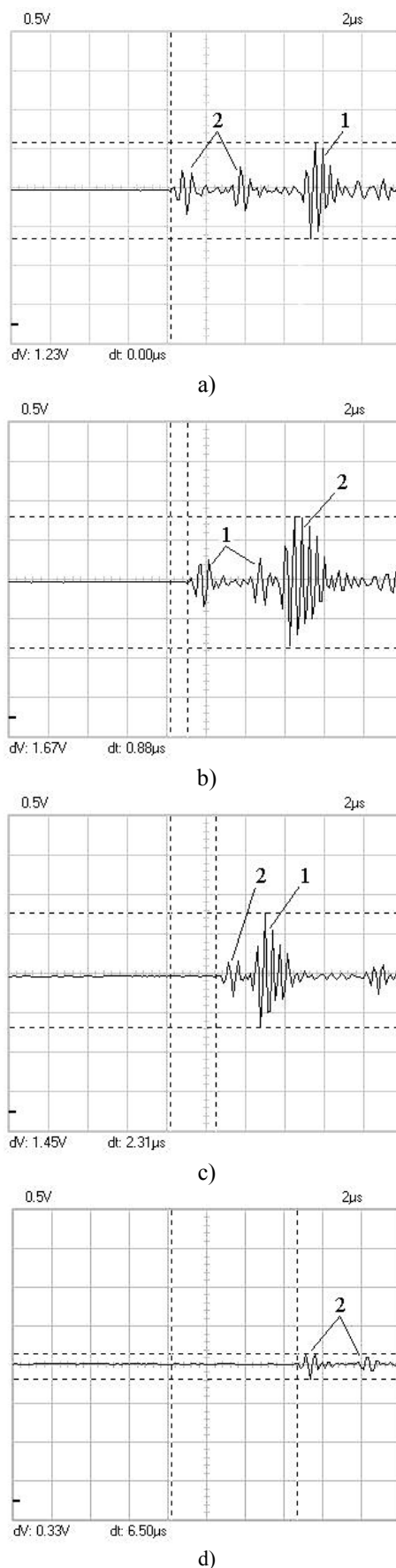

Fig.8. LSAW II signals (1), reflected from the sample notch ($h=2$ mm); signals (2) received at the reverse direction of transducer. Distance L from pick-up aperture center to defect: a) +4 mm; b) 0 mm; c) -19 mm; d) -48 mm

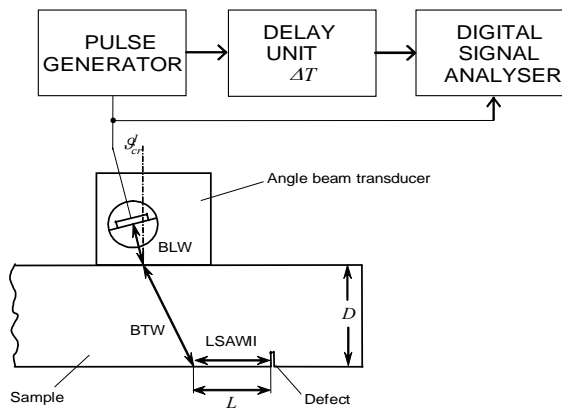
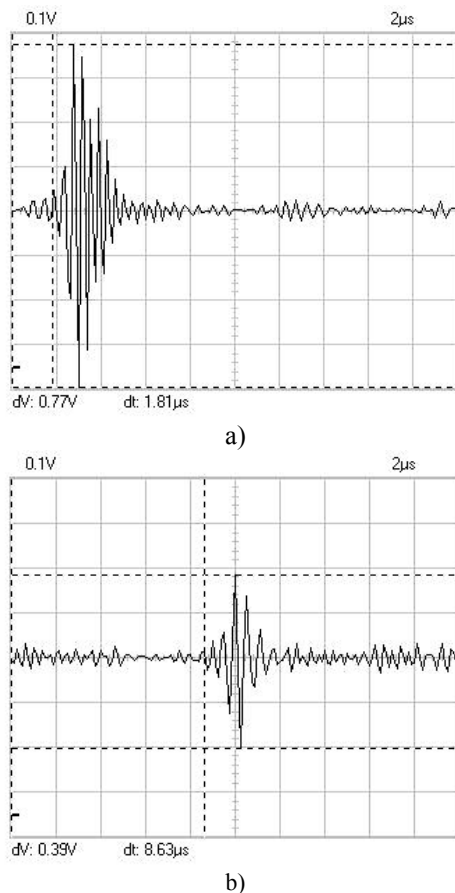

Fig. 9. Scheme of inner surface investigation using LSAW II

Fig.10. LSAW II signal, reflected from the inner defect, when $D = 40$ mm and the distance L : a - 0 mm; b - 20 mm

It should be noticed, that only a part of LSAW II energy is reflected from 2 mm depth notch (defect), and the magnitude of the received LSAW II signal is significantly greater (~ 3 dB) when defect is deeper ($h=4$ mm) (Fig. 11, b). That confirms LSAW property to propagate in a near-surface layer.

Since the angle type transducer radiates directional LSAW, it is naturally that the magnitude of the signal reflected from a regular shape defect (smooth notch) depends on the defect orientation with respect to the LSAW propagation direction. Therefore, detection

probability of defects of such nature is higher for the defects, orientation of which can be foreseen (e. g., for defects along welding juncture). The described investigations were performed by the angle transducer, directional characteristic width of which in the plane of sample surface measured at the 3 dB level was $3...4^\circ$.

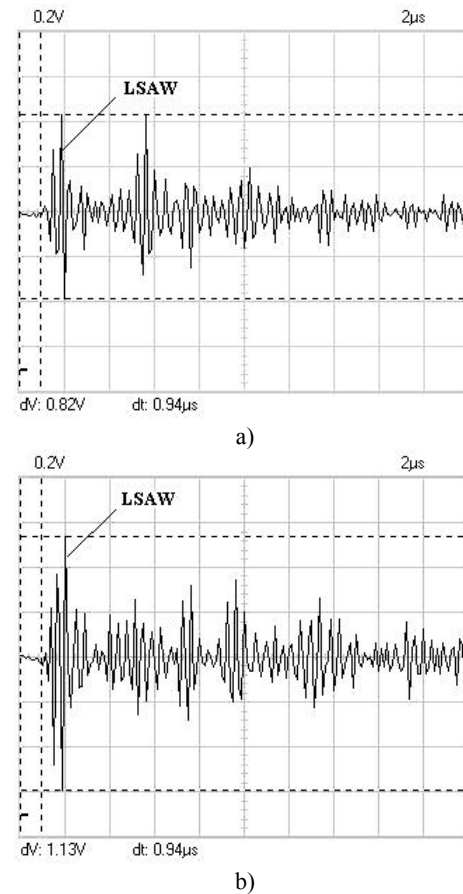
Fig.11. LSAW II signals, reflected from notch in plate with thickness $D=10$ mm. Depth of notch (defect) h : a - 2 mm; b - 4 mm.

Conclusions

1. The level of LSAW II signals excited and picked up by angle transducers is less than the level of LSAW I by 10...15 dB, but it is still sufficient in order to perform non-destructive ultrasonic testing of shells and inner walls of sheet type product (tanks, boilers).
2. Double angle transducers are the most efficient for registration of LSAW II in products with known acoustic properties.
3. LSAW II non-destructive testing is more efficient for investigation of regular shape defects (cracks) with predictable orientation, for example, along welded joint.

References

1. Sajauskas S. Electroacoustical investigation method of isotropic solids. Kaunas: Technologija. 1994. P. 320. (In Lithuanian).
2. Sajauskas S. Longitudinal surface acoustic waves. Kaunas: Technologija. 2002. P. 160. (In Lithuanian).
3. Sajauskas S. Longitudinal surface acoustical waves (creeping waves) Kaunas: Technologija. 2004. P. 176. (In English).

4. **Erhard A., Wüsterberg H., Engl G, Kutzner J.** Reliability and redundancy in ultrasonic flaw sizing methods NDT in the nuclear industry 1980. Metals Park: ASM. 1981. P. 255-268.
5. **Möhler P., Röhrlich H.** Rechnergesteuerte Ultraschall-Prüftechnik zur automatischen Untersuchung von Kernreaktor-Komponenten im Rahmen der Fertigungsprüfung. Materialprüfung. 1983. B. 25. Nr. 3. S. 66-69.
6. **Sajauskas S.** The problem of excitation of longitudinal-surface acoustic waves. Ultrasound. 2002. N. 2(43). P. 17-20 (In Lithuanian).
7. **Sajauskas S., Minialga V.** Experimental investigation of interaction of longitudinal surface acoustic waves or transversal surface waves and external corner. Ultrasound. 2002. N.1(42). P. 42-45 (In Lithuanian).

S. Sajauskas, A. Valinevičius, L. Miežutavičiūtė

Plonasienių gaminių vidinių paviršių neardomieji tyrimai paviršinėmis išilginėmis bangomis

Reziumė

Pateikti neardomųjų ultragarsinių tyrimų antrinėmis paviršinėmis išilginėmis bangomis (PIB II) rezultatai. Atlikta realiųjų PIB signalų, generuojamų ir priimtų kampiniais keitikliais, analizė, iširtos pašalinių trikdžių priežastys, pasiūlytos kampinių keitiklių optimalios konstrukcijos. Įvertinti realiųjų kampinių keitiklių parametrai ir PIB II signalų atspindėtų nuo dirbtinių defektų duraliuminio bandiniuose, lygiai. Eksperimentiniais tyrimais nustatyta, kad PIB II signalų amplitudžių santykis su pašalinių trikdžių lygiu yra 24 dB. Tai leidžia gana patikimai vykdyti plonasienių gaminių vidinių paviršių neardomuosius bandymus antrinėmis paviršinėmis išilginėmis bangomis.

Pateikta spaudai 2005 02 25

DOI: 10.5755/j01.u.54.1.16919