

Operating actuator systems of solid optic devices

A. Panich, G. Zhitomirsky

Rostov State university, the Faculty of High Production Processes, SDTD "Piezopribor",

E-mail: piezo@rsu.ru

Introduction

For effective solution of scientific and applied technologies, emerging when observing cosmic objects, it is necessary to provide the aim maximum illumination intensity at laser detection and the opportunity to obtain detailed image of cosmic objects with maximum resolution as well as to realize a maximum high sensitivity of the "telescope – photodetector" system.

When realizing the conditions pointed, there is a natural external noise – the atmosphere turbulence, which along with the absorption of radiation, distorts the wave-front as one, both received from the cosmic radiation object and from the one, radiated by laser transmitters, when detecting and ranging cosmic objects.

For compensation of optic signal wave-front atmospheric distortions in the real time, adaptive optic systems are used. The adaptive optic system operating device is an optic radiation wave-front modulator. One of the wave-front modulator modification is a deformable mirror, which is excited by solid electromechanical transducers, either piezoelectric or electrostrictive ones.

Design and applications

Further, some deformable mirrors, developed in SDTD "Piezopribor" at Rostov State university, are described. Two of them are created on the basis of electromechanical transducers with a cruciform cross-section. Some modifications of the cruciform transducer were applied before in scanning tunnel microscopes. The high sensitivity of the transducer permitted to obtain atomic resolution of the surface [1,2,3].

The construction and diagram of electric connections of the wave-front phase modulator [4] is depicted in Fig.1. The phase modulator contains the deformable mirror 1, a rigid base 2 and a set of piezoelectric elements 3, placed between them. The basis of piezoelectric elements 3 is a monolithic piezoelectric ceramic bar with a cruciform cross-section. The control electrodes 4, connected with the control voltage source 5, are applied to the basic bar surfaces.

A cruciform shape of the cross-section permits to create a high electric field strength in the piezoelectric element, and because of the lateral piezoelectric effect, to obtain a high piezoelectric strain of the bar. Simultaneously, a cruciform shape of the cross-section provides its high rigidity. The same is provided with a trapezoid shape of the cross-section, which gives the bar the qualities of the beam, equal to the bending strength. Mutually perpendicular position of the adjacent piezoelectric elements increases the total rigidity of the

device construction still more, forming a rigid box-shaped structure. The result of the high rigidity is the phase modulator natural resonant frequency and, therefore, a wide operating frequency range.

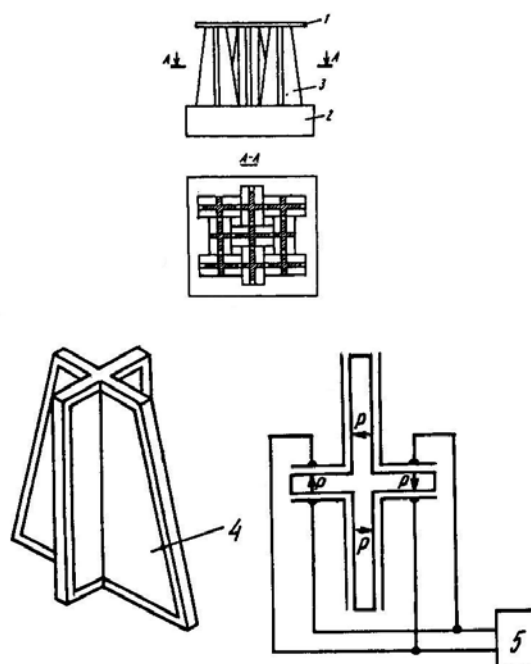

Fig.1. The construction and diagram of electric connections of the wave-front phase modulator: 1 – mirror; 2 – rigid base; 3 – piezoelectric elements; 4 – control electrodes; 5 – control voltage

High values of the mirror deformation permit to correct effectively the phase distortions of the optic infra-red ray.

The phase modulator structure, depicted in Fig.2, permits to eliminate the shape distortions of the operating surface as a result of piezoelectric ceramics ageing with the long operation of the device [5]. The modulator given also contains a deformable mirror 1, a rigid base 2 and a set of piezoelectric elements 3, placed between them. The piezoelectric element 3 is a bar, having a cruciform cross-section.

Two pairs of electrodes 4 and 5, separated by the gap 6, are applied to the lateral surfaces of each bar plate.

In Fig.2, the electrodes 4.1 and 5.1 of one of the piezoelectric element 3 plates are shown. The electrode pairs of four plates of each piezoelectric element 3 are connected in parallel. Piezoelectric elements 3 are connected to the control voltage supply 8.

The piezoelectric ceramic material between electrodes 4 and between electrodes 5 is polarized along the plate thickness. The piezoelectric ceramics in gap 6 between the electrode pairs is polarized along the plate length.

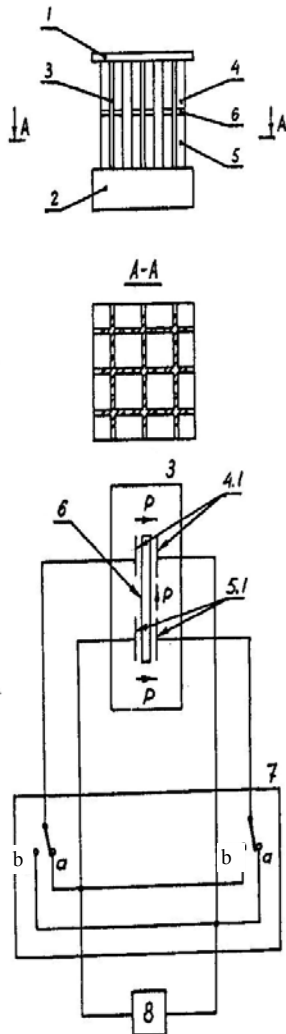

Fig.2. Construction phase modulator: 1 – mirror; 2 – rigid base; 3 – piezoelectric elements; 4, 5 – electrodes; 6 – gap; 7 – switch; 8 – control voltage

When polarizing piezoelectric ceramics, the diagram, analogous to the diagram in Fig.2, in which the control voltage supply 8 is substituted by the polarizing voltage supply, is applied.

In “a” position of the switch 7, when the control voltage supply 8 is applied to the electrodes 4 and 5, there is a longitudinal strain of the piezoelectric element 3, namely, the reduction of its length in the direction of the bar longitudinal axis, that causes a flexural strain of the mirror 1, and as a result, the wave-front phase change of the optic ray, reflected from the mirror 1.

In “b” position of switch 7, voltage from the supply 8 causes the longitudinal strain of the piezoelectric element 3, that is, its lengthening in the direction of the longitudinal axis, as a result of the longitudinal piezoelectric effect in the gap 6. The result of this is a mirror deformation in the direction, opposite to the deformation in the first regime,

that allows to restore the original shape of the operating surface of the mirror 1.

The modulator type given, allows to increase significantly the adaptive optic system operation reliability by means of the considerable increase of time between failures. The greatest effect can be achieved in the Spacecraft high-detailed image production system.

In the next wave-front phase modulator structure [6], between the deformable mirror 1 and the rigid base 2, there is a multilayer unit 3, made of ferroelectric ceramics with a blurred phase transition (Fig.3, a and b). The unit 3 is electrically divided into N sections (into 3 section in the given example: 4, 5, 6). The quantity of layers in the section equals to 2^k , where k is the section number. To the opposite sides of the each layer, the sets of the common and address electrodes 7, 8, 9, 10 are applied. The electrodes are provided with protuberances 11.

The address electrode protuberances are turned with respect to the common electrodes 7 by the angle

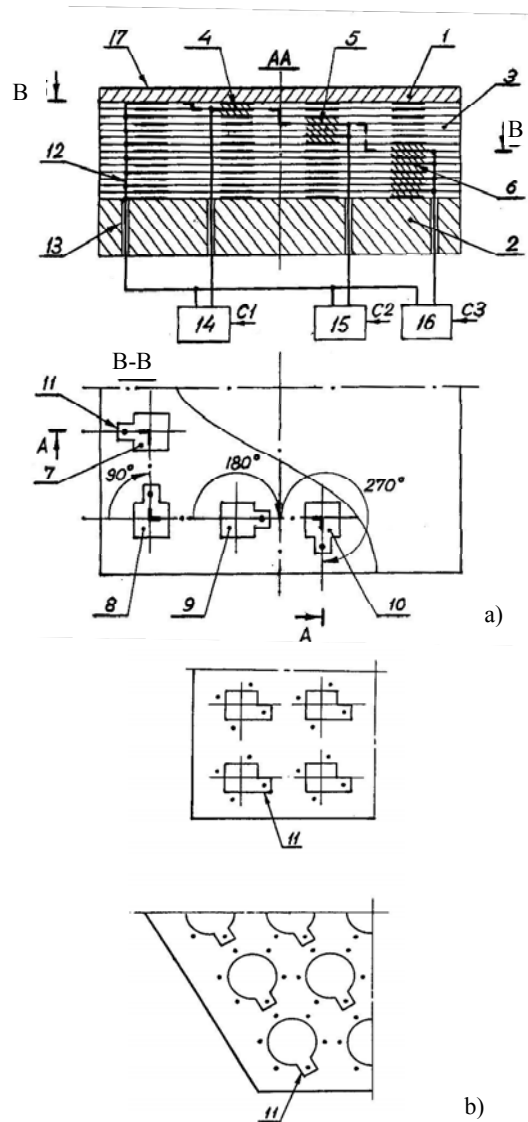

Fig.3. Wave-front phase modulator: 1 – mirror; 2 – rigid base; 3 – multilayer unit; 4, 5, 6 – sections; 7, 8, 9, 10 – address electrodes; 11 – protuberances; 12 – conductors; 13 – holes; 14, 15, 16 – digital electronics switch

$\alpha=2\pi k/(N+1)$. In the given example the angles of rotation are 90° , 180° , 270° .

The electrodes of each section, corresponding to the same address, are connected electrically in parallel by means of conductors 12, passing through the holes 13 in base 2, and through the holes in the electrode protuberances, and connected to the outlet of the respective digital electronic switch 14, 15, 16. The control electronic switch outlets are connected to the control system output register.

In Fig. 3, b the device modifications with three of five sections and different electrode shape are depicted.

Conclusions

The characteristic properties of the modulator type given, are obtained due to of the longitudinal electrostrictive effect in multilayer unit 3 and application of the digital control method. The selection of the material increases the device reliability significantly at the expense of no-ageing and rather low coefficient of linear expansion of the electrostrictive material - lead magniobate – titanate solid solution. Digital control provides low power consumption, that permits to use the device in spacecraft optic systems.

References

1. Adamchuk V. K., Yermakov A. V., Lyubinetsky I. V., Zhitomirsky G. A., Panich A. E. Devices and trial-and-error method. 1989. №5. P.182-184.
2. Patent RF № 2114493. Cl. H01L41/08,1998. Operating device of scanning microscope. Zhitomirsky G. A., Panich A. E.
3. Helfrich J. A., Adenwalla S., Ketterson J. B., Zhitomirsky G. A. Character of piezoceramic crosses... Rev. Sci. Instrum. 66(10), October 1995.
4. Patent RF № 2080638. Кл G02F1/00, 1997. Phase wave-front modulator. Zhitomirsky G. A., Panich A. E.
5. Patent RF № 2202816. Кл G02F1/00, 2003. Phase wave-front modulator. Zhitomirsky G. A., Panich A. E.
6. Patent RF № 22231099. Кл G02F1/05, 2004. Solid wave-front modulator. Panich A. E., Zhitomirsky G. A.

A. Panich, G. Zhitomirsky

Kietų kūnų vykdikliai adaptyviosiose optinėse sistemose

Reziumė

Nagrinėjamos originalios, deformuojamą veidrodį turinčios konstrukcijos, skirtos optinių signalų bangos fronto atmosferiniam iškraipymui kompensuoti. Aprašomas banginio fronto modulatorius kaip deformuojamas veidrodis, kuris funkcionuoja naudojant kieto kūno elektromechaninį keitiklį (pjezokeramiką). Tokio tipo modulatorius adaptyviosiose optinėse sistemose įgalina naudoti skaitmeninį valdymą, kas sutaupo energetinius išteklius ir padidina visos sistemos patikimumą.

Pateikta spaudai 2005 03 02

DOI: 10.5755/j01.u.54.1.16923