

Diagnostics of multi-layer cylindrical structures based on wave's interference

V. Volkovas, V. Sukackas

Kaunas University of Technology

Technological Systems Diagnostics Institute

Introduction

A layer of the sediment forms and firmly sticks to the wall of different cylindrical structures, for example, on pipe-lines during the operation in chemical, oil-processing industries and in power plants. The layer makes technical performance of devices considerably worse. Thus, diagnostics of technical state of pipes is an important problem. Diagnostics of the condition of internal cavity of pipes should answer the following questions:

- a) is the pipe empty;
- b) if not, what is at the internal walls: liquid or solid;
- c) if there is a solid layer, what is the thickness of it.

Non-destructive testing and measurement of the thickness of a sediment layer is a high priority aspect of the above mentioned problem.

In this case well-known ultrasonic, impulse and resonance methods of thickness measurements are non-efficient. As a rule, the surface of a sediment layer is non-uniform and porous thus hindering a sufficient reflection of ultrasonic waves necessary for the functioning of the thickness measuring instruments. The sediment is non-homogeneous and is notable for the absorption and scattering of ultrasonic waves. In addition, conventional measuring instruments can merely measure the local thickness. In our case it would be necessary to make a number of measurements of the same diameter of the pipe. It is very promising to develop a method that would enable us to measure some generalized thickness of a sediment. We suggested new principles of diagnostics that can answer these questions and enable development of original measuring instruments and indicators for sediment layer thickness and liquid level sensors in pipelines. One integral value of the measured unit in one cross-section of the pipe is enough for these instruments. Therefore, measurements in a number of cross-section points are not necessary and measuring effectiveness is considerably increased.

For obtaining the integral value it is purposeful to use waves of the same order or longer than wall thickness and longer than the measured sediment thickness. We used anti-symmetric Lamb's waves of the zero order

1. Waves propagating within the cylindrical structure and interference phenomenon

Among variety of cylindrical structures there are the pipe-lines for which $d \ll R$, where: d is the thickness of the wall, R is the average radius of the wall.

The segment of the wall (Fig. 1) slightly differs from the plate with the thickness d when symmetrical and asymmetrical Lamb waves are easily excited:

$$U_{sz} = A \cdot F_s(m_s, \omega, z, d) \cdot \sin(k_s z - \omega t), \quad (1)$$

$$U_{az} = A - F_a(m_a, \omega, z, d) \cdot \sin(k_a x - \omega t), \quad (2)$$

where: U_{sz} and U_{az} are the displacements of the elements of the wall in the direction of the axis z ; A and B are the constants; F_s is the even function with respect to z ; F_a is the odd function; m_s and m_a are the order of the wave (0, 1, 2, ...), ω is the frequency; k_s and k_a are the numbers of the wave.

The coordinate system is shown in Fig. 1. It is characteristic of the functions F_s and F_a that their values are not equal to "0" in the surfaces of the wall when $z = d/2$. The latter circumstance is very important in our case, when a layer of the sediment is formed and it firmly sticks to the wall. The waves excite displacements also in the direction of axis x , that will not be taken into account when considering the excitation and the reception of the waves we use.

Without any restriction, i.e. for any d there exist and, therefore, can be easily excited only the Lamb waves of the lowest order: the symmetrical U_{sz} and asymmetrical U_{az} , when $m_s = m_a = 0$, the above mentioned waves differ in the distribution of displacements. They are symmetrically distributed in the wave U_{sz} with respect to the plane $z = 0$ and when $d \rightarrow 0$, this wave becomes longitudinal. On the contrary, the displacement (of one sign) in the thickness of the plate is characteristic of the wave U_{az} , when $d \rightarrow 0$, it becomes flexural.

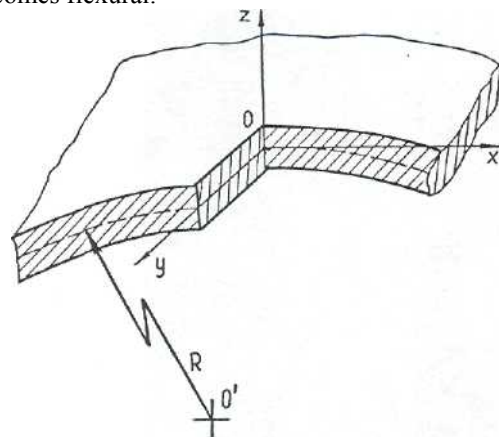

Fig. 1. The segment of the wall of the pipe

Both waves differ in absolute values of the wave velocity and in the dispersion dependence on the frequency. The velocity of the waves has been measured by two methods: interferometric and impulse.

One of the transducers is excited by the alternating voltage while measuring with the interferometry method. The longitudinal waves propagate along the wall and are

transformed into the Lamb waves spreading in all directions (in the plane $z = 0$, Fig. 1). Standing waves are formed in the wall, if the phases of the sending signal and the signal propagating a round the wall in both directions coincide. These waves interfere and are registered by another transducer-receiver (Fig.2).

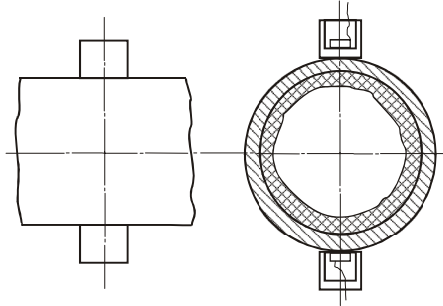

Fig. 2. Positions of the transducer

Every time such resonances are repeated, when

$$2\pi R = n \cdot \lambda \quad (3)$$

where $\lambda = c/f$ is the wave Length; c is the speed; n is the number of waves in the wall (a number of resonances). Using the formula (3) for both cases, when numbers of the waves in the wall are n and $n + \Delta n$ and the frequencies are f_1 and f_2 , we have:

$$c = \frac{(f_2 - f_1) \cdot 2\pi R}{\Delta n} \quad (4)$$

From the general theory of interferometer follows [1], that when a wave propagates in one direction and a reflected wave propagates in the opposite one, standing waves occur, when the total number of semi waves in the acoustical path is $n \cdot \lambda/2$. Our case differs in a twice smaller number of resonances. The -frequency response of an empty pipe ($R=75$ mm, $d = 8$ mm) was obtained changing the frequency within the limits of 60-200 KHz. The above mentioned characteristics are eliminated by using different pairs of wide-band transducers. Therefore, the amplitudes values slightly differ. One can see that a certain type of waves really exists. To increase reliability of measurements an impulse method was applied for the control measurement of velocity. Measuring the value of velocity, the following type of waves was determined: longitudinal or flexural [2, 4].

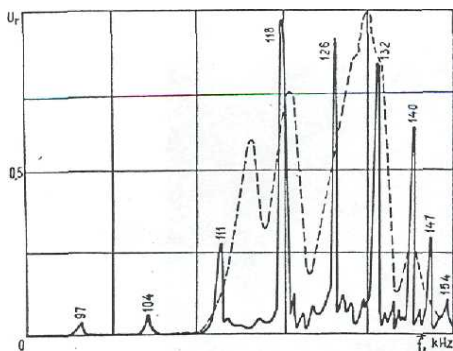

Fig. 3. The frequency responses: an empty pipe $R=75$ mm, $d=8$ mm (straight line) and the same pipe with a layer of the sediment of 1,5-2 cm (dotted line); numbers - resonance frequencies in kHz

Investigation [3, 4] shows that the asymmetrical Lamb wave of the lowest order propagates in an empty wall and another wave that can be excited is symmetrical of the lowest order and differs very much in the character of speed values and dispersion. Waves of the higher orders are not excited below the critical values of $d \cdot f$.

The frequency response of an empty steel pipe is shown in Fig.3 (straight line). Its exterior radius is $R = 76$ mm, the thickness of the wall is $d = 8$ mm. The resonance frequency that is rounded to kHz is marked by the resonance upper parts. It is obtained by comparatively narrow-band transducers. The measurements were carried out using wide-band non-resonance transducers, with the above mentioned pipes and also different pipes, their radius being $R = 25$ mm and $d=3.5$ mm.

2. Discussion of the results

The measurements were carried out when the parameter $f \cdot d = (40-160)$ kHz·cm. The values of the speed (m/s) and the character of dispersion, (considerable increase of the speed), while increasing " $f \cdot d$ " (f is frequency), especially at $f \cdot d = 150$ kHz cm, show that the asymmetrical Lamb wave of the lowest order is excited in the wall. The frequency response of the pipe having a 1.5-2.0 cm layer of sediment is marked by the dotted line (Fig.3). The pipe has been used for oil-refining at high temperatures. One can see that the interference is considerably reduced. Experiments have shown that the interference is also reduced by the liquid that is in a pipe and this fact must be taken into consideration.

This reduction interferes with the use of the interferometric method of velocity measurement. While using the impulse method for the pipe, its radius being $R=25$ mm and $d=3.5$ mm, it is proved that, when a layer of sediment changes within the limits of 0 – 10 mm, the velocity of waves changes not more than 10%. It allows drawing a conclusion that another type of waves do not occur. If they occurred, the difference among the speeds would be greater because the expected velocities of waves in sediment are at least twice less than in steel. We managed to evaluate only the velocity of longitudinal waves in sediment, when is 2700 m/s. Therefore, the sediment plays an effective role of a damper. It allows expecting a great sensitivity of the method with negligible thickness. On the contrary, with greater thickness we expect lower sensitivity. The experiment showed that due to the attached mass layer of liquid or solid having an acoustic contact with the internal surface of the pipe changes the velocity of waves and increases their absorption. Each of these effects was applied in different fields [5].

Correlation between the condition of the pipe and characteristics of interference is another important question in investigation of the problem. It is possible for different thickness of the sediment in the pipe to carry out the measurement of the parameters of interference. But for that case we must to develop a method that would enable us to determine diagnostic parameters which are reliable enough. We apply the autocorrelation function of the frequency response, which is measured using the transducer-receiver configuration (Fig.2). The

autocorrelation function easy shows the differences – maximum steepness of that function in the internal units its first local trough is strictly related to the attenuation of waves in the wall of resonance pipe (see Fig.4).

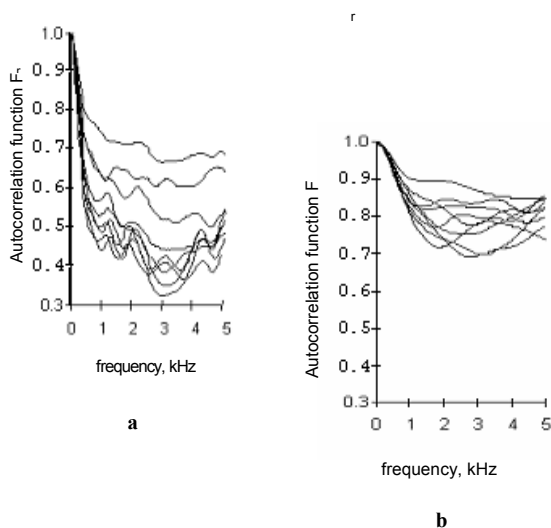

Fig.4. Starting points of the autocorrelation functions F_r of frequency response; pipe and cases are the following: steel pipe, $r=74$ mm, wall thickness $t=8$ mm; a - without sediment, with rust layer, b - with 10 mm carbon sediment layer. In each case 10 measurements were performed in the same cross-section by removing and remounting transducers

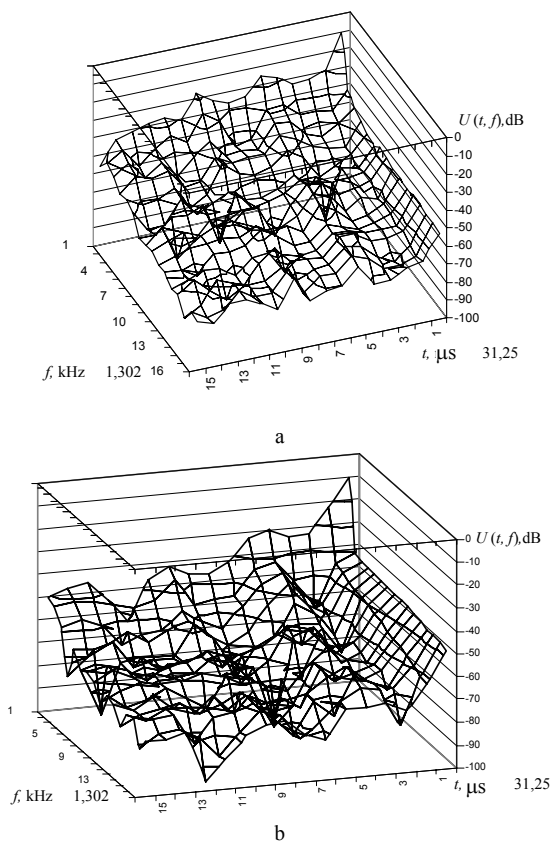

Fig.5. 2D Fourier transform of the envelope functions of the received pulse $u=u(f, t)$; pipe and cases are the following: steel pipe, $r=74$ mm, wall thickness $t=8$ mm; a - without sediment, b - with 20 mm carbon sediment layer

Investigation [6] showed that the envelope function of the received pulse $u = u(f, t)$ depends on a sediment's layer. We apply 2D FFT for analysis of that function (see Fig.5).

The results show that decrease of the velocity of peaks of the mapped signals is the measure of wave absorption in the pipe's wall and can be characteristics of sediment's value inside the pipe. Using this method, the measurement time decreases, in comparison with the correlation method.

Conclusions

The mechanism of the mentioned phenomenon is not completely clear and investigations are being continued. The dispersion of the velocity is chaotically scattered in the way of waves, when the layer of sediment is not thick enough. This fact appears because of the unevenness of the total sum thickness. A portable indicator of sediment is being developed [3]. It operates according to the method described above. The transducer is excited by the voltage and the frequency is modulated according to the "triangle" law within the limits of 110-150 kHz.

The ratio of the maximum of the received signal and its average value are approximately proportional to the quality factor of the system and changes from tens in an empty pipe to ones in a pipe with some sediment. That was the main information about the processing algorithm in the device.

The correlation function has characteristic dependence that allows development of new measuring instruments for estimation of sediment layer thickness.

The described interference method may be developed using another processing method of the frequency response, e.g., 2D FFT.

References

1. **Ilgūnas V., Jaronis E., Sukackas V.** Ultrazvukoviye interferometri. Mokslas, Vilnius. 1983.
2. **Vibornov B. I.** Ultrazvukovaya defektoskopiya. Metalurgiya. Moskva. 1985.
3. **Volkovas V., Sukackas V., Potapenko V.** IP567 Patent of Lithuanian Republic, Inven. buil. Nr.12. 1994.
4. **Volkovas V., Sukackas V.** An interferometric method of evaluating engineering pipeline state. Russian Journal of Nondestructive Testing. ISSN 1061-8309. Kluwer Academic/Plenum Publishers. 1995. Vol.31. No.8. P.604-607.
5. **Sukackas V., Volkovas V.** Investigation of the Lamb wave inference in a pipeline with sediments on the inner surface. Russian Journal of Nondestructive Testing. ISSN 1061-8309. Kluwer Academic/Plenum Publishers. 2003. Vol.39. No.6. P.445-452.
6. **Sukackas V.** Evolution of the received pulse exciting a circular resonator by bursts. Kaunas: Technologija. Ultragarsas. 2004. No.4(53). P.37-39.

V. Volkovas, V. Sukackas

Daugiasluksnių cilindrinų struktūrų diagnostika bangų interferencija

Reziumė

Nagrinėjamas asimetrinių Lembo bangų interferencijos mechanizmas ir reiškinių ypatumai, priklausantys nuo daugiasluksnės cilindrinės struktūros būsenos. Parodyta, kad cilindrinės struktūros būseną, apibūdinamą technologinių procesų metu jos viduje susidariusių nuosėdų sluoksniais, galima kontroliuoti analizuojant struktūros amplitudės dažninę funkciją. Tam siūloma naudoti vidurkinimo, koreliacinių funkcijų bei Furjė metodus.

Pateikta spaudai 2005 04 29

DOI: 10.5755/j01.u.55.2.16926