

Design of a low noise preamplifier for ultrasonic transducer

L. Svilainis V. Dumbrava

Signal processing department, Kaunas University of technology,

Studentu str. 50, LT-51368 Kaunas, Lithuania, tel. +370 37 300532, E-mail.:svilnis@ktu.lt

Introduction

Development of air-coupled ultrasonics is raising demands for electronics used. Because of large difference of acoustic impedances of solid body under investigation and air, testing signal is attenuated. Attenuation can reach up to 100dB, so powerful transmitters and low noise receivers should be used. Since a conventional ultrasound equipment [1] is not suitable in this case, development of dedicated equipment is on its way. Among high power excitation techniques, users are trying to squeeze out better parameters from the transducer preamplifier [2, 3].

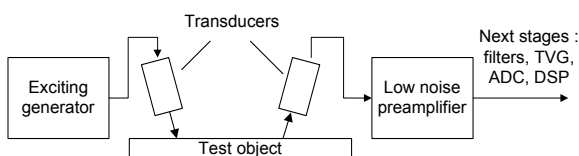

Fig. 1. Air-coupled ultrasonic NDE system setup

The ultrasonic transducer is excited by an electrical pulse and transmits the ultrasonic pulse into air and only then a signal is entering the medium under investigation. The ultrasonic pulse travels in the material and is emitting some energy into air. This energy is picked up by a receiving air-coupled transducer.

In this paper we concentrate on the receiving transducer and the preamplifier in order to obtain the best signal to noise performance.

Possible solutions

A few possible solutions for performance optimization are available:

- Simplest approach would be to use the amplifier with lowest noise components specified by a manufacturer. If an operational amplifier is used, the corresponding datasheet will indicate the voltage and current noise spectral densities e_n and i_n . Minimizing those two seems to be sufficient to reach the best noise performance. As it can be seen from further investigation, this approach is not giving a unique solution – what is good for one type of ultrasonic transducer might be of little or no use for other.
- Maximize a signal level, by increasing the amplifier input impedance, so the signal generated by the transducer is not dampened. Another way is to apply matching circuits [4, 5], so the signal cable or the transducer impedance is best matched for minimum reflections of band flatness. But this requirement usually calls for a high input

impedance, which is expected to generate more noise. Also the noise level is left unaccounted here.

- Minimize the preamplifier output noise, taking into account all possible noise sources influences [2]. However, there is a need to separate the sources of noise which can not be modified or which would degrade the signal performance.
- Minimize the noise figure. The noise figure is expressing the signal-to-noise ratio degradation while signal is passing the amplifier electronics. Again, as can be seen from a further investigation, this method also has some shorts coming like signal source noise increase is reflected as the noise figure improvement.
- The complex approach. Since we are speaking about the measurement, major importance is the signal-to-noise ratio (SNR), because SNR is influencing the measurement errors. Simple to say, it still requires some techniques to be developed. Namely, as with methods above, we need some expression of the signal level and how it is influenced by a circuit parameters. Also, a noise behavioural model needs to be developed. Both should be combined in order to give a single result.

Noise model

The noise model can be developed either into analytical form [4] or be modelled using some circuit oriented software like PSPICE [6]. Despite that the PSPICE modelling seems to offer the easiest and closer to reality approach, we decided to use the analytical model, since in such a case noise contributors can be analyzed separately, cutting out the sources level of which can not be modified or controlled. For this purpose we have developed the analytical noise model, incorporating both transducer and electronics units [7].

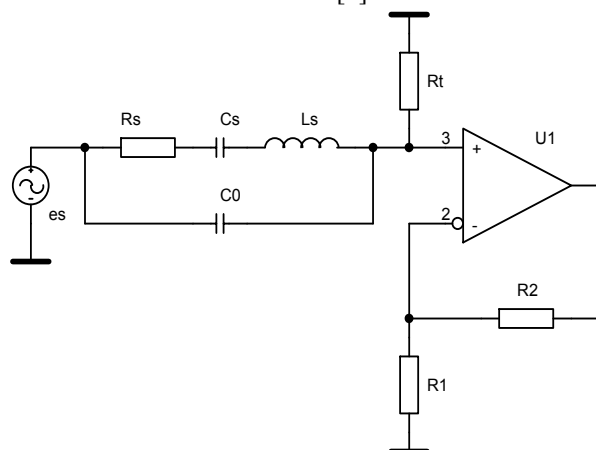

Fig. 2. Electrical equivalent of the circuit noise to be modeled

The noise spectral density of the is input resistance R_t

$$e_T^2 = 4kTR_t; \quad (1)$$

where $k=1.380658 \cdot 10^{-23}$ [J/C] - Boltzmann constant, T is the absolute ambient temperature.

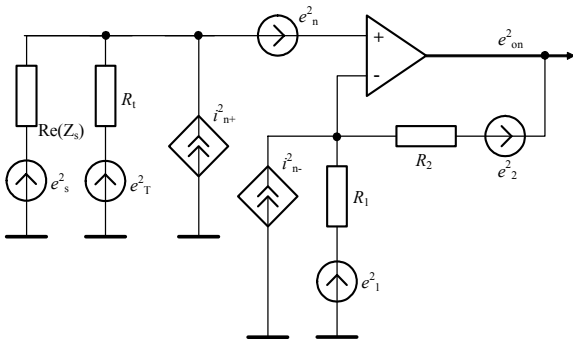

Fig. 3. Noise model circuit

The transducer noise spectral density is determined by the real part of the transducer impedance [4]

$$e_s^2 = 4kT Re(Z_s). \quad (2)$$

The feedback circuit resistors contribute the noise densities

$$e_1^2 = 4kTR_1; \quad e_2^2 = 4kTR_2. \quad (3)$$

With the amplifier noise gain

$$G = \frac{R_1 + R_2}{R_1} \quad (4)$$

we get the equation for the output noise density calculation:

$$e_{tot}^2 = G^2 \left| \frac{R_t}{R_t + Z_s} \right|^2 e_s^2 + G^2 \left| \frac{Z_s}{R_t + Z_s} \right|^2 e_T^2 + G^2 \left| \frac{R_t Z_s}{R_t + Z_s} \right|^2 i_{n+}^2 + G^2 e_n^2 + (G - 1)^2 e_1^2 + e_2^2 + R_2^2 i_{n-}^2. \quad (5)$$

Signal propagation model

To simplify the development of the signal model, we subdivide the task into two possible applications:

- narrowband inspection, when continuous in time (CW) or close to (CW burst) signals are used (e.g. for attenuation measurement);
- wideband inspection, when signals used occupy some definable bandwidth (e.g. pulsed signals).

The transducer signal depends on various factors, like transmitting and receiving transducer matching to air, test object coupling to air, transducers orientation, object defects interaction with signals etc. In order to take at least close approach to the factors mentioned, complexity of the model is increasing [5, 6]. There have been attempts to simplify such a solution, with quite useful results [8].

We are taking a different approach. In this paper we will concentrate on a narrowband inspection analysis, so signal is close to the operating frequency and the voltage source internal impedance is determined by R_s . In such a case the signal propagation through amplifier circuits is calculated as

$$e_{sig}^2 = K^2 \left(\frac{R_t}{R_t + R_s} \right)^2 e_{tr}^2 \quad (6)$$

where e_{tr} is the transducer signal internal voltage source. Even further, since we are interested on *how* amplifier circuit elements are influencing the signal level, we do not need an absolute value of the signal received. We just need to have some sort of indication how the signal level will change with circuit parameters. So, we will be investigating the signal level change, regarding the maximum signal level achievable. Since best propagation is achieved when R_t is infinity, Eq.6 becomes

$$SF^2 = \frac{e_{sig}^2}{\max(e_{sig}^2)} = \left(\frac{R_t}{R_t + R_s} \right)^2; \quad (7)$$

where SF denotes the normalized signal.

Signal propagation analysis

In order to start analysis of signal propagation, we have investigated various air coupled transducers [2, 5, 9] in order to evaluate the range of transducer parameters. In order to restrict ourselves we have concentrated on (400-800) kHz frequency range transducers, because of popularity of this range. Results of investigation are presented in Table 1.

Table 1. Air coupled transducers parameters

Transducer	R_s , [kΩ]	C_s , [pF]	L_s , [μH]	C_0 , [pF]
Tr 1	9,3	1758	88,7	3333
Tr 2	410	173	561	480
Tr 3	1800	26	1600	65

By analyzing the data presented in Table 1, one can see that R_s range is within 10Ω to few kΩ. Therefore we have chosen such a range in the signal propagation analysis. Results of application of Eq.7 for resistance range mentioned are presented in Fig. 4.

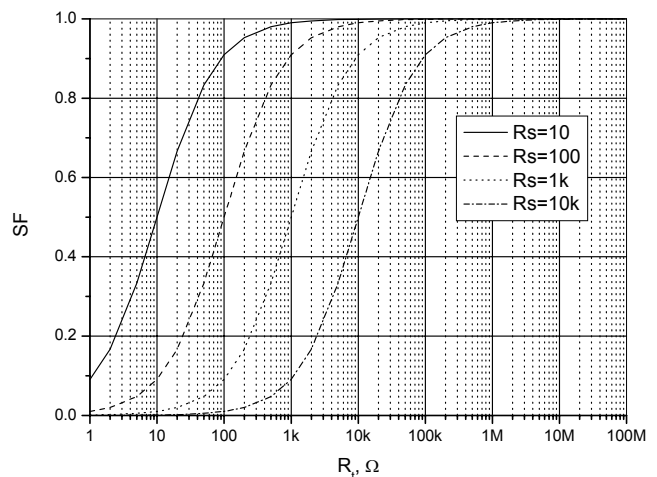

Fig. 4. Normalized signal propagation vs. input resistance R_t and transducer R_s .

It can be seen that the ratio of input resistance R_t and the transducer impedance R_s should be above 10 times in order to have lowest signal attenuation (the highest SF).

Noise analysis

In order to evaluate the importance and influence of circuit parameters, we now investigate Eq.5 components. The operational amplifier internal noise voltage source e_n is of major interest. As mentioned above, the simplest approach would be to minimize this parameter, by choosing an appropriate amplifier. In addition to that, this member has the simplest expression. We have chosen three amplifiers as representatives of achievable limits. One (LMH6624) is presenting the lowest voltage noise, an other (OPA657) is exhibiting the lowest current noise source and the third one (CLC425) has both current and voltage noise in between the first two candidates. The parameters are presented in Table 2.

We start analysis using those parameters which do not interfere with other components of noise generation. Since the feedback circuit is not influencing the input components (the transducer and the input resistor) noise, we analyse these components first of all. In order to be able to neglect the R_1 and R_2 noise, their voltage spectral density has to be 1/3 (less than 5%) of that of contributed by e_n . Let us solve Eq.5 components for this requirement. The maximum R_1 value for R_1 thermal noise exclusion is calculates as

$$e_1^2 = \frac{G^2 e_n^2}{3^2} \Rightarrow R_{1max} = \frac{G^2 e_n^2}{3^2 4kT(G-1)^2} \quad (8)$$

The maximum R_1 value for R_2 thermal noise exclusion is

$$e_2^2 = \frac{G^2 e_n^2}{3^2} \Rightarrow R_{1max} = \frac{G^2 e_n^2}{3^2 4kT(G-1)} \quad (9)$$

The maximum R_1 value for exclusion of the amplifier current noise i_n generated voltage when loaded by R_1 and R_2 parallel connection is

$$R_2^2 i_n^2 = \frac{G^2 e_n^2}{3^2} \Rightarrow R_{1max} = \frac{G e_n}{3 i_n (G-1)} \quad (10)$$

It can be proved that the reasonable gain value to use in calculations is about 100. The results obtained for this gain level will hold true for all gain values in the range from 2 to 200. The calculations results, basing all the assumptions and Eq.8, 9 and 10 are presented in Table 2. The last two columns summarize the values recommended for R_1 and R_2 . In order to suit all amplifiers, in subsequent calculations we will be using the lowest values – $R_1=10\Omega$, $R_2=1k\Omega$.

Table 2. Amplifier parameters and corresponding limit and recommended values for R_1 and R_2 at $G=100$

Amplifier	e_n , nV/ \sqrt{Hz}	i_n , fA/ \sqrt{Hz}	R_{1max} (9), Ω	R_{1max} (10), Ω	R_{1max} (11), Ω	R_1 , Ω	R_2 , k Ω
LMH6624	0.95	2300	10	610	140	10	1
OPA657	4.8	1.3	160	15610	1243200	160	15
CLC425	2	800	30	2710	840	30	2.7

The next candidate for analysis should be the component which we can not be modified, e.g. transducer. Only transducer noise spectral density component e_{ntrtot}^2 at

the amplifier output with the gain 100 is presented in Fig .5. In order to reduce the complexity, the input resistance R_i is taken to be close to infinity.

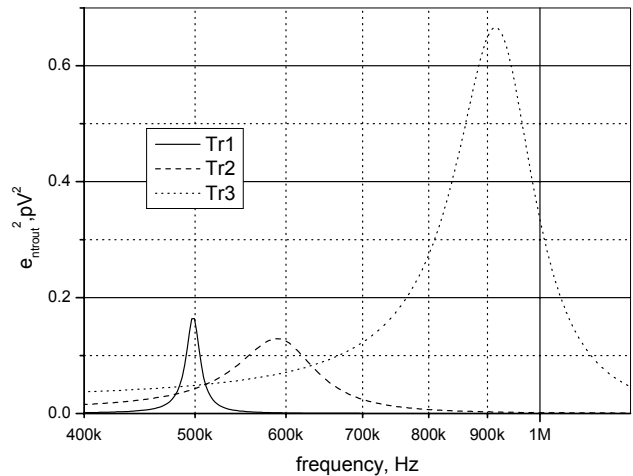

Fig. 5. Transducers noise spectral density at the amplifier output

The output noise can be calculated by integrating component e_{ntrtot}^2 over a frequency range. One can see that noise is large at the transducer resonant frequency and is degrading by going apart. For the sake of simplicity, we take the integral over the wide frequency range 150 kHz to 2.5MHz, so there is no need for taking into account an individual transducer bandwidth. The value obtained represents the noise RMS value at the amplifier output:

$$E_{esRMS} = \sqrt{\int_{f_1}^{f_2} e_{ntrtot}^2 df} \quad (11)$$

In such a way we have the ability to analyse noise RMS at the amplifier output behaviour versus the input resistance R_i . The diagrams obtained are presented in Fig.6. In order to be able to judge about the noise influence, the operational amplifier voltage noise source e_n contributed RMS level at the output is added. From the signal propagation analysis it can be seen that the input resistance R_i is desired to be over 10 times of the transducer R_s . Therefore $R_i=10 R_s$ values for best signal performance are indicated for all three transducers.

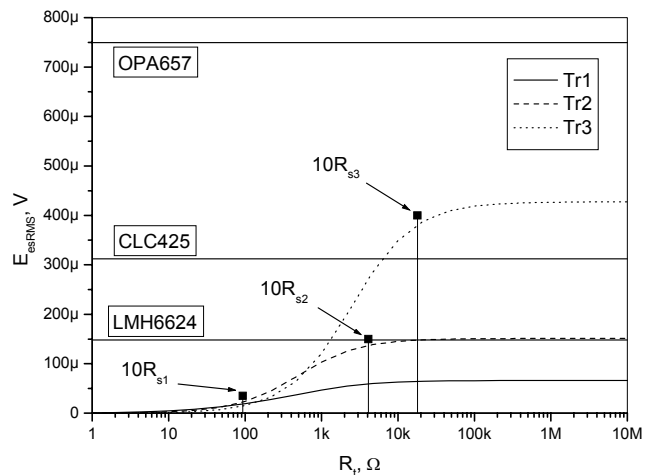

Fig. 6. Transducers noise RMS at amplifier output vs. R_i

One can see that using R_t which is optimal for signal propagation will cause an increase in the output noise level. For Tr1 this increase is insignificant with any amplifier, Tr2 noise will increase by about $\sqrt{2}$ times for the lowest e_n amplifier and will be insignificant with other two. Tr3 noise will increase about 3 times if the lowest e_n amplifier is used or increase 1.7 times if average e_n amplifier is used, but remains almost the same in the case of a relatively large e_n .

In the same way we can calculate the output noise for the resistance R_t thermal noise component e_{nRt} getting the E_{nRtRMS} at the amplifier output (Fig. 7).

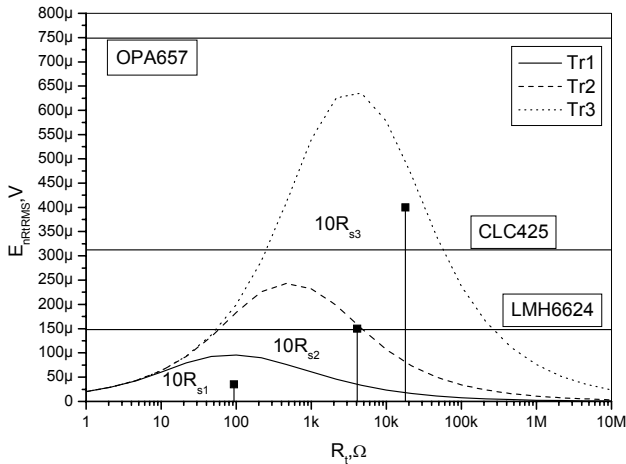

Fig. 7. R_t thermal noise RMS at the amplifier output versus it's value

This time we see that it makes sense to increase the R_t value further above $10R_s$, so the R_t thermal noise component can become negligibly low. This behaviour can be explained by damping of the thermal noise source voltage by a lower impedance of the transducer circuit.

Taking the same integral over the frequency range we calculate the current noise source in the generated voltage contribution to the noise RMS. The E_{in+RMS} voltage at the amplifier output is presented in Fig. 8.

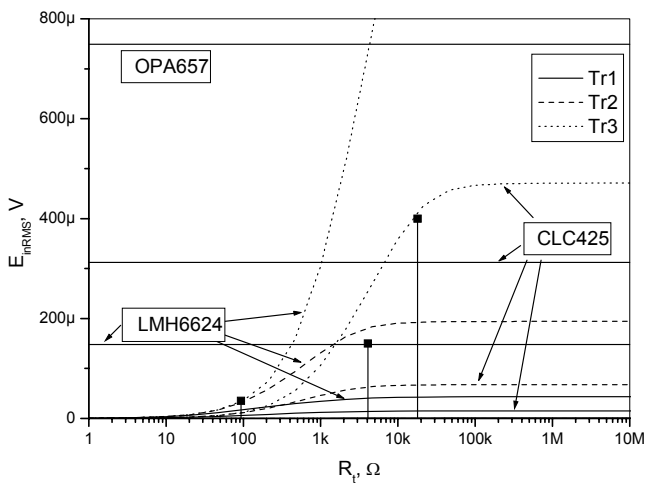

Fig. 8. Current noise source in+ generated output noise RMS versus R_t

It is evident, that the LMH6624 amplifier is not suitable for the transducer Tr3 with high R_s and R_{oe} values.

The E_{in+RMS} value for this combination is extending ten times above the e_n contributed noise level. The same comes to Tr2 and LMH6624 combination, only difference is not that large. Application of the OPA657 amplifier significantly reduces the E_{in+RMS} level – it is lowest part of the drawing, so is not even notable. But it should be noted here that the OPA657 exhibits quite large e_n (5 times that of LMH6624), so this fact should be taken into account when shifting to the OPA657 amplifier.

Finally, we calculate the total amplifier output noise E_{totRMS} . The results are presented in Fig. 9.

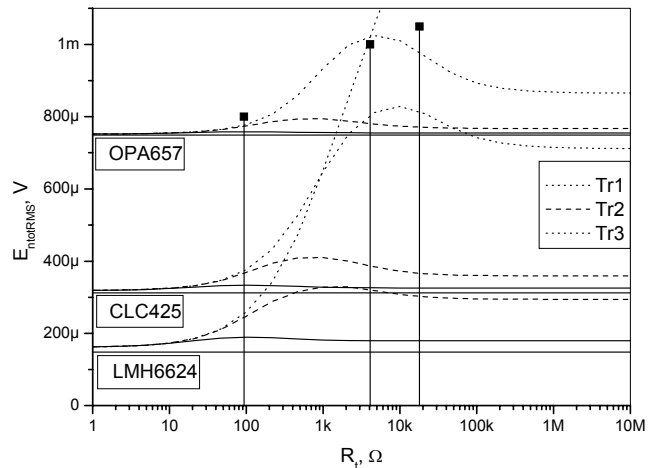

Fig. 9. Total output noise RMS versus R_t

It is clearly visible that major noise contribution is by e_n . But for transducers with large R_s and R_{oe} (Tr2 and Tr3) current noise at the desired values of R_t starts prevailing over e_n . So, basing only noise analysis it can be predicted that transducer Tr3 should be used with OPA657 or with CLC425 – amplifiers with a lower current noise i_{n+} .

SNR analysis

Taking all noise sources into account and calculating the signal level at the output we normalize the value obtained to SNR value at R_t infinity and the lowest R_s transducer operating with the best e_n level amplifier LMH6624. Then the circuit with best noise performance SNR is 0dB. The SNR analysis results are presented in Fig.10.

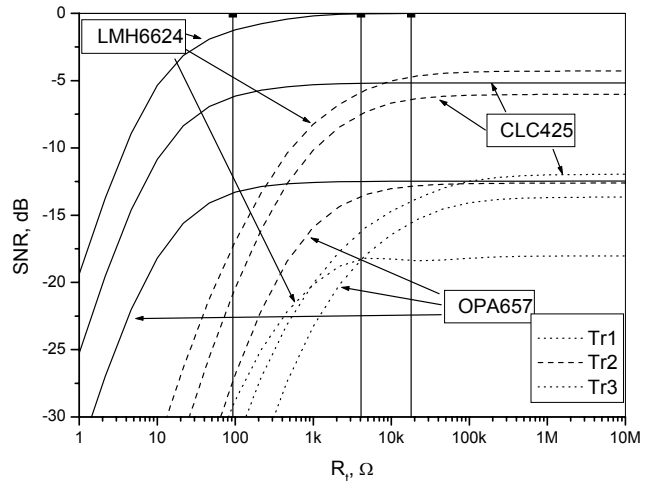

Fig. 10. Normalised SNR change at the amplifier output versus R_t

Analysing the results obtained one can see that lowest e_n amplifier is suitable for a quite large range of transducer R_s values (10Ω to 400Ω – the transducers Tr1 and Tr2). But such e_n does not leave much room for noise reduction the in case of large transducer R_{oe} and R_s (the transducer Tr3). Even further – bias currents of amplifiers investigated were not taken into account, because the resistance at the negative amplifier input is quite low (10Ω) and the positive input DC resistance is high (it is desired to have it above $10k\Omega$), the bias currents skew will cause output DC value out of limits. In literature [1] authors recommend using a low bias current amplifier in such a case (e.g. OPA657). Our solution is different – we break amplifier feedback loop, so the amplifier DC gain gets equal 1. Therefore, the output DC shift due to bias currents skew is low. Taking into account that DC coupling is not needed in ultrasonic applications, the bias shift may be neglected. So, the high bias current amplifier can be used even with a high level of biasing mismatch. As a result of the analysis we present final schematics for the preamplifier (refer to Fig.11). The preamplifier will be used with relatively low impedance transducers [5, 9].

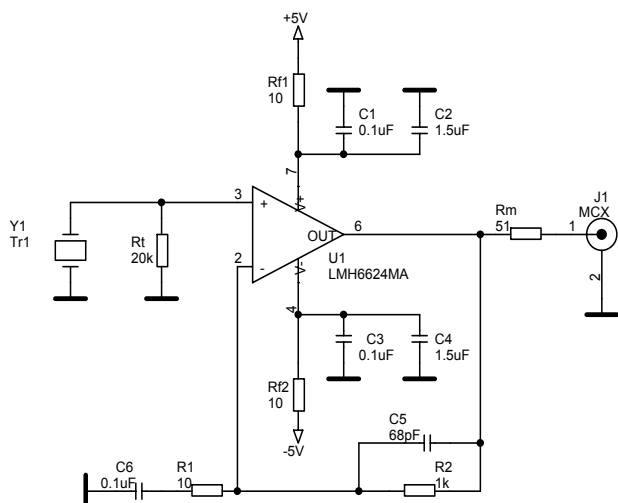

Fig. 11. Final amplifier schematics

Some additional components have been added to schematics to keep the calculated noise performance. The capacitor C_6 in series with R_1 is introducing the high pass filter with the -3 dB cutoff frequency of 150 kHz. The capacitor C_5 will add a low pass filter with the 2.5 MHz cutoff frequency.

Conclusions

Several approaches have been used to improve noise performance of a transducer preamplifier for relatively narrowband signal case. By analysing every noise component it has been shown that e_n has major contribution to a noise level. The noise current source is of next importance. The approach have been demonstrated how i_n - component can be reduced. Unfortunately, i_{n+} component influence is dependant an transducer

parameters, so it can not be completely taken out. For some transducer types, with high R_s or R_{oe} this component starts prevailing over the e_n part. In order to have full noise performance evaluation, the SNR analysis has been used. The final design is best suited for relatively low source impedance transducers. If the amplifier for other type of transducer is needed, the circuit parameters should be adjusted in order to get the best noise performance.

Acknowledgements

We would like to thank the Dr. Darius Kybartas for his consultations and useful literature support.

References

1. Svilainis L., Puodžiūnas V. Ultrasonic NDE system: the hardware concept. Ultragarsas. Kaunas: Technologija. 1998. No.29. P.34-40.
2. Yanez Y., Garcia – Hernandez M. J., Salazar J., Turo A., Chavez J. A. Designing amplifiers with very low output noise for high impedance piezoelectric transducers. NDT&E International. 2005. Vol.38. P. 491-496.
3. Turo A., Salazar J., Chavez J. A., Kichou H. B., Gomez T. E., Montero de Espinoza F., Garcia – Hernandez M. J.. Ultra-low noise front-end electronics for air-coupled ultrasonic non-destructive evaluation. NDT&E International. 2003. Vol.36. P. 93-100.
4. Dumbrava V., Adomaitis K. Modeling of matching ultrasonic transducers. Elektronika ir elektrotechnika . 2002. Vol 41. P.55-59.
5. Kažys R., Vladišauskas A., Žukauskas E. Wideband air – coupled ultrasonic transducers. Ultragarsas. Kaunas: Technologija. 2004. No.52. P.21-28.
6. Maione E., Tortoli P., Lypacewicz G., Nowicki A., Reid J.M. PSpice modelling of ultrasound transducers: comparison of software models to experiment. IEEE transactions on ultrasonics, peroelectrics and frequency control. 1999. Vol.46. P.399-406.
7. Dumbrava V.,Svilainis L. Noise model for ultrasonics transducer preamplifier. Elektronika ir elektrotechnika. Kaunas: Technologija. (submitted for publication).
8. Augutis S. V., Dumčius A., Gailius D., Styra D., Jačėnas S. The ultrasonic method of hardboard testing. Ultragarsas. Kaunas: Technologija. 2004. No.53. P.14-19.
9. Žukauskas E., Cicėnas V., Kažys R. Application of air – coupled ultrasonic technique for sizing of delamination type defect in multilayered materials. Ultragarsas. Kaunas: Technologija. 2005. No.54. P.7-11.

L. Svilainis, V. Dumbrava

Ultragarsinio keitiklio mažatriukšmio pradinio stiprintuvo projektavimas

Reziumė

Pateikta metodika, kaip optimizuoti ultragarsinio keitiklio pradinio stiprintuvo signalo ir triukšmo santykį, remiantis elektroakustinio trakto triukšminiu modeliu. Kiekviena triukšmo dedamoji nagrinėjama atskirai, naudojant skirtingų keitiklių ir operacinių stiprintuvų modelius. Pateikiami grafikai triukšmo dedamųjų įtakai atvaizduoti. Siekiama minimizuoti kiekvienos triukšmo dedamosios įtaką atskirai. Signalu praeinamumui įvertinti nagrinėjamas siaurajuosčio signalo tipas. Skirtingiems keitikliams grandinės parametrai ir stiprintuvo tipas parenkami individualiai, kad signalo ir triukšmo santykis būtų optimalus.

Pateikta spaudai 2005 06 16

DOI: 10.5755/j01.u.55.2.16930