

Development of ultrasonic instrument for the sealed container's liquid level measurement

¹Chen Lei, ¹Dong Xinmin, ¹Han Jie and ²Ye Ping

¹Institute of Vibration Engineering, School of Mechanical Engineering, Zhengzhou University, Zhengzhou, Henan, PRC, 450002,

²College of Mechanical and Electrical Engineering, China University of Mining and Technology, Xuzhou, Jiangsu, PRC, 221008

Introduction

The air-condition compressor used in the passenger train car in China is usually a sealed container, and its breakdown may be caused by mechanical failure, electrical failure or other kinds of failures. But the feedbacks from the maintenance shop indicate that most of the breakdowns took place because the refrigerant oil in the container reduced to a level under a definite line [1]. So it is important to keep the liquid level high enough to ensure that the air-condition run properly. In this paper, the ultrasonic testing method is adopted to accomplish the liquid level measurement. In a traditional ultrasonic testing the flaw detector is the main instrument. The echo wave displayed in the CRT carried detailed information about the inner default of the workpiece, but it cannot be made a further analysis to draw a more accurate conclusion. Therefore the diagnosis conclusions were usually drawn by the observation. So in this paper a programmed software based instrument is developed to accomplish the ultrasonic liquid level measurement. The signal data can be not only displayed in the screen of the developed instrument, but also stored for further analysis to enhance the reliability of the measurement.

The system structure

As shown in Fig. 1, the developed instrument is mainly composed of a transducer, transmitting and receiving circuits, a DAQ (DAQ: Data Acquisition) card and a notebook PC. High voltage electrical pulses produced by the transmitting circuit are applied to the ultrasonic transducer to excite it emitting ultrasonic waves. The echo waves then are amplified by the receiving circuit and acquired by the DAQ card. And at last the analyzing work of these acquired data are carried out with the developed programs in the computer [2].

The ultrasonic transducer is a reversible element. It operates due to the piezoelectric effect, which includes positive and converse effects [3, 4]. Ultrasonic wave is transmitted in accordance with the converse effect and the receiving of the echo wave is in accordance with the positive effect. Fig. 2 shows the principle of the piezoelectric effect. If an electric voltage is applied to electrodes, the piezocrystal will vibrate in the direction of thickness according to polarity of the voltage. If to couple this vibration to the workpiece, the particle of the material will vibrate consequently, and thus in the workpiece the ultrasonic wave propagates. The receiving of the echo wave is quite an opposite process.

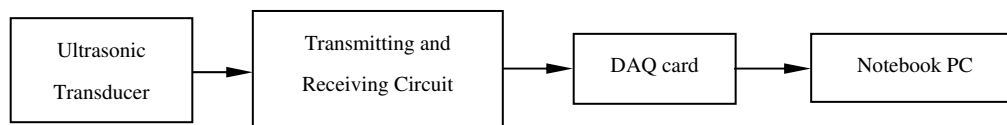

Fig.1: The system structure

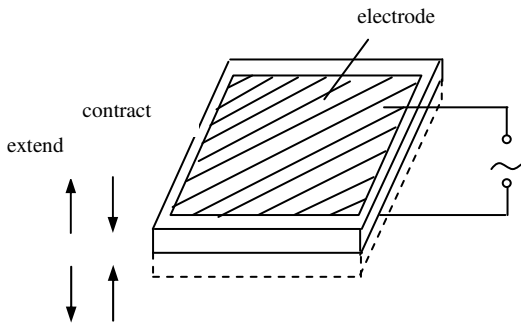

Fig.2: Piezoelectric effect (piezocrystal)

The echo wave brings on the vibration of the piezocrystal. Then the electrical signal generated by the vibration of the piezocrystal is amplified and acquired into the computer for analysis.

Transmitting and receiving circuit

Triggered by the control impulse, the transmitting circuit produces a large amplitude short narrow pulse to excite the transducer emitting the ultrasonic wave. The high voltage needed for the transmitting circuit is increased from a +12V power supply by a transformer. This high voltage charges a large value capacitor and a field effect transistor (IRF830). Fig. 3 shows the working principle of the transmitting circuit. When G (Gate) is in a high level, D (Drain) and S (Source) will be connected, and the capacitor will discharge. Since the charge in the capacitor cannot change abruptly, the high voltage negative pulse will be generated. The crystal emits an ultrasonic wave because of the applied to of this negative pulse.

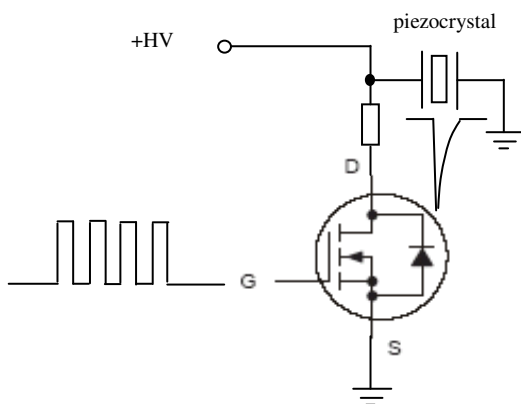

Fig.3: Working principle of the transmitting circuit

After being converted into an electrical signal by the piezocrystal, the echo wave is sent to the receiving circuit. When using an integrated operational amplifier as a preamplifier, the signal is prone to be disturbed because it is weak and has a wide frequency band. So in this paper the discrete component (diode-triode) is adopted in the design of a receiving circuit to realize the first two stage amplification. After the first two stage amplification, the signal then was amplified additionally about 30 times by the integrated operational amplifier LF357N. As follows from the results of testing, the developed receiving circuit has a steady performance and amplification reaches to 60dB. Fig. 4 shows the circuit diagram of the receiving circuit.

The hardware structure of the instrument has the following features:

1. It is not expensive to build such a system. The hardware is mainly composed of a transducer, transmitting and receiving circuits, a DAQ card and a notebook PC. The analog signal is converted into the digital signal with the DAQ card, which communicates with the computer through a paralleled port.

2. It can do fieldworks because of its power supply mode. The power supply of the DAQ card and the transmitting and receiving circuit is provided by a lead accumulator. The notebook PC has its own rechargeable power supply. So, the instrument can work at circumstances without commercial power.

3. The system can be integrated into a portable instrument. Various analyses can be performed by developing a software.

Secondary development of the DAQ card

The DAQ card mainly is composed of the multiplexer, the amplifier, the sampling and hold the analog to digital converter, etc. It communicates with the computer through the *Enhanced Parallel Port*. The program firstly initializes the port base address. The buffers in the DAQ card and the memory link the data acquisition and storage [5]. The driver of the DAQ card accomplishes the control and communication between and DAQ card and the computer. Figure 5 shows the structure of the data acquisition.

The main task of the secondary development of the DAQ card is to develop an application with a friendly user interface. The DLLs (Dynamic Link Library) are called in

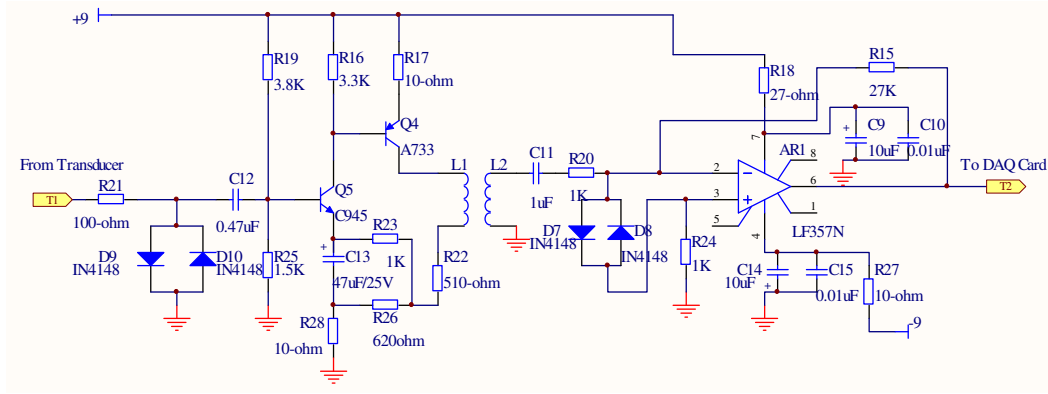

Fig.4. Circuit diagram of the receiving circuit

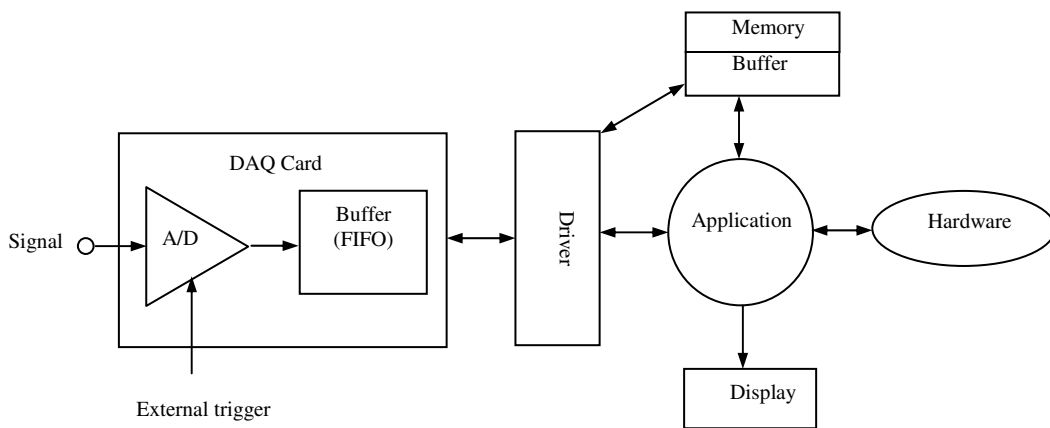

Fig.5. Structure of the data acquisition

the application to drive the hardware of the card and the data in the memory are acquired and displayed on the screen of the computer. When programming the technical support, which is offered by the manufacturer of the DAQ card, is very helpful. The application, which is obtained by the secondary development of the DAQ card, can accomplish data acquisition automatically and has some special functions to analyze the signal. When testing, the developed instrument can not only acquire the source material, but also make real-time analysis of the echo wave and give a conclusion of the relative position between the transducer and the liquid level. Thus the measurement of the liquid level is made easily and automatically.

The software of the instrument consists of drivers and applications. In this paper the software is developed with *Visual Basic 6.0* and *Measurement Studio 6.0*. The *Component Works for VB* of the *Measurement Studio 6.0* software package provides *ActiveX controls* for use in the

VB development environment. These controls include interface control, data analysis and signal processing functions, I/O libraries for data acquisition and instrument control, etc. The use of these controls extends the development environment of *Visual Basic* and makes it easier to develop the software of the instrument. Fig. 6 shows the user interface of the data acquisition section.

The main steps of the secondary development of the DAQ card with *Visual Basic 6.0* and *Measurement Studio 6.0* are as follows:

1. To call the DLLs to drive the hardware in the *Visual Basic* and set the global parameters and the port base address;
2. To develop the data acquisition program that achieves the functions of the digital oscilloscope. This module can store the signal and display it on the screen of the computer, besides it has some functions of data processing.

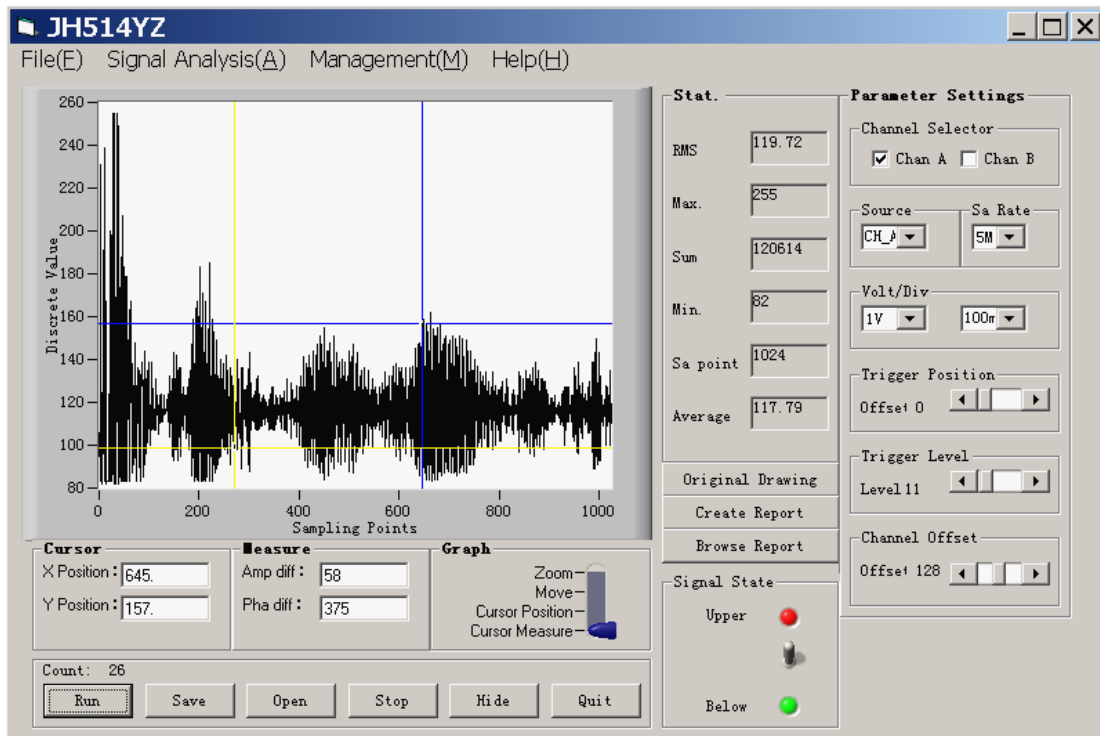

Fig.6. The data acquisition module

3. To program the functions of signal analysis and processing. These functions are programmed by the demands and can analyze the signals in a real time and afterwards.

4. To design file management and data maintenance modules. This modules include report generation and printing part, data storage part and measurement record

database.

5. To package the developed programs into a mounting procedure.

To sum up, the developed software of the instrument in this paper has the following advantages:

1. It can realize the functions of the digital oscilloscope;
2. It has friendly user interfaces and can be easily

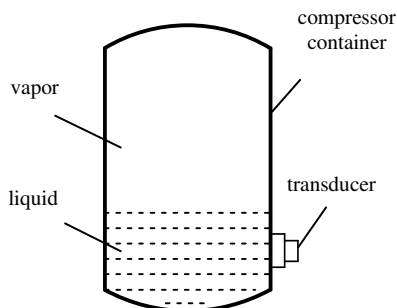

a) placement of the transducer



b) the unpacked compressor container

Fig.7. The compressor and the placement of the transducer

operated;

3. It can analyze data at real-time and afterwards and indicate the relative position between the transducer and liquid level;

4. It can store the testing data in ASCII format and generate the test report automatically;

5. It is made up of several separate modules and can be easily transferred to other fields.

Application of the instrument in the liquid level measurement

A direct contact measurement method is not suitable for the liquid level measurement of the sealed condition compressor. So in this paper the non-contact measurement method using ultrasonic is adopted. In the process of ultrasonic propagation, reflection and refraction will occur at the interface of the two different media. The reflection coefficient depends on the acoustic impedances of the two media. The amplitude of the multiple echo of the steel-vapor interface is much higher than that of the steel-liquid interface. So when moving the transducer up and down, the liquid level can be found out by real-time analyzing of the echo wave. Fig. 7(a) shows the placement of the transducer. Fig. 7(b) is an unpacked compressor container. By analyzing the echo wave when moving the transducer up and down, the instrument indicates the relative position between the transducer and the liquid level. In order to enhance the precision of the measurement, the intersected transducer is used as shown in Fig. 8.



Fig.8. The ultrasonic transducer

It is with a linear focus; the focal length is 5mm, which is the same as the wall thickness of a container. The type of the transducer is 1.25P Φ 12 F5. The transducer is fixed in a shifter, which can move up and down along the wall of a

container. The surveyor's staff fixed on the transducer indicates its height; simultaneously the instrument analyzes the acquired signal in a real time and indicates the position between the transducer and the liquid level. In this way the measurement is accomplished. Fig. 9 shows the echo waves below and upper the liquid level.

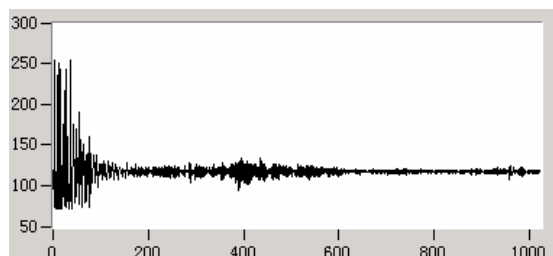

a

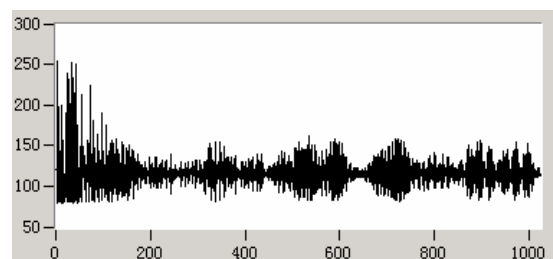

b

Fig.9. The echo waves: a - echo wave of the steel-liquid interface; b - echo wave of the steel-vapor interface

Conclusions

For measurement of the liquid level of the air-condition compressor's sealed container, a measurement method is proposed this paper and the software based ultrasonic test system is developed. The use of the notebook PC technology enhances the automation level of the ultrasonic testing to a certain extent. The developed instrument can acquire ultrasonic signals and analyze them at a real time and afterwards. The friendly user interface makes it can be easily operated. And the modular structure of the instrument makes it can be easily transferred to other relative fields.

Acknowledgment

The author would like to thank Institute of Vibration Engineering of Zheng Zhou University and Dynamic Institute of China University of Mining and Technology for their support.

References

1. **Lei Ch.** Study on the ultrasonic liquid level measurement based on virtual instrument. Thesis for master's degree. China University of mining and technology Xuzhou. PRC. 2004.
2. **Lei Ch., Ping Ye.** Virtual ultrasonic testing system based on LabVIEW and Its DAQ sequence. 5th International symposium on test and measurement. International Academic Publishers. 2005. Vol.1. P.318-318.
3. Xicai He. Sensors and circuits. Publishing house of electronics industry. Beijing. PRC. 2001.
4. **ZeBo Shao.** Non destructive testing. Chemical industry press. Beijing. PRC. 2003.
5. **Leping Yang, Haitao Li, Kai Xiao, Lei Yang.** Generality about the technology of virtual instrument. Publishing house of electronics industry. Beijing. PRC. 2003.

Ch Lei, D. Xinmin, H. Jie, Y. Ping

Ultragarsinis įrenginys skysčio lygiui matuoti uždaruose konteineriuose

Reziumė

Ultragarsas yra vienas iš efektyvių metodų skysčio lygiui matuoti. Sklindant ultragarsui reiškiasi bangų atspindys ir lūžis skirtingų terpių sandūroje. Bangų santykis priklauso nuo abiejų terpių akustinių impedansų. Ši ultragarso charakteristika panaudojama skysčio lygio matavimams uždaruose konteineriuose. Matavimo įrenginys kuriamas programinės įrangos pagrindu. Pateikiama sukurtos sistemos struktūra ir veikimo principas, perdavimo ir priėmimo grandinės, programinė įranga. Įrenginys yra pritaikytas skysčio lygiui matuoti keleivinio traukinio oro kondicionavimo sistemoje. Dėl modulinės struktūros šis įrenginys lengvai gali būti panaudotas kitose giminingose srityse.

Pateika spaudai 2005 06 20

DOI: 10.5755/j01.u.56.3.16940