

Application of linear ultrasonic array to investigation of non-homogeneous media

A. Voleišis¹, R. Šlitteris¹, B. Voleišienė¹, R. Kažys¹, L. Mažeika¹, V. Cicėnas¹, P. Grybauskas²

¹Prof. K. Baršauskas Ultrasound Institute, Kaunas University of Technology,

²Institute of Cardiology, Kaunas University of Medicine

Introduction

Ultrasonic methods are widely used for investigation of structure of various media. There are some fields of applications, e.g. non-homogeneous non-stationary media, where traditional one-transducer methods do not give satisfactory results because scanning can not be applied. For example, it was established experimentally, that ultrasound velocity in a blood sample in a small volume chamber is changing in a specific way during the whole clotting process [1, 2], but this variation reflects an integral view of the sample structure, clot plus serum, while an interest exists only in a clot structure [3].

Experiments revealed that in chemical polymerization specific velocity variations are observed as well [4]. Both in blood clotting and polymerization, the structure of a medium varies in volume and in the time domain [5]. So, the results of ultrasonic measurements depend on ultrasonic beam position in space and its direction with respect to horizon. It is evident, because blood corpuscles [6] and macromolecules in a chemical reaction [5] are influenced by the gravitation.

The first quantitative results concerning structure variations in volume and in the time domain were obtained in our previous work [5]. These experiments with four channel chamber were performed in a through-transmission mode. The identical channels were obtained cutting the circular transducers (transmitter and receiver) into two perpendicular directions. An axial symmetry of the channels was exploited in order to equalize the diffraction effects. Such a chamber enabled to provide experiments practically only with two orientations of the

wave propagation: vertical and horizontal. Obviously, the gravitation influence on the results in both orientations is quite different. Additional rotation of the chamber around the axis in a horizontal orientation gives no additional information due to the peculiarity of the transducers geometry. Analysis of the results showed that a more sophisticated geometry of the channel transducers is necessary in order to obtain clear sections of the medium (blood clot, etc.).

Measurement system

The measurement system for volumetric investigation of non-stationary and non-homogeneous media is based on application of serial measurement devices, a specially designed ultrasonic measurement chamber and specific electronic equipment. The measurement system is presented in Fig.1.

The system enables to collect the signals received by each channel in series in the time domain. The pulse generator HP 33120A sets the period for ultrasonic pulses excitation by control of operation and commutation of four excitation generators and amplifiers for each particular channel in series. The HP 54645A type oscilloscope is used for digitalization of the received signals with the 100 MHz sampling rate. The digitized signals are acquired in a personal computer PC for storage and data processing. This system enables to investigate non-stationary process with the sampling period of two seconds. The four channel measurement chamber is in a water bath with a fixed temperature. The temperature is set 36.5 °C and kept within ± 0.01 °C

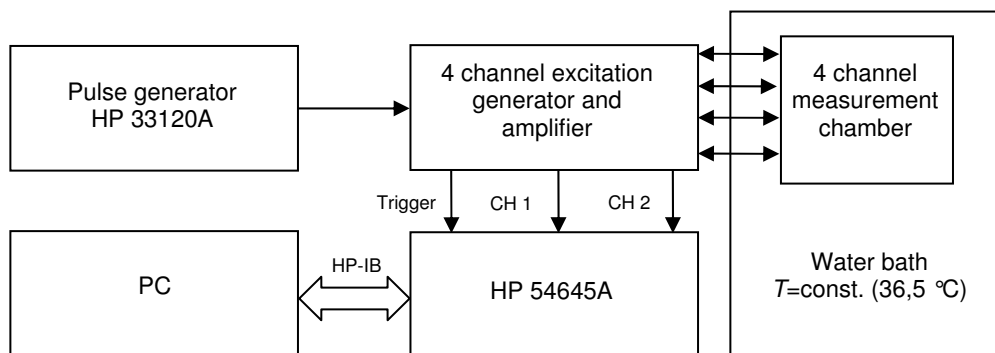

Fig. 1. The block diagram of the measurement system used for the investigation of non-homogeneous media

Chamber

A. Array approach

For a more detailed analysis of the processes in non-stationary media a new miniature four-channel chamber with a strip-like transducer array was developed. It operates in a pulse-echo mode. For this purpose ultrasonic pulses are periodically transmitted into the sample through a buffer rod, and they are reflected from the interface rod/sample and from the bottom of the chamber (Fig 2a).

The method is based on measurement of the delay times of two reflected ultrasonic pulses [2]. The ultrasound velocities in the sample are determined from the difference of the delay times in each channel and the length of the measurement chamber, which is found from the calibration procedure in distilled water. This length is slightly different for each channel. After the proper calibration, in the case of a stationary homogeneous liquid all four channels must give the same ultrasonic velocity within the limits of accuracy and it can not change in time. More, the results must be independent of the chamber orientation with respect to the gravitation.

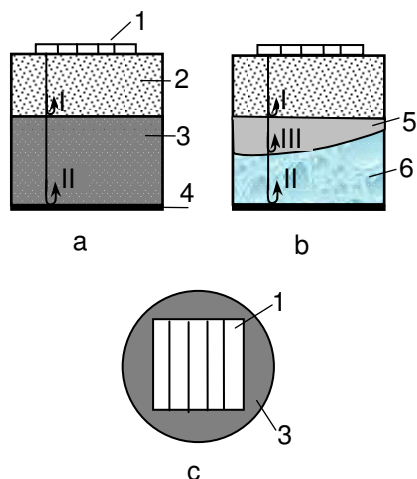

Fig. 2. Four channel chamber with a transducer array, operating in a pulse-echo mode (vertical wave propagation): a - filled with blood; b - blood after the clotting; c - top view of the array; 1-array; 2-rod; 3-sample; 4-reflector; 5-serum; 6-clot

A different case is observed when structural changes in non-stationary liquids are investigated. Typical processes are sedimentation of blood cells in a citrated blood, blood clotting, polymerization reactions in chemistry, etc. Fig. 2b represents a clot formation at the bottom of the chamber, while blood serum concentrates in the upper volume. Significantly, the interface between the clot and the serum is irregular; it depends on the chamber orientation and gravitation, tension forces of the clot, etc. Some minor ultrasonic reflection can be seen from this interface, because impedances of the clot and serum are very close. It is clear that in a vertical orientation of the wave propagation all channels give slightly different results, as signal paths in serum and clot are different. Chamber inclination influences the clot interface and thus results obtained in different channels. In the case of a single integral transducer [2] the clotting investigation can not be

repeatable exactly as the results depend on the clot/serum interface shape which is somewhat accidental.

The blood clot formation is an exceptional example. In other application areas, such as investigation of sedimentation, polymerization, etc., the multichannel approach in the case of the vertical wave propagation can not give essentially new results in comparison with measurement performed with a single ultrasonic transducer.

In a horizontal wave propagation two main orientations of the transducer array are possible: strips of the array are vertical or horizontal (Fig. 3). These two orientations differ principally.

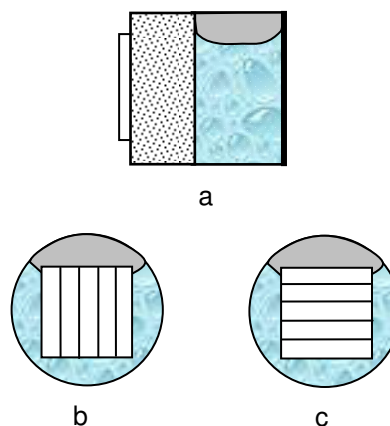

Fig. 3. Horizontal wave propagation in a four channel chamber, filled with a clotting blood: a - side view; b - strip of the array are vertical; c - horizontal strip

In Fig. 3b all channels are in similar conditions (the lateral channels are influenced by the walls of the chamber again), and the course of process developing in a liquid medium must be nearly identical. The most interesting is the last case (Fig 3c): all channels measure ultrasound velocities in different layers, which have different acoustic properties due to the gravitation influence. For example, in the upper channel the wave propagates through the blood serum, in other channels through different parts of the clot. In other applications Fig. 3c orientation is most promising also. In recent studies it has been found that gravitation has an influence on microscopic structures, e.g. as small as human cell. It was supposed that gravitational forces might have an effect on blood clotting, especially on the action of the thrombocytes, participating in blood clotting [6].

B. Implementation

In a practical realization the chamber was made from brass, coated by nickel and finally by gold. Brass was selected for its thermal properties, while gold coating for its excellent biocompatibility [7], which is necessary in order not to influence the blood clotting process. It is a perfect coating for other applications as well. The chamber inner diameter is 13 mm, the length is 6 mm, so the volume is 0.8 ml. The waveguide is 5 mm length and it is made of plastics with low ultrasonic absorption and is biocompatible as well. Its acoustic impedance is 2.3 MRayl, thus it is close to the impedance of the sample ($1.5 \div 2$ MRayl). Consequently, the reference reflection

from the interface rod/sample is rather weak. The transducer array is 8×8 mm, a single strip is 2 mm width. The array is glued to the rod. For larger damping and shortening of the pulses the backing from epoxy+alumina is attached to the array. The chamber is filled through a medical needle with a syringe.

Typical one channel signals are shown in Fig. 3a. The reference signal 1 appears at $4.2 \mu\text{s}$, while the reflection 2 from the metallic polished cell bottom at $\sim 12.2 \mu\text{s}$ depending on the sample. Perculiarity of this chamber is a short buffer rod 5 mm long instead of 15 mm [2]. Multiple reflections in the rod did not influence the main reflection. The second reflection in the rod is observed at $8.4 \mu\text{s}$, the third must be at $12.6 \mu\text{s}$, but it is not visible due to the close impedances of the rod and water (Fig 4b).

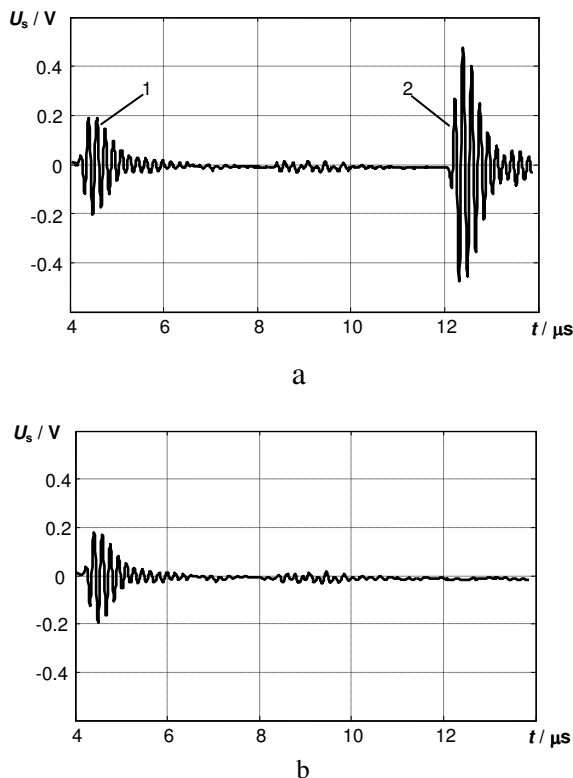

Fig. 4. One channel signals in the measurement chamber filled with water: a – reference and informative signals; b – multiple reflections in the rod when the reflector is masked by an absorber

Due to divergence of the transducers beams there may be cross-talks between channels, so they operate in turn: the next channel is switched on when all reverberations in the previous channel die.

C. Field

The propagation of ultrasonic signals excited by a single strip-like transducer in the measurement chamber was calculated using a diffraction model for arbitrary contoured planar transducers [8]. The results of the numeric simulation show that the ultrasonic signal propagates forward through the measurement chamber and back in the space contoured by the strip shape.

Distributions of the ultrasonic field at different distances from the excited stripe transducer are presented in Fig. 5 and 6. The loss of ultrasonic energy due to the spreading of ultrasonic waves in the media is shown in Fig. 5b.

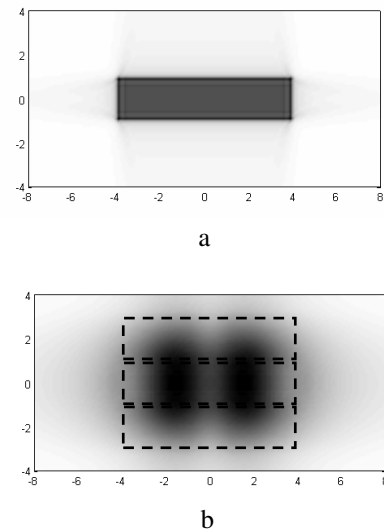

Fig.5. Distribution of an ultrasonic field on the surface of the strip at the excitation (a) and reception (b) instants. The position and the size of the strips are shown by the dotted lines. Scale is given in millimeters

The ultrasonic beam after the propagation in the rod and medium returns to the array widened and is received by the adjacent strips as well (Fig. 5b). Thus the array strips should not be excited simultaneously, therefore they operate in turn.

Ultrasonic fields at various cross-sections of the measurement chamber are shown in Fig. 6.

Distribution of an ultrasonic energy when the signal passes forward and back through the measurement chamber shows that ultrasonic waves interact with and can give the information only from the selected sector of the medium under investigation.

Experimental

A. Homogeneous medium

After the calibration in a distilled water and determination of the individual chamber length in each channel, measurements were provided in a homogeneous 0.9 % NaCl solution. As presumed, measurement results in different channels did not depend on the chamber and array orientation. Mean value differences between the channels reaches 5 cm/s. (Fig. 7). Irregularities within 3 cm/s are due to the operation of water thermostat and are synchronized in all channels. Increase of the mean ultrasound velocity up to 4 cm/s is observed as the temperature drifted within $0.02 \text{ }^\circ\text{C}$.

The statistics analysis shows that at a stable temperature in a homogeneous medium the measured values of ultrasound velocity has distribution close to normal (Fig. 8) and the standard ultrasound velocity error $\sigma=0.03 \text{ m/s}$.

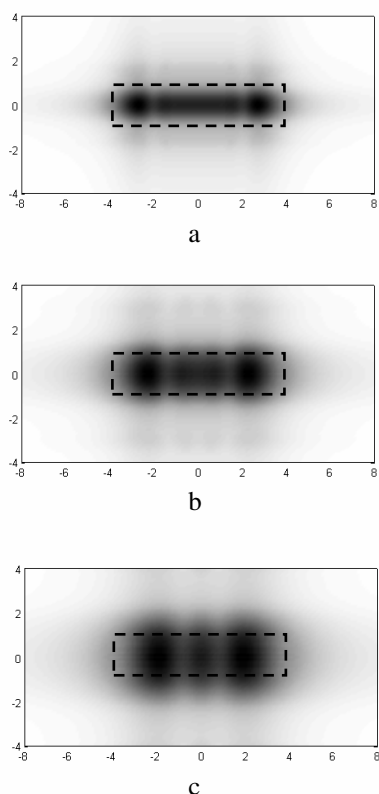

Fig.6. Distribution of the ultrasonic field at various cross-sections of the measurement chamber: a – at the interface rod/medium; b – at the reflector; c – at the interface medium/rod after the propagation and reflection

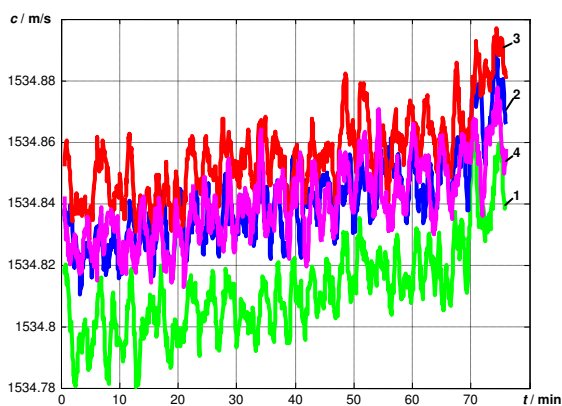

Fig. 7. Channel identity check in a homogeneous 0.9 % NaCl solution

B. Chemical polymerization

Free-radical chain polymerization reaction of acrylamide, depending on composition, can be somewhat similar to the blood clotting from the point of view of ultrasound velocity variations, so it can be used in medical experiments as a reference medium. It was supposed that gravitation influence on the course of a reaction may be investigated most successfully if the wave propagation is

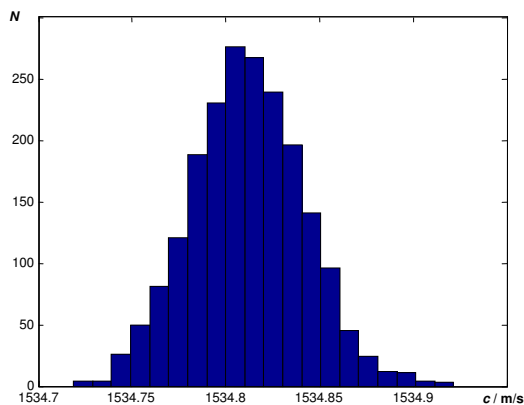
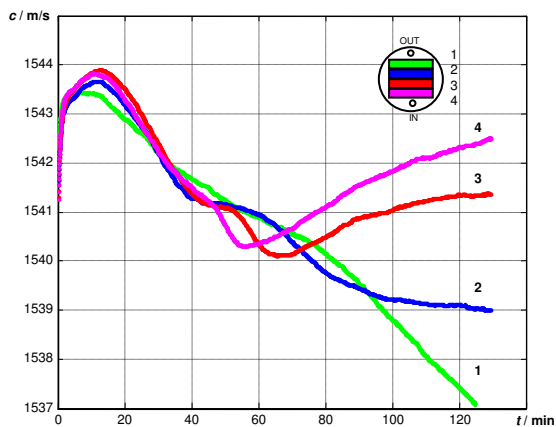

Fig. 8. Histogram of the measured values of the ultrasound velocity in a homogenous 0.9 % NaCl solution

horizontal and strips of the array are horizontal as well (Fig.2c). The composition of the acrylamide polymerization compound mixture for experiments was the same as in our previous work [5]: 5ml of acrylamide $\text{CH}_2=\text{CHNH}_2$ 5% on the mixture weight, 2 ml of potassium persulphate $\text{K}_2\text{S}_2\text{O}_8$ at the concentration 0.04 moles/liter, 2 ml of sodium thiosulphate $\text{Na}_2\text{S}_2\text{O}_8 \times 5 \text{ H}_2\text{O}$ at the concentration 1×10^{-4} moles/liter and 1 ml of distilled water.

Fig. 9a and Fig. 9b present the courses of a polymerization reaction obtained in two separate experiments. The main character of the curves and their distribution between channels is similar, but the second reaction is more intense: it begins earlier and the span of the curves is bigger. This difference may be explained by the peculiarities of the polymerization reactions and inevitable errors of composition.

As seen, at the beginning of polymerization in both cases the dependence of the ultrasound velocity is almost identical in all channels, but later the difference is very evident. It may be for some reasons. First of all for the peculiarity of the radical polymerization because the formation and life time of free radicals vary with time. There are many events which depend on probability if two growing chains can combine and form a carbon-carbon bond, effectively killing both chains, or can accidentally meet two radicals and in the following way they become the ions causing disproportion and termination of reaction. Another reason may be as a consequence of the errors of preparation of the initial solutions. Common for these two experiments is the the course of polymerization in the upper channels: the ultrasound velocity decreases rapidly (curves 1). So, in the upper parts of the chamber the rate of polymerization is very fast; the amount of small and light species capable of initiating the polymerization is very large what leads to formation of many new active centers which propagate macromolecules with a small molecular mass; the character of the curves reflects this behavior. An absolutely different course of acrylamide polymerization may be seen in the lower part of the chamber (channel 4). Probably, that is due the gravity effect. From the instant when ultrasound velocity decreases to a minimum (Fig. 9a after 50 min, 9b after 20 min) thereafter it increases monotonically.



a

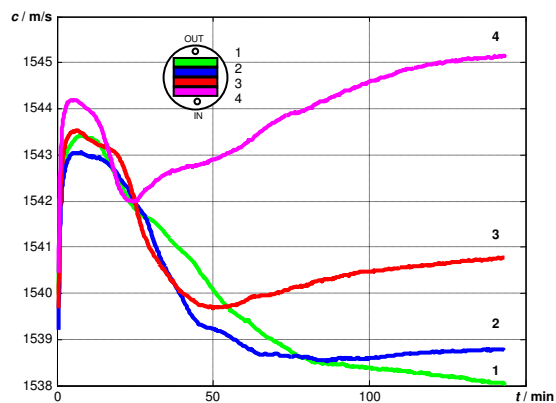

b

Fig. 9. Acrylamide polymerization curves in two experiments (a and b), when wave propagation and strip of the array are horizontal

Ultrasonic wave propagation is sensitive to growing of polymer macromolecular chains and on the other hand the length of chain reaction depends on the ratio of amount of active particles that are generated in time unit to numbers of these particles, which are produced for growing radical.

As expected, in the case of wave propagation in the vertical direction where the influence of gravitation forces on radical particles and macromolecules in all channels is identical, the courses of reaction are nearly similar (Fig. 10), especially in the central channels 2 and 3. The lateral channels 1 and 4 differ more, may be due to the influence of the chamber walls. Note, that the polymerization reaction is not uniform in time and space domains as well.

For a better understanding of the influence of wave propagation direction and array orientation with respect to the gravitation, ultrasonic parameters characterizing all three identical polymerization reactions are collected in Table 1.

Table 1. Ultrasonic parameters of identical polymerization reactions obtained at different orientations of the array

Channel No	Δc , m/s		
	Fig. 9a, 9b		Fig. 10
1	6.0	5.1	0.6 (1.1)
2	4.6	4.2	1.2 (1.6)
3	2.6 (3.8)	2.9 (3.8)	1.3 (1.7)
4	1.5 (3.5)	-0.8 (3.0)	1.1 (1.4)

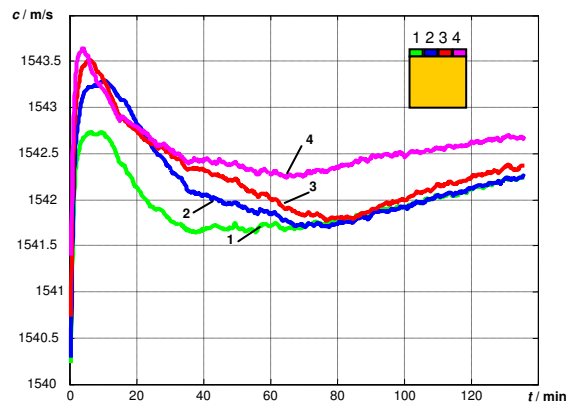

Fig. 10. Polymerization curves obtained in the case of vertical wave propagation, when the influence of gravitation in all channels is identical

The ultrasound velocity differences Δc are compared at 120 min with reference to the first maximum of the curves, where the temperature stabilisation comes to an end. The room temperature polymerization mixture is injected to the 36.5°C chamber, so in the initial phase reaction takes place along with the temperature stabilisation of the sample. If the ultrasound velocity variation is not uniform and has an extremum, additionally in brackets (Table 1) the largest velocity differences are given.

From this table it is evident the significant difference of the results obtained in both orientations of the array, which is caused by the gravitation influence and reaction non-uniformity in space domains. Also, from the results presented follows importance of proper definition of ultrasonic experiment conditions.

From the family of curves (Fig. 9a) obtained with the strip-like array an integral polymerization curve was calculated corresponding to the single 8x8 mm transducer. It is shown in Fig. 11 and corresponds to the results of investigations carried out earlier with one-channel chamber [2].

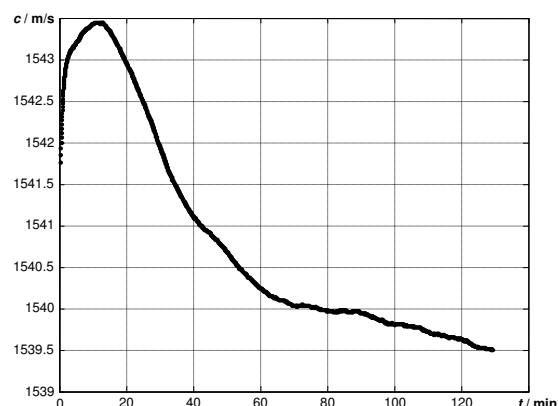

Fig. 11. An integral polymerization curve obtained from the four-channel results

From the comparison of these two figures it is evident the advantage of the array approach in these experiments

as it gives more information about the polymerization process.

C. Coagulation of blood

A typical non homogeneous medium is native human blood which undergoes a complex reaction called clot formation or coagulation. As it is known, the human blood is composed mostly of a water-fluid part (78 %) called plasma, in which red (erythrocytes) and white (leucocytes) corpuscles as well as platelets (thrombocytes) are suspended. The rest 22 % are solids, of which 18.5 % are proteins. Platelets, which are very small and irregularly shaped structures, contain a substance participating in blood clotting. The clotting process begins immediately after the blood escapes from the organism. Clotting involves a cascade of molecular interactions. Platelets release fibrinogen, which is converted into fibrin. It forms a dense fibrous mat to which more platelets or other blood cells attach forming a clot. In a clot formation, the fibrin polymerization mechanism plays a significant role. Moreover, the same peptide groups – CO–NH – are included in the composition of polyacrilamide as in final product of blood coagulation, e.g. fibrin, with the difference that structure of fibrin is based on α -amino acids.

Clotted blood consists of two parts. The first part is the clot which includes the formed elements and some of the proteins. The second is the serum, a clear yellow liquid that is similar to plasma except that it lacks fibrinogen. The serum separates from the clot and is concentrated above it.

As mentioned above, during the acrylamide polymerization reaction at the bottom of the chamber a higher ultrasound velocity was observed as macromolecules with longer chains concentrated here. It was supposed that the same effect must take place in clotting blood as larger blood particles are affected by gravitation more.

Some measurements in native coagulating human blood were performed with horizontal strips of the array. Fig. 12a represents the results of a typical experiment and shows velocity variations during coagulation, retraction and lysis (>1 h).

As a rule, in various blood samples a similar distribution of velocity values between channels was observed (upper channel – minimal velocity, etc.), though in each case an individual character of the curves was registered. It must be emphasized that the upper channel corresponds mainly to the velocity in the serum, the rest three – in the clot.

In the initial phase of the coagulation process (<10 min) clot formation takes place, and it is the most important phase. Typical velocity variations in another sample of blood of the same person are shown in Fig. 12b. The difference in velocity values between the channels is less than 0.4 m/s, while later at 20 min it reaches 20 m/s. Note, that in the lower channels 3 and 4 velocity peaks and hollows are almost synchronised, while in the upper channel 1 curve is different and only it is characterized with a clear peak at the beginning of the process after 2 min. In the adjacent second channel velocity variations are similar but smoother.

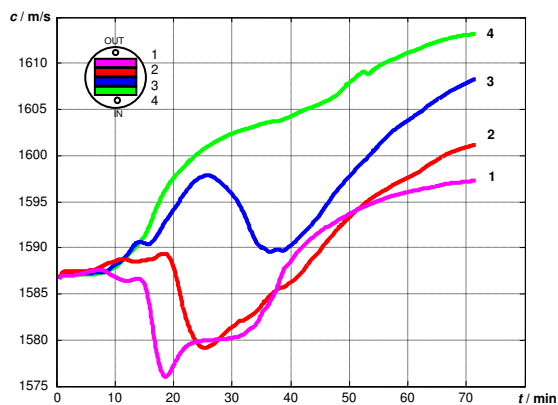

a

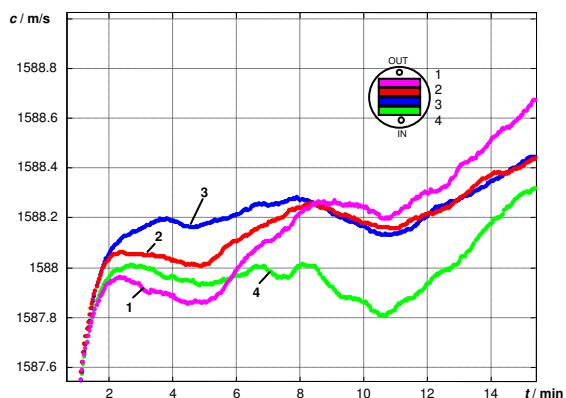

b

Fig. 12. Ultrasound velocity variations in a native human blood observed in different channels during: a - the coagulation, clot retraction and lysis; b - in the initial clot formation phase

Obviously, these velocity variations in different slits of the clot during its formation reflect its structure, and this ultrasonic method may be promising in a future.

Conclusions

An ultrasonic array approach is proposed for investigation of the structure of a liquid non-stationary medium. Numerous experiments were performed with chemical polymerization and native human blood clotting. An optimal wave propagation direction and array orientation with respect to the gravitation vector was found, which gives the best information about structure in various sections of the medium.

References

1. Voleišis A., Kažys R., Mažeika L., Šlīteris R., Voleišienė B. Ultrasonic technique for investigation of structural properties of biological fluids. The Journal of the Acoustical Society of America. 1999. Vol. 105, Issue 2, P. 1369-1370.
2. Voleišis A., Kažys R., Mažeika L., Šlīteris R., Voleišienė B., Grybauskas P. Ultrasonic method for the whole blood coagulation analysis. Ultrasonics, Elsevier. 2002. Vol. 40. P. 101-107.
3. Wolberg A.S., Gabriel D.A., Hoffman M. Analyzing fibrin clot structure using a microplate reader. Blood Coagulation and fibrinolysis. 2002. 13(6). P. 533-539.

4. **Voleišienė B., Voleišis A., Kažys R., Mažeika L., Šliteris R.** Dynamic calibration method for ultrasonic coagulometry. *Ultragarsas (Ultrasound)*. Kaunas: Technologija. 2003. Nr.3(44). P. 45-549.
5. **Kažys R., Voleišis A., Voleišienė B., Šliteris R., Mažeika L., Grybauskas P.** Ultrasonic multi-channel method for investigation of non-stationary biologic liquids. *Ultragarsas (Ultrasound)*. Kaunas: Technologija. 2003. Nr.4(49). P. 53-57.
6. **De Marco L., Perris R., Cozzi M.R., Mazzucato M.** Blood clotting in space. *Journal of Biological Regulators and homeostatic Agents*. 2004. Vol.18. P. 187-192.
7. **Shukla R., Bansal V., Chaudhary M., Basu A., Bhonde R.R., Sastry M.** Biocompatibility of gold nanoparticles and their endocytotic fate inside the cellular compartment: a microscopic overview. *Langmuir (the ACS journal of surfaces of colloids)*. 2005 Nov 8. 21(23). P. 10644-54.
8. **Mažeika L., Cicėnas V.** The method for the calculation of ultrasonic fields of planar free form transducers. *Ultragarsas (Ultrasound)*. Kaunas: Technologija. 2001. Nr.4(41). P. 12-17.

A. Voleišis, R. Šliteris, B. Voleišienė, R. Kažys, L. Mažeika, V. Cicėnas, P. Grybauskas

Ultragarsinių keitiklių gardelės taikymas terpės nevienalytiškumui tirti

Reziumė

Miniatiūrinės akustinės kameros su ultragarsinių keitiklių gardele pagrindu sukurta matavimo sistema terpės nevienalytiškumui tirti. Nustatyti sistemos metrologiniai parametrai, apskaičiuotas gardelės elemento laukas. Nagrinėta gardelės orientavimo įtaka ultragarso sklaidimo krypties ir gravitacijos atžvilgiu, tiriant tipines nevienalytes terpes: chemines, kuriose vyksta polimerizacijos reakcija ir biologines, kuriose vyksta struktūriniai pokyčiai (pvz., natyvinio kraujo krešėjimo procesas). Parodytas siūlomo metodo perspektyvumas tiriant terpės struktūrinius pokyčius erdvėje ir laike.

Pateikta spaudai 2005 12 16

DOI: 10.5755/j01.u.57.4.16947