

## Diagnostic testing of the comparator carriage vibrations

A. Kilikevičius\*, V. Vekteris\*\*

\* Department of Machines Engineering Vilnius Gediminas Technical University J. Basanavičiaus Str. 28 LT-2009 Vilnius, Lithuania mob. phone: +370 677 55819 E-mail: akilikevicius@gmail.com

\*\* Department of Technical Disciplines Vilnius Pedagogic University Studentų Str. 39, LT-08106 Vilnius, Lithuania Phone: +370 5 2744734, Fax:+370 52745043, mob. phone: +370 682 70162 E-mail: vekteris@me.vtu.lt

### Abstract

Diagnostic testing of the comparator carriage vibrations is discussed in this paper. A dynamic model of a carriage and mathematical equations are presented. A level of carriage vibrations is experimentally determined in various operating and environmental situations, and the effect thereof on the measurement accuracy is estimated.

**Keywords:** diagnostic, comparator, vibrations, dynamic model, testing.

### Introduction

The world practice witnesses increased focusing on the improvement of line gauge technologies and application thereof in length measurement and precise controlled motion systems. Modern precision scale production technologies enable to create small-step displacement transducers with measuring possibilities that come close to those of optical interferometers. Currently, line gauges with 0.125 nm (1.25 Å) resolution are used in precision devices. A rapid advance of technologies, primarily micro- and nanotechnologies as well as microelectromechanic system (MEMS) technologies raises higher and higher precision requirements, measuring speed requirements and other requirements thus stimulating creation of new precision length calibration systems [1, 2, 3, 4].

Line gauges are calibrated by means of optical interference comparators with a sliding microscope for scale line viewing and with a sliding measurement scale. Interferometric measuring systems are used for precise measurement of the displacement of these sliding parts.

Generally, the sources of interferometer stabilized frequency radiation are double-frequency He-Ne lasers.

In the course of Lithuania's integration into the EU metrological space and in pursuance of future participation in the international comparison of line standards the calibration uncertainty of the created length gauge (a reference laboratory with the laser interference line-standards comparator) should not exceed 0.1 μm/m.

The paper covers analysis of the comparator carriage vibrations with intent to diagnose the origin of measurement errors.

### Test object

The structural diagram of the equipment is shown in Fig. 1. It is based on a line-standards comparator with a sliding microscope and a stationary scale. The comparator's frame is made from granite and is mounted on vibration-proof supports; the microscope holder moves on air guides.

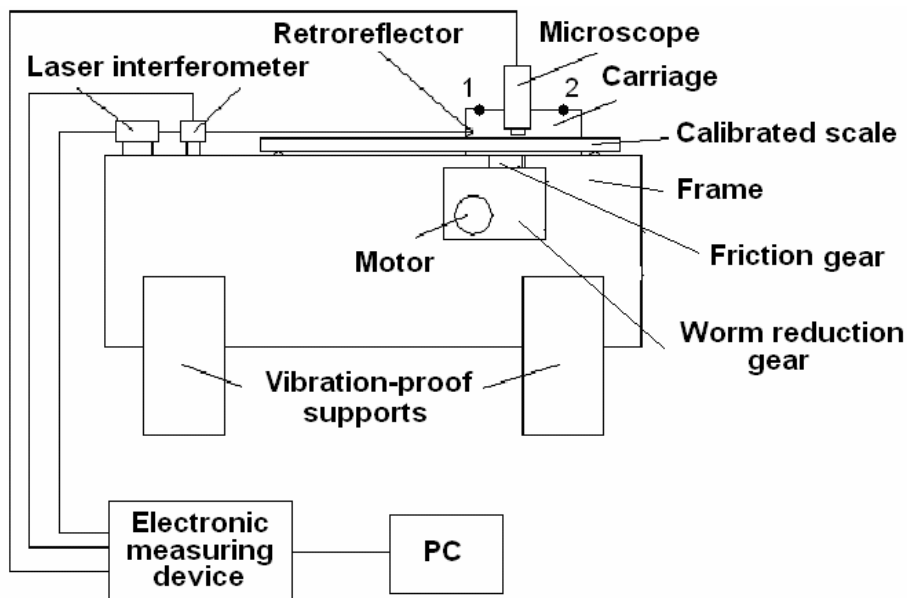

Fig. 1. A structural diagram of the comparator and vibration measuring points

The position of lines of the calibrated gauge is precisely determined (calculated) by processing the measurement data and estimating corrections for geometrical, instrumental and environmental errors.

The comparator is installed in a standard (conditioned) room.

The whole operation of the comparator and error compensation are computer-controlled.

**Modeling**

Fig. 2 shows a dynamic comparator carriage model.

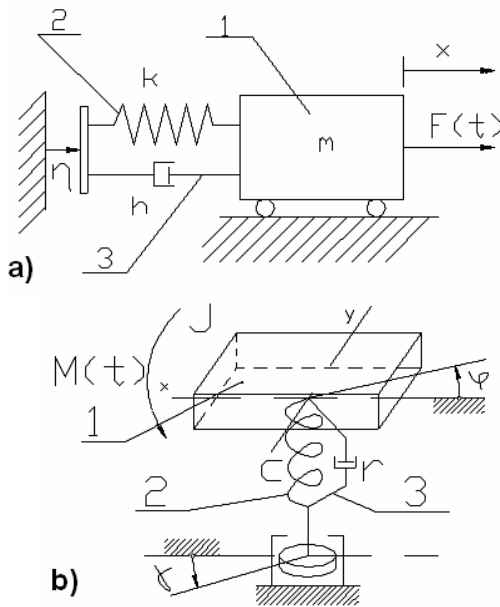

Fig. 2. A dynamic carriage model: a – of rectilinear motion; b – of angular motion.

Comparator carriage 1 is considered an absolutely solid body with parameters  $m$  (weight, kg) and  $J$  (moment of inertia,  $\text{kgm}^2$ ). System coefficient of rigidity ( $k, c$ ) 2 and damping coefficient ( $h, r$ ) 3 are found experimentally.  $F(t)$  is a driving force that delivers the carriage to the required point.  $\eta$  – vibrations of the foundation in  $x$  direction, and  $\gamma$  – respective vibrations of the foundation in  $\varphi$  direction.

When a dynamic model is obtained (Fig. 2) a mathematical model of the tested system is created (vibration equation). To this end Lagrange's equation of the second type is used [5]:

$$\frac{d}{dt} \left( \frac{dT}{dq_i} \right) - \frac{dT}{dq_i} + \frac{d\Phi}{dq_i} + \frac{d\Pi}{dq_i} = Q_i(t) \quad (1)$$

here  $T, \Pi$  are the system's kinetic and potential energy;  $\Phi$  – dissipation function;  $q_i$  –  $i$ -th generalized coordinate;  $Q_i(t)$  – generalized force acting in accordance with coordinate  $q_i$ .

Using Lagrange's Eq. 1 the carriage vibration Eq. 2 and 3 are created after estimating the vibrations of the foundation:

$$m\ddot{x} + h\dot{x} + kx = F(t) + h\dot{\eta}(t) + k\eta(t) \quad (2)$$

$$J\ddot{\varphi} + r\dot{\varphi} + c\varphi = M(t) + r\dot{\gamma}(t) + c\gamma(t) \quad (3)$$

After performing modeling by means of Matlab 6.1 and Origin 6.1 software packages we obtain the results presented in Fig. 3 (a) and (b).

**Diagnostic Tests**

To check the effect of vibrations on the comparator carriage a diagnostic measurement system was created (Fig. 4) by means of which vibrations were measured.

The obtained measurement results are presented in Figs. 5-8.

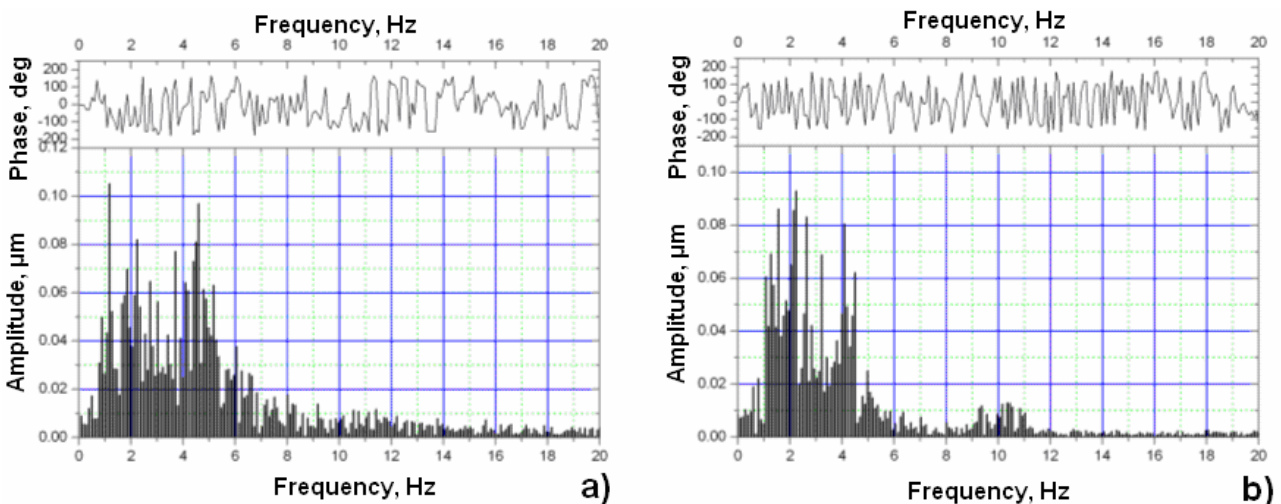

Fig. 3. Spectrum of the displacement signal (Point 1 and 2 in horizontal direction)

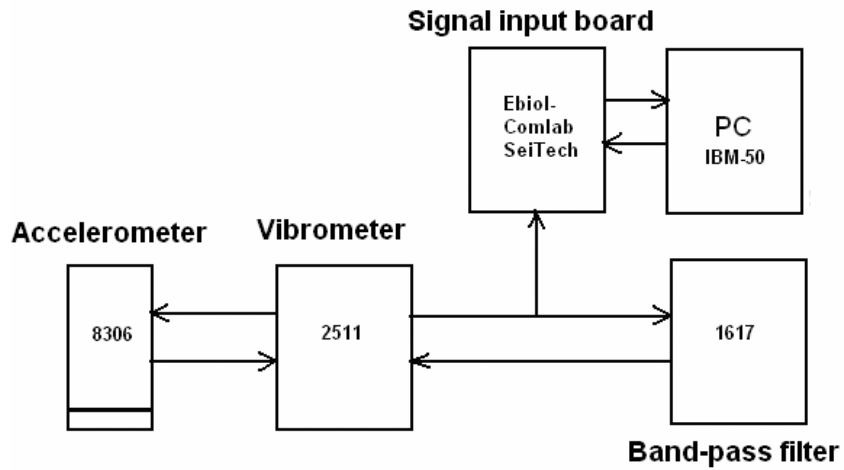

Fig. 4. Diagnostic measurement system with Brüel & Kjær measuring devices

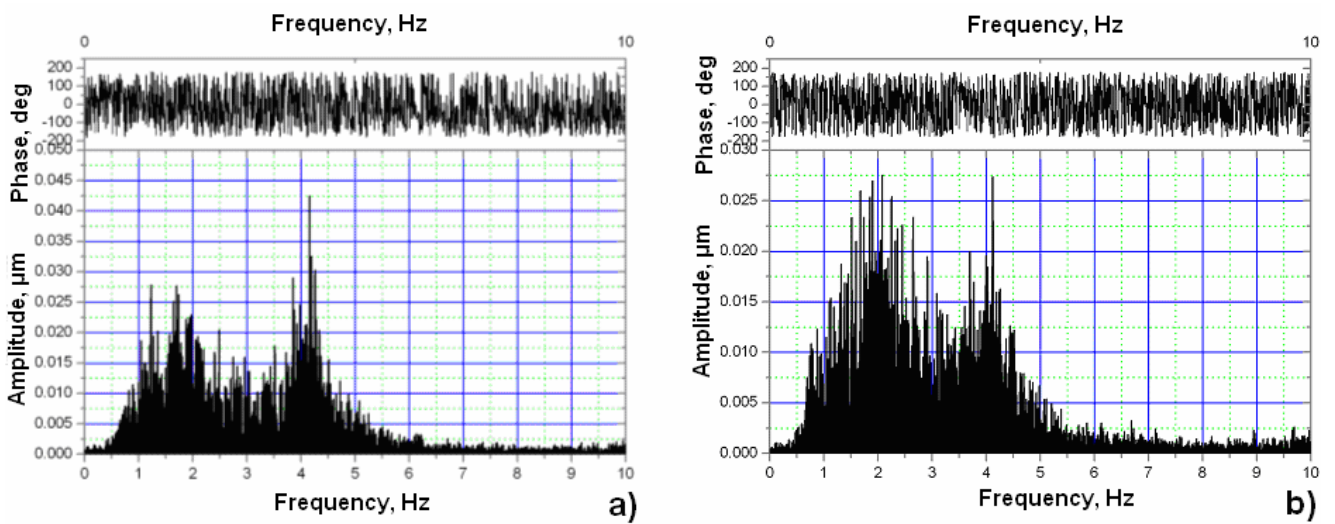

Fig. 5. Spectrum of the displacement signal, point 1 in horizontal direction, a) with air in the carriage and support, b) without air in the carriage and with air in the support

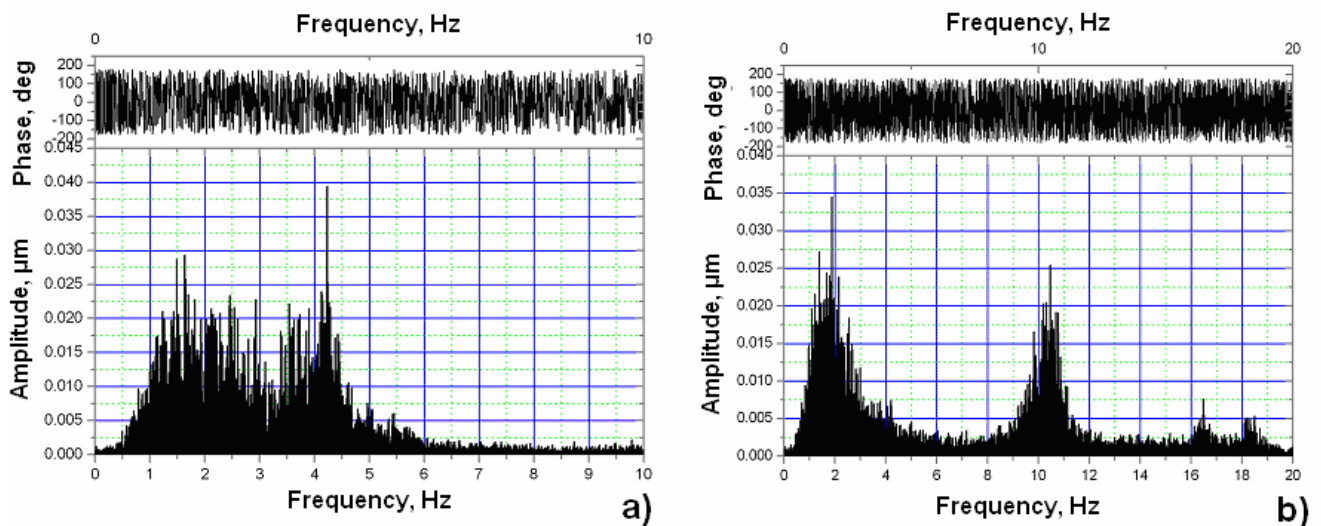

Fig. 6. Spectrum of the displacement signal, point 1 in vertical direction, a) with air in the carriage and support, b) without air in the carriage and with air in the support

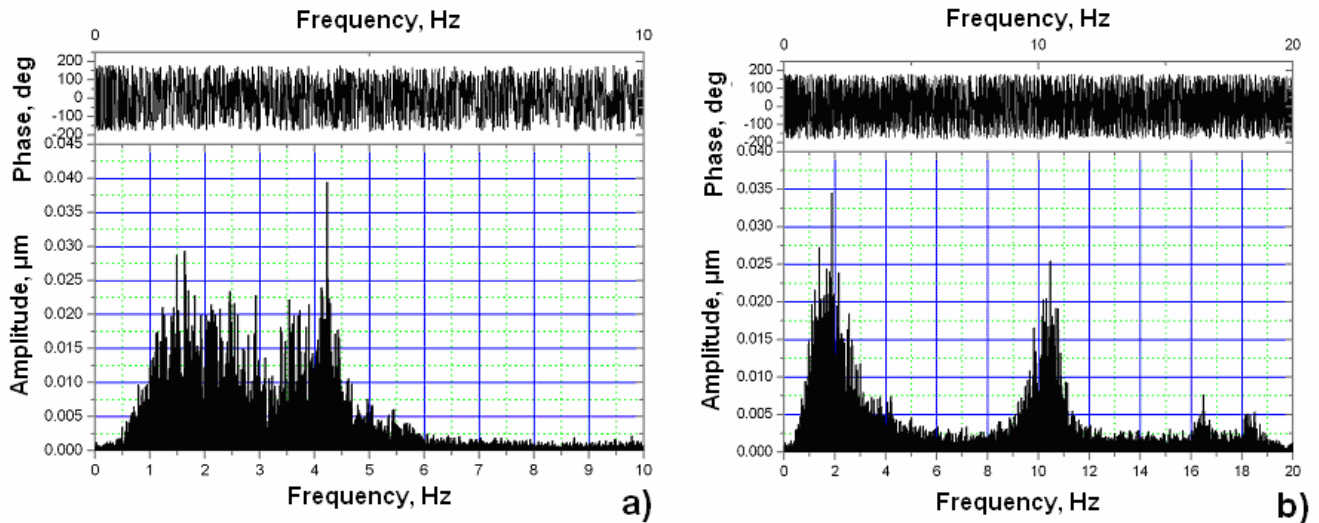

Fig. 7. Spectrum of the displacement signal, point 2 in horizontal direction, a) with air in the carriage and support, b) with air in the carriage and without air in the support

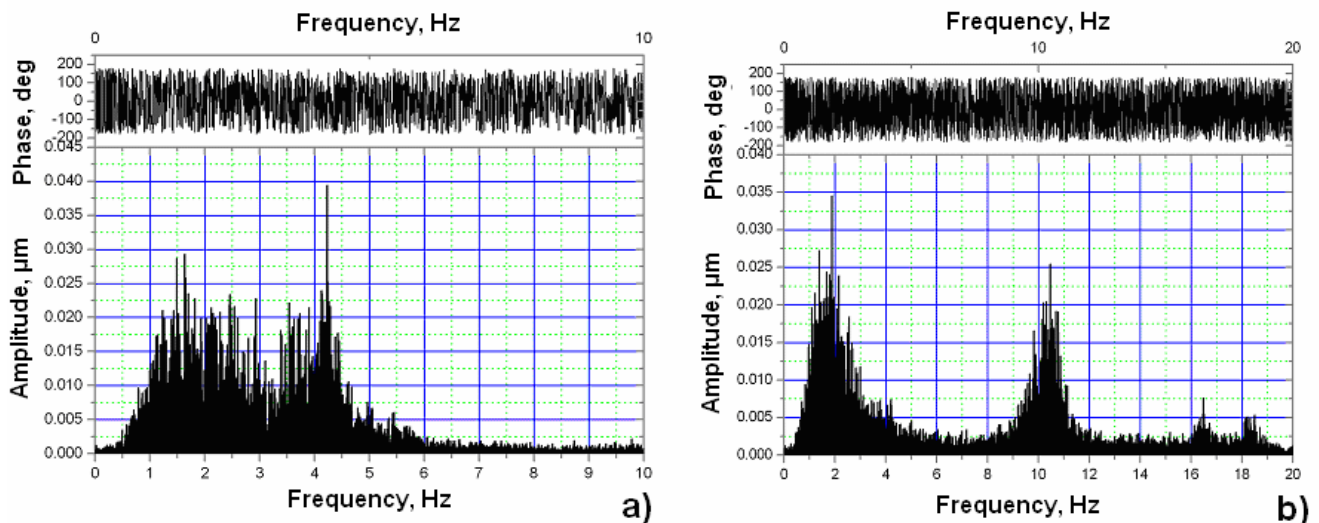

Fig. 8. Spectrum of the displacement signal, point 2 in vertical direction, a) with air in the carriage and support, b) with air in the carriage and without air in the support

## Discussion of the results

The obtained experimental results show that the spectral amplitudes of the carriage vibrations at 2 – 4 Hz frequencies fluctuate from 0.02 to 0.04  $\mu\text{m}$ , whereas at 10 – 13 Hz frequencies - from 0.02 to 0.025  $\mu\text{m}$ , at 17 – 27 Hz from 0.005 to 0.015  $\mu\text{m}$ , amplitudes at other frequencies are inconsiderable. Results obtained in theoretical tests are markedly expressed at 2 – 4 Hz frequencies only, where amplitudes reach up to 0.1  $\mu\text{m}$ . This is related to inaccurate setting of parameters of differential equations. Hence, result reliability problems arise in the course of determining the vibration level of such accurate calibration devices by calculating methods. Therefore, to find out possible sources of uncertainties and errors in the course of creating tools of such high-end technologies one should be guided by experimental tests despite the fact of their expensive costs.

## Conclusions

1. It has been found out that low-frequency vibrations are capable of affecting the accuracy of reading while the carriage with a microscope are moving.
2. Spectral amplitude values of the measured vibrations fluctuate from 0.02 to 0.04  $\mu\text{m}$ .
3. Preventive means of reducing vibrations should be designed.

## References

1. **Thalmann R.** A new High Precision Length Measuring Machine, Progress in Precision Engineering and Nanotechnology, Proceedings of the 9-IPES/UME4, Braunschweig, Germany. 1997. Vol.1. P. 112-115.
2. **Frank C.** Demarest, high-resolution, high-speed, low data age uncertainty, heterodyne displacement measuring interferometer electronics, Meas. Sci. Technol. 1998. Vol.9. P.1024-1030.

3. **Beers J. S. and Penzes W. B.** The NIST length scale interferometer. J. Res. Natl. Inst. Stand. Technol. 1999. Vol.104. P. 225.
4. Nano4: 1D gratings, WGDM-7: Preliminary comparison on nanometrology according to the rules of CCL key comparisons Final report, Draft B, Wabern. 30. November 2000. P. 34.
5. Vibrations in engineering. Reference book in 6 volumes. Vol. 1/ Edited by V.V. Bolotin, M.: Machine-building. 1978. P.352.

Received 04 04 2006

DOI: 10.5755/j01.u.59.2.16979