

Assessment of passenger car driveability with use of two axis accelerometer mounted on car body

S. Brol, J. Mamala

Technical University of Opole, Chair of Road and Agricultural Vehicles

Opole 45-271, ul Mikolajczyka 5, Poland, Phone: +048 77 400600,0 E-mail:mamala@po.opole.pl.

Abstract

In this paper an assessment of passenger car drivability with use of two axis accelerometer mounted on car body is shown. The car body acceleration measurement was analyzed in four areas: sensor accuracy, accelerometer and working engine related noises, sensor coordinate system reorientation during instantaneous acceleration or braking and disturbances caused by the road irregularities. Simulations and experimental results proved that car acceleration measurement is disturbed by the car suspension reaction when it accelerating or braking and road irregularities.

Introduction

Till today many devices have been constructed with ability to measure or estimate car drivability parameters like engine power and torque. There are many solutions based on many concepts. The most popular and relatively cheap way is to access the OBD system and retrieve values of the actual parameters like engine load, car speed etc. Basing on these values the power and torque are calculated [2, 4]. Flaw of this solution is that the car must have OBD system and the device must be able to communicate with it. It demand from the device, if it should be fully portable, to be equipped with four interfaces: ISO, PWM, VPW and CAN which complicates the hardware and software. Another problem is that the OBD system is not designed for real time data transmission.

More simple, portable and dedicated for all cars or trucks solution is to utilize only multi axis accelerometer with microprocessor system. There are many applications for so designed system: assessment of power train and braking system, braking efficiency, engine performance etc [6, 7].

If any assessment is to be make with this kind of measurement system then on-road test must be performed. Typically it consist of acceleration with fully depressed acceleration pedal phase and free run to stop or full braking. If the device is accelerometer based and mounted in car body then during the road test many factors influences on measured acceleration. This is a primary parameter which must be measured properly, if credible test results should be achieved [4, 5].

Methods of analysis

Assessing car drivability with use of portable accelerometer based device demand on-road test. Mounting it in a car must be done without any changes in cockpit construction. This assumption reduces the possibilities of mounting points to windshields, windows and floor area. Considering car as a body with ideal stiff suspension moving on flat surface tangential oriented to the gravity direction the acceleration measurement is simple. Only one think is to do – to set the orientation one

of the sensor measurement direction to be perpendicular to the movement direction. The accelerations measured under the conditions are equal to the real accelerations acting on the car. In a real car moving on a real road acceleration measured and real acting are not equal. There are many significant factors influents on this situation like road irregularities, car suspension construction and stiffness, wheel base, wheel track. The accuracy of acceleration measurement will be considered as the difference between real and measured car body acceleration in three areas:

1. Sensor accuracy.
2. Accelerometer and working engine related noises.
3. Sensor coordinate system reorientation during instantaneous acceleration or braking.
4. Disturbances caused by the road irregularities.

Sensor accuracy

Measurements of car acceleration was made with use of dual axis accelerometer. The low-cost analogue and digital output Analog Devices ADXL202 sensor were used. (Fig. 1).

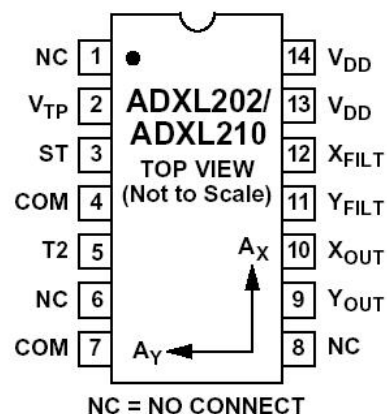

Fig. 1. Accelerometer used to measure car acceleration

The ADXL202 acceleration range is $\pm 17.62\text{m/s}^2$ and output signals are analog, ranging from 0V to 5V, and

digital PWM. It can measure accelerations or tilt because it is earth acceleration sensible.

Accelerometer and working engine related noises

Accelerometer output signals are not noise free. In general in all low-cost accelerometers the output signal contain a gaussian noise.

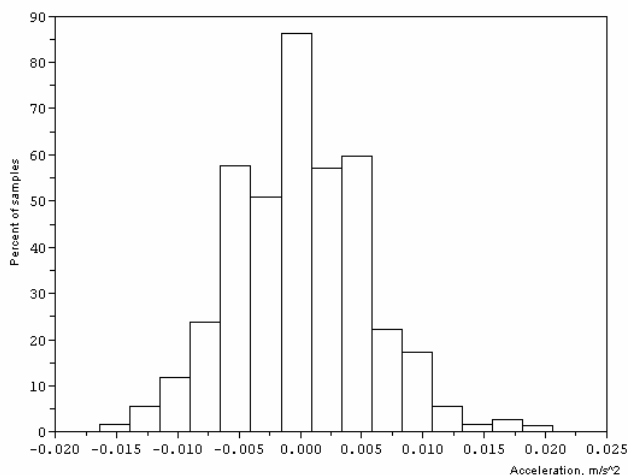

a

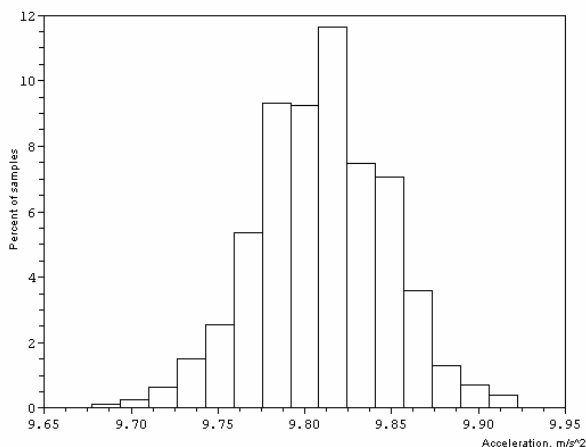

b

Fig. 2. Accelerometer output signal histograms when acceleration $a=0 \text{ m/s}^2$ a) and 9.81 m/s^2 b) was applied

The output noise is varying with the measurement bandwidth. Reduction of bandwidth will improve the signal to noise ratio and the resolution. The output noise is proportional to the square root of the measurement bandwidth. The noise RMS is also depended on acceleration acting on the sensor. As shown in Fig. 2, it is the lowest for acceleration $a=0 \text{ m/s}^2$ and become greater when acceleration increases.

For $a = 0 \text{ m/s}^2$ the peak-to-peak ratio is equal to 0.04 m/s^2 (Fig 2a) and for $a=9.81 \text{ m/s}^2 - 0.28 \text{ m/s}^2$ (Fig 2b). The peak-to-peak value approximately defines the worst case resolution of the measurement. Measurement reduction appending to the peak-to-peak value in this kind of sensors is troublesome because of peak-to-peak value changes in function of acceleration.

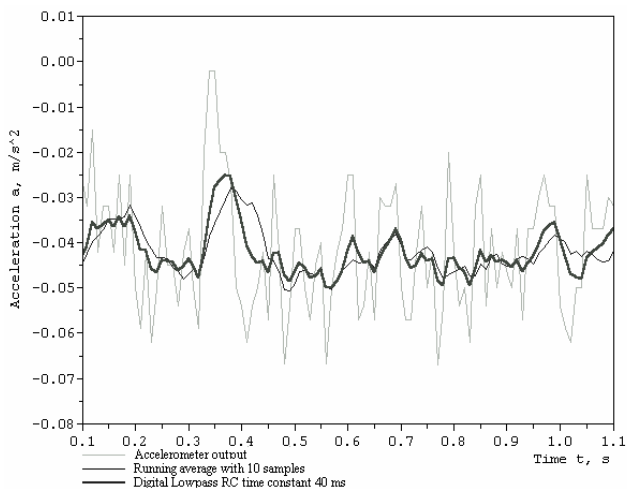

Fig. 3. Original, moving average with 10 samples and digital RC filtered accelerometer output signal when acceleration $a=0 \text{ m/s}^2$ was applied

The most important problem is how to smooth the output signal so, that it still be adequate to dynamic changes in acceleration. Two digital lowpass filters were tested to asses which one better remove the noise: running average and RC. Filters parameters was chosen so, that the signal amplitude reduction was for both the same and was equal to 50% of peak-to-peak value. The best performance was achieved with use of RC filter (Fig. 3.). The output of RC filter is more smooth then the original signal and gives more fast response then the running average which generates phase shift dependent on number of samples used to average original signal. Unfortunately no of examined filters was able to remove the Gaussian property of output signal and reduce the peak-to-peak value to zero. Alternative method to reduce the noise is to lower measurement resolution to 0.05 m/s^2 witch is lower then peak-to-peak value when acceleration $a=0 \text{ m/s}^2$ applied.

The sensor noises are relatively low in compare to signal changes when car engine is running. The noise is engine type (gasoline or diesel), rotation speed, number of cylinders, engine suspension, and unbalanced masses depended [3].

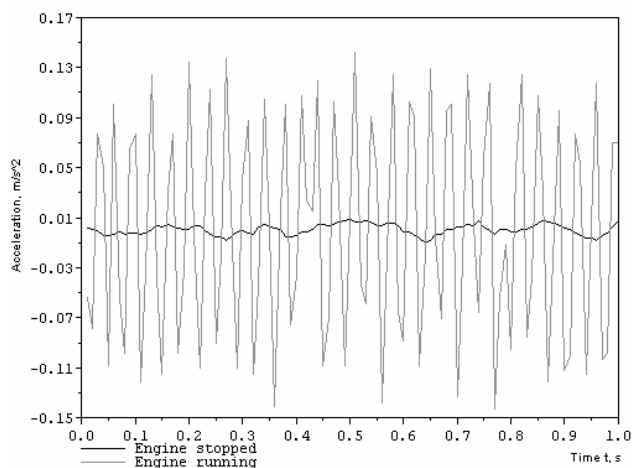

Fig. 4. Comparison of accelerometer output signal when engine stopped and idling. The test was made on Citroen BX car with four stroke, four cylinders 1.9 dcm^3 diesel engine. Engine was idling at 900 RPM

As shown on Fig. 4. the engine indicated peak-to- peak value is about 6 times greater then sensor when $a=0 \text{ m/s}^2$. It is clear to see that if the engine is stabile idling it produces stationary sinusoidal-like wave. Generally the gasoline engines produces lower amplitudes then the diesels. In this case, the worst in all test results, the acceleration amplitude (0.24 m/s^2) is close to peak-to-peak value of accelerometer when only 9.81 m/s^2 acceleration is applied (0.28 m/s^2). When this four stroke, four cylinders engine is idling, at 900 RPM (15 rev/s) the wave frequency is 30Hz. It means that this frequency is combustion depended because the combustion process happens two times per one crankshaft revolution.

The acceleration measurement sample rate was set to 100 Hz, so only three samples are measured for one combustion. When the engine increase their rotational speed the combustion frequency will also increase. If the combustion frequency will be greater then Nyquist frequency (50 Hz at 1500 RPM) then it will lead to aliasing phenomena which can deliver additional uncorrelated wave to the measured signal.

Sensor coordinate system reorientation during instantaneous acceleration or braking

It was made an assumption, that the sensor will be in initial position oriented so, that one of its measurement axis will be parallel to the car movement direction and the second to gravity vector. It is important to notice, that in all considered sensors the measurement axis should be oriented so, that the measured acceleration will be in opposite to axis sense. As shown in Fig. 5 the sensor coordinate system is bound with car body and the global with earth acceleration and movement direction.

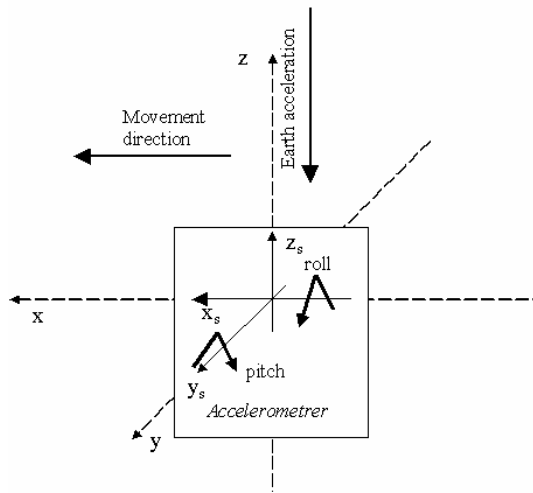

Fig. 5. Global and sensor associated coordinate systems

As mentioned before, the device was projected so, that it should be able to measure car performance on on-road test with use of accelerometer mounted on car body. The first part of on-road test is car acceleration phase. During it the car body changes the pitch angle relative to road surface.

When the car accelerate its body and associated with it sensor coordinate system changes position and pitch angle relative to global coordinate system. The acceleration of

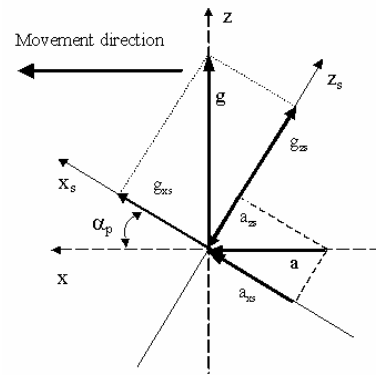

Fig. 6. Sensor coordinate system reorientation when car is accelerating

car is bounded with global coordinate system but the measured acceleration with the sensor. If pitch angle is non zero between them, then the measured acceleration is equal to projection of all accelerations on measurement axis like shown on figure 6. The sense of earth acceleration vector is pointing in opposite direction then typically showed (like on Fig. 5). It is so because the inner sensor element decelerate while the housing is accelerating. In fact it reacts on deceleration relative to housing so the earth acceleration vector sense must be showed like on Fig. 6 if the accelerations projections should be properly described.

The measured accelerations on accelerometer axis are as follows:

$$\begin{aligned}
 \sum a_{x_s} &= a_{x_s} + g_{x_s} \\
 \sum a_{z_s} &= g_{z_s} + a_{z_s} \\
 \sum a_{x_s} &= a \cos(\alpha_p) + g \sin(\alpha_p) \\
 \sum a_{z_s} &= g \cos(\alpha_p) - a \sin(\alpha_p)
 \end{aligned}
 \tag{1}$$

where: a – real car acceleration, a_{x_s} – car acceleration projection on x_s axis, a_{z_s} – car acceleration projection on z_s axis, α_p – car body pitch angle between sensor and global coordinate system, g – earth acceleration, $g=9.81 \text{ m/s}^2$, g_{x_s} – earth acceleration projection on x_s axis, g_{z_s} – earth acceleration projection on z_s axis.

To assess how the pitch angle influences on measured accelerations on x_s and z_s a simulation was performed. It was made an assumption, that the car acceleration is raging form $a=-10 \text{ m/s}^2$ to $a=10 \text{ m/s}^2$ and the pitch angle from $\alpha_p=-10$ to $\alpha_p=10$ degrees. The results as a difference between measured on x_s and z_s axis (a_{x_s} and a_{z_s}) and forward car acceleration a according to Eq. 1 are shown.

As shown on Fig. 7 the difference between measured on x_s axis and real forward acceleration for pitch angle $\alpha_p=-10$ degrees is equal to -1.52 m/s^2 and for $\alpha_p=10$ degrees is 1.7 m/s^2 . The difference is also forward acceleration dependent and increases with pitch angle.

The changes of acceleration difference value in z_s measurement direction are also pitch and forward acceleration dependent (Fig 8). They are a little bit lower then in x_s direction. The greatest value is 1.27 m/s^2 and the lowest 1.27 m/s^2 . In generally the measured acceleration is greater when the char is accelerating and lower when it braking. It is so because reorientation of sensor based

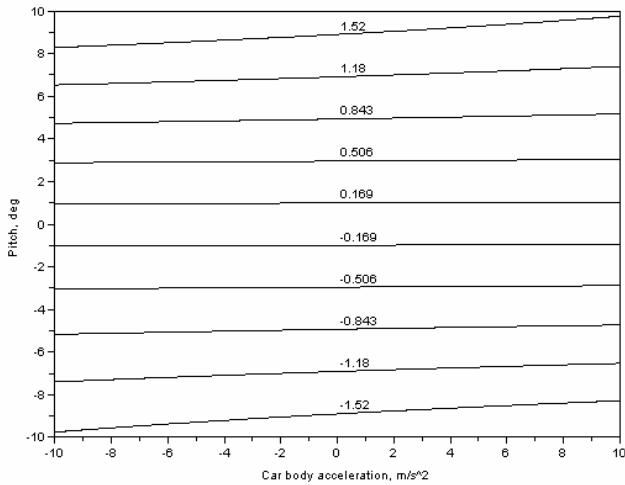

Fig. 7. Simulated acceleration difference ($a_{x_s} - a$) between measured on x_s axis and real car body acceleration as a function of car body acceleration and pitch angle

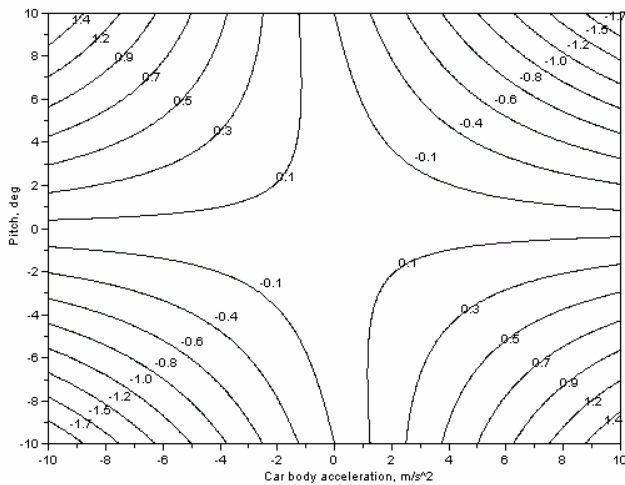

Fig. 8. Simulated acceleration difference ($a_{z_s} - a$) between measured on z_s axis and real car body acceleration as a function of car body acceleration and pitch angle

coordinate occurs and the projection of gravity acceleration decides about measurement acceleration value.

As shown before the pitch angle change cause a significant acceleration error specially measured on car longitudinal axis. A simulation was performed to check if it is a possibility to determine momentary pitch angle from accelerations measured on x_s and z_s axis.

For this purpose a graph was made where the measured accelerations distribution on x_s and z_s axis are combined.

Simulation results showing (Fig 9), that for pairs of accelerations measured in x_s and z_s axis are more than one combination of car body accelerations and pitch angles. For example if $a_{x_s} = 0.6 \text{ m/s}^2$ and $a_{z_s} = 9.8 \text{ m/s}^2$ (see the shaded circles on Fig. 9) the car body acceleration could be -0.1 m/s^2 or 0.75 m/s^2 and the pitch angle adequately 0.1 and 6 degrees. It leads to conclusion that the determination of car body pitch angle can not be done with use only measured by accelerometer values.

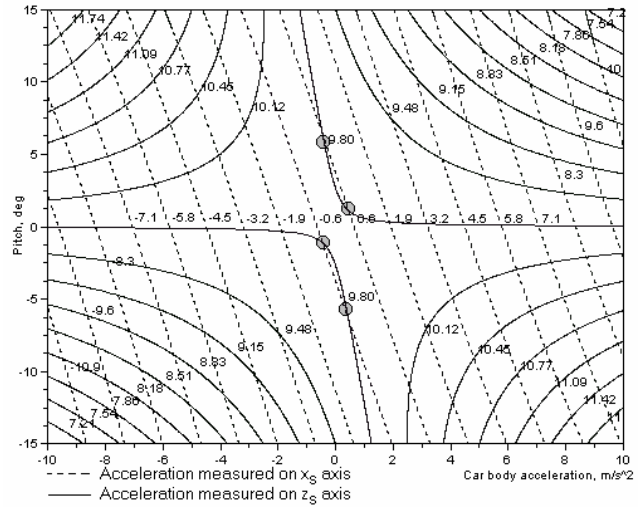

Fig. 9. Simulated acceleration measured on x_s and z_s axis and real car body acceleration as a function of car body acceleration and pitch angle

The simulation results were verified on on-road tests where the Fiat Punto was used. It was chosen because its wheel base equal to 2510 mm. This relatively short wheel base could cause a significant car body pitch change while it accelerate or decelerate. Fig. 10 shows on-road test results when accelerometer output from x_s axis are compared to forward acceleration compared with acceleration calculated from speedometer signal. There is an offset between signals in acceleration and deceleration phase. The acceleration measured by accelerometer is greater when car is accelerating and lower when braking in compare to speed signal derivative.

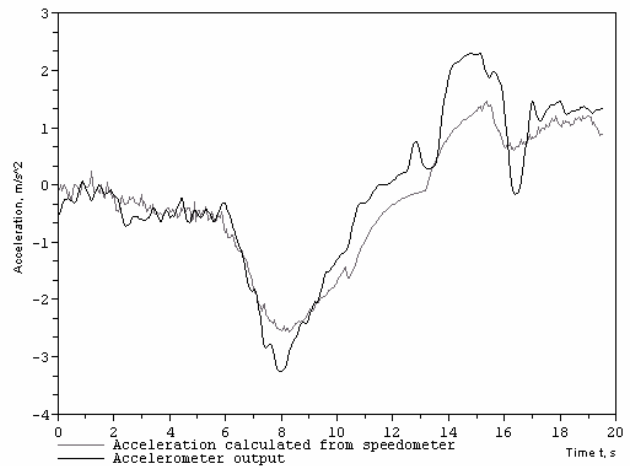

Fig. 10. Accelerometer output from x_s axis and acceleration calculated from speedometer signal. Data acquired on on-road test with use of Fiat Punto

In general the offset value is varying and is car suspension stiffness, wheel base, car mass and driving force applied depended. The greatest registered difference on this road test was 0.9 m/s^2 when the car is accelerating with 1.5 m/s^2 . Compared with the difference distribution map on fig. 7 the pitch angle in moment of maximum acceleration was 4 degrees. The acceleration calculated from speedometer signal is smoother then from

accelerometer. It is so, because the accelerometer signal is disturbed by additional multi axial accelerations causing by the road irregularities and engine noise.

Disturbances caused by the road irregularities

When the car's wheels are moving on the road its irregularities indicate accelerations which can be different in its value and direction for every wheel. They acting through suspension on car body and, causing lateral and longitudinal tilt ratio changes [1]. Road irregularities dependent accelerations and both tilt ratio changes can disturb the acceleration measurement because they generate an additional accelerations which value is road surface quality and sensor position in cockpit depended.

Conclusions

The accelerometer output noise floor is bandwidth and acceleration depended. If any microprocessor based acceleration system will be projected the filtering method should be considered. The best performance was achieved with use of RC filter. Its hardware realization will reduce processor load, but will add a time constant to filtered signal. The A/D measurement resolution should be peak-to-peak value of filtered signal related. Lowering the measurement resolution will reduce the noise but also the system accuracy. It should be a optimal solution received which will get into account the assumed accelerations range, system accuracy and response to acceleration value changes.

The engine noise is hard to vanish because it is, beside others, engine rotational speed related. Reduction of engine noise could be achieved only when RPM signal will be delivered to the system.

The car acceleration or braking is related to car body pitch and pitch ratio changes witch causing a difference between measured and forward car acceleration. It is impossible to correct this pitch based only on measured signals. If pitch compensation should be made the characteristic of suspension reaction on acceleration must be made or pitch angle must be measured.

Acknowledgements

The authors wishes to thank the Polish State Committee for Scientific Research which supported this work in years 2005 - 2008.

References

1. **Duym S. and Reybrouck K.** Physical Characterization of Nonlinear Shock Absorber Dynamics. *European Journal Mech. Eng.* Vol. 43. No. 4. P. 181-188.
2. **Jantos J.** Control of the Transmission Ratio Derivative in Passenger Car Powertrain with CVT, *SAE Transactions. Journal of Passenger Cars – Mechanical Systems*, SAE. 2001. P.1277-1284.
3. **Mamala J., Jantos J.** Sterowanie stopniem zasilania silnika podczas przyspieszania samochodu. *Teka Komisji Naukowo-Problemovej Motoryzacji PAN* 2003, Zeszyt 26-27. P. 265-270.
4. **Serrarens A. F. A., Veldpaus F. E.** Dynamic modelling for dimensioning and control of a flywheel assisted driveline, *Vehicle Systems Technology for the Next Century*. Spanish Society of Automotive Engineers STA, Barcelona. 1999. P. 234-247.
5. **Silka W.** *Teoria ruchu samochodu*. WNT Warszawa. 2002.
6. **Constancis P., Leorat F.** Global Powertrain Control. *FISITA'98*. 1998. No. F98P506.
7. **Wenguang G. Wang, Reda M. Bata.** Transient Response in a Dynamometer Power Absorption System. *SAE 920252*. 1992. P. 42-50.

Received 04 04 2006

DOI: 10.5755/j01.u.59.2.16980