

Quasi-electrostatic converters in materials' quality control

S. Sakalauskas, R. Pūras, Z. Vaitonis

Vilnius University, Saulėtekio al. 9-III, LT-10222 Vilnius, Lithuania,

E-mail: stanislavas.sakalauskas@ff.vu.lt

Abstract

The action of electrostatic converters is based on well known in physics phenomenon of electrostatic induction. A construction of converters may be various depending on properties of materials (structures) under investigation and on control or measurement objectives. Schematic diagrams of vibrating probe converter and capacity converter with linear varying voltage pulse source are presented in the paper and the main characteristics of converters are analyzed with consideration measurement timescale. Some experimental results are presented and discussed.

Keywords: nondestructive measurement technique, capacity converter, surface electric potential, electron work function.

Introduction

Various materials – metals, semiconductors, polymers – are used for fabrication and investigation of semiconductor electronics components, MEMS and nanostructures. Often it is necessary to achieve that the same material in special localized site should have intended bulk or surface properties significantly different from properties in other regions. Broad facilities of modern technologies enable realize these aims, but to guarantee the qualitative characteristics of structures it is necessary perform non-destructive control of parameters between operations and a final control.

Much information in control of materials' surface properties can give the value of electron work function and its dependence on various factors. Several methods, such as thermoelectronic, photoelectric, parametric capacity converters, are used to determine electron work function. The last – vibrating Kelvin–Zisman probe – method is most approved today and it is characterized by highest sensitivity and best spatial resolution in surface physics [1, 2].

Various specifications are expected to polymers as other dielectric materials: high surface resistance, high volume resistance, high breakdown voltage, low dielectric loss and so on. Mentioned parameters may be controlled and measured in particularly small areas by using linear voltage source together with low input capacitance voltage amplifier [3].

The aim of this work was to analyze threshold possibilities in materials' quality control of both above mentioned quasi-electrostatic converters and present some characteristic experimental results.

Measuring device with parametric capacity converter

Characterization of this measuring device operation is given in [2], therefore we will analyze only the main its characteristics. Schematic diagram of surface potential measuring device is shown in Fig. 1. Vibrating probe 3 with sample 2 forms periodically varying capacity

$$C(t) = C_0 \left[1 + \left(\frac{\Delta C}{C_0} \right) \cos \omega_1 t \right]^{-1}.$$

The electric charge of capacity is proportional to probe's and sample's electron work functions difference $Q(t) = C(t)(A_3 - A_2)q^{-1}$, here q – electron charge. If $RC_0\omega_1 \gg 1$, we will have voltage of frequency ω_1 . The voltage amplitude is proportional to electron work function of sample under investigation as the surface of vibrating probe is passivated and its electron work function is stable and known. This signal is amplified by band-pass amplifier 10, detected by lock-in amplifier 11, passed to recording equipment and to adder 12. Installed 100 percent negative feedback significantly improves parameters of measuring device. Signal of high frequency ω_2 and calibrated amplitude signal (from generator 14, $\omega_2 \gg \omega_1$) are also attached to adder 12. According to this signal the fixed distance between probe tip and sample surface is maintained. Thus output voltage $U_2(z, x, y)$ contains information about sample's surface roughness.

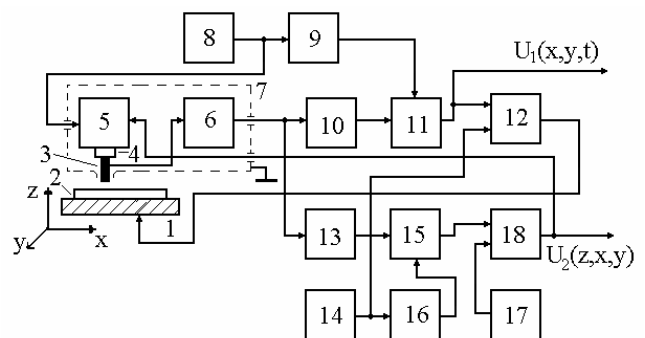

Fig. 1. Schematic diagram of surface potential measuring device: 1 – coordinate plate, 2 – sample, 3 – measuring probe, 4 – insulator, 5 – block of vibrations and shifts, 6 – high input resistance voltage amplifier, 7 – shield of capacitance converter, 8, 14 – generators, 10, 13 – selective amplifiers, 9, 16 – phase converters, 11, 15 – lock-in amplifiers, 12, 18 – adders, and 17 – source of threshold voltage

The main output voltage $U_1(x, y, t)$ is related to sample's electron work function A_2 (or in unambiguous way related to surface potential ϕ_2) by dependence:

$$-U_1(x, y, t) = \frac{A_3 - A_2(x, y, t)}{q} \cdot \frac{K_\Sigma(t)}{1 + K_\Sigma(t)} =$$

$$[\phi_3 - \phi_2(x, y, t)] \frac{K_\Sigma(t)}{1 + K_\Sigma(t)}, \quad (1)$$

here $K_\Sigma(t)$ is the product of transmission coefficients: capacity converter, high input resistance amplifier, band-pass amplifier, and lock-in amplifier. Usually it is settled to be $K_\Sigma(t) = 10^3 \dots 10^4$, when transient process is terminated. Output voltage U_1 associated to surface electric potential by relation:

$$U_1 = -\phi_3 + \phi_2. \quad (2)$$

Limiting sensitivity of measuring device depends on many factors, but mainly on vibrating probe diameter, vibration amplitude, distance to sample surface and equivalent time constant of measuring device. In optimal mode, when the diameter of probe is 10 μm and time constant is 5 s, a limiting sensitivity reaches $(100 \pm 10) \mu\text{V}$.

Spatial resolution of measuring device may be estimated by diameter of the area from which information is collected:

$$D \approx d \sqrt{1 + 4h^2/d^2}, \quad (3)$$

here d is the diameter of vibrating probe, h is the distance between probe and sample's surface. Incorporated maintenance control of distance h warrants practically constant spatial resolution and it may be measured up to 1000 points in distance of 1 nm (when the vibrating probe diameter is close, but less than 1 μm).

Now we will discuss some experimental results. Nickel and its alloys are often used in electronics for various purposes. The value of work function is important in formation metal-oxide-semiconductor structures because it effectively changes the value of structure's bias voltage by varying metal's work function [5]. We will present one possible method to change material work function. The results presented in Fig.2 show the influence of laser treatment on nickel and molybdenum alloy's work function due to structural changes created by laser.

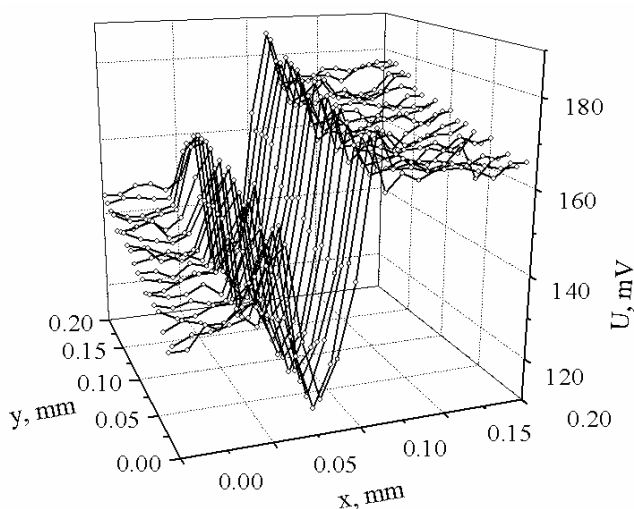

Fig.2. Distribution of the surface electric potential of nickel – molybdenum (25...27)% alloy plate acted by laser treatment (the right area)

In fabrication of planar high voltage diodes it is very important to warrant linear distribution of voltage in the surface region p-n junction since semiconductor's surface properties may be alternated by interaction with environment. Diode of the larger p-n junction area is more influenced by environment according to results presented in Fig. 3. The difference between the values of surface electric potential in the dark and illuminated surface is greater for large area p-n junction; also the greater surface electric potential non-uniformities are characteristic to this junction.

Properties of electrical contact are very important in semiconductor electronics, the contact must be ohmic and should have good adhesion to semiconductor. GaAs is one of materials whom to form the qualitative contacts is complicated [6]. The results presented in Fig. 4 show how

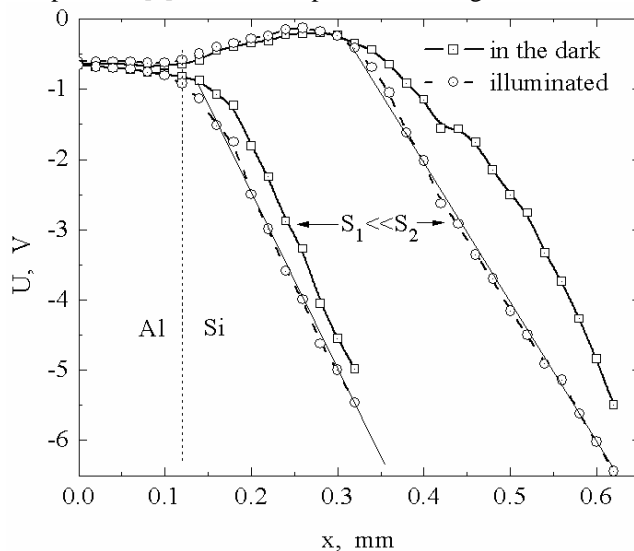

Fig.3. Distribution of surface electric potential in region of p-n junction of planar high voltage diode. S_1 and S_2 – area of junctions

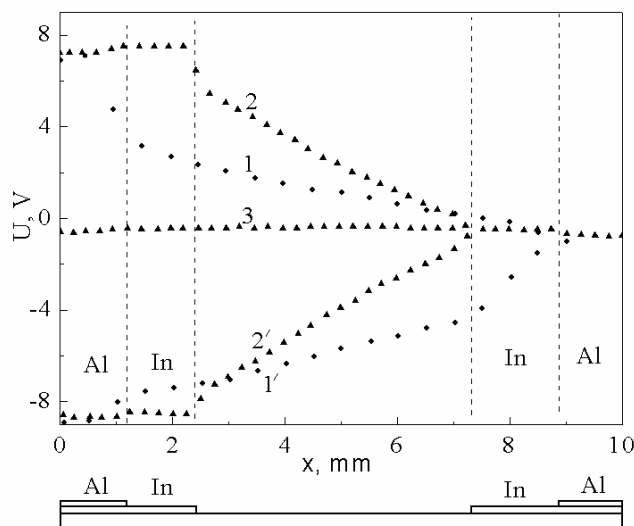

Fig.4. Distribution of surface electric potential along semi-insulating GaAs when external voltage source is connected. 1, 1' correspond the case when In contacts are formed by thermal treatment, 2, 2' - contacts are formed by laser deposition of In and 3 – distribution without voltage source. The structure of contacts is shown schematically in upper side of figure

effectively and rapidly electrical properties of contacts may be determined according distribution of the surface electric potential when external voltage source is connected to sample.

Experimental results presented previously show the possibilities of parametric capacity converters to control surface (sometimes and bulk) properties of various materials without mechanical contact to sample, the process of control may be computer assisted.

Capacity converter with linear varying voltage pulse source

The principle electric diagram of the measuring device with linear varying voltage pulse source is presented in Fig. 5. If the capacity C of sample is constant, output voltage U is connected to this capacity by relation:

$$C = U \left\{ aR_1 \left[1 - \exp\left(-\frac{t}{\tau}\right) \right] \right\}^{-1}, \quad (4)$$

here $\tau = R_1(C + C_1)$, consequently it is possible to change transient period by choosing resistance R_1 , but reducing R_1 we will reduce sensitivity of converter. Relationship (4) may be used to control linearity voltage U .

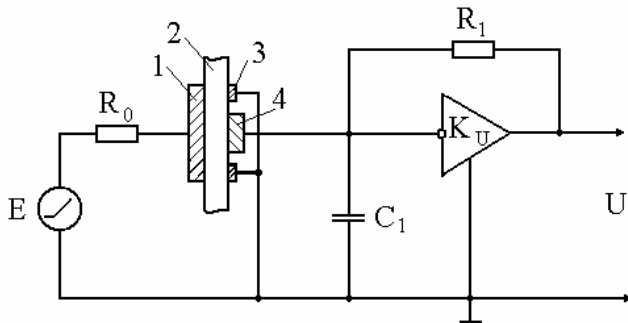

Fig. 5. E – source of linear varying voltage and R_0 its internal resistance, 1 – high voltage electrode, 2 – sample, 3 – protective electrode, 4 – measuring electrode, R_1 , C_1 – load resistance and capacitance, C_2 – capacitance in a circuit of positive feedback, which partially compensates influence of capacitance C_1

Capacity of real sample (dielectric coating or film, MOS structure) depends on voltage, also capacity is shunted by leak resistance which can depend on voltage additionally. Both capacity components can be controlled and measured by this converter, for this the rate of voltage variation a must be changed. By changing rate of voltage variation the current component, determined by capacity C , also will change. Current component of leak resistance will depend on instantaneous value of voltage U :

$$\begin{cases} I_{1m} = a_1 C_m + \frac{U_m}{R_m} = a_m C_m + I_{0m}, \\ I_{2n} = a_2 C_m + \frac{U_m}{R_m} = a_2 C_m + I_{0m}, \end{cases} \quad (5)$$

here U_m instantaneous voltage of source E , C_m , R_m – instantaneous capacity and resistance values when voltage is U_m , I_{1m} and I_{2m} – instantaneous current values corresponding to distinct values of a_1 and a_2 . It is possible to deduce values of C_m and I_{0m} also dependencies $C(E)$ and $I_0(E)$ from Eq.5.

Experimental results are presented in Fig. 6. Capacity (whom corresponds the voltage U) of SiO_2 layer practically doesn't vary. Further increase of electric field strength E_D produces layer breakdown. Variation capacity of junction $\text{Al-SiO}_2\text{-Si}$ is more complicated, here influence of semiconductor capacity must be estimated. The dependency shown by curve 3 in Fig. 6 is characteristic to various high voltage junctions switched in backward direction. In the region of low value linear varying voltage the capacity component of current dominates. When voltage increase, conduction current must be estimated together with capacity current as evaluated in Eq.5*.

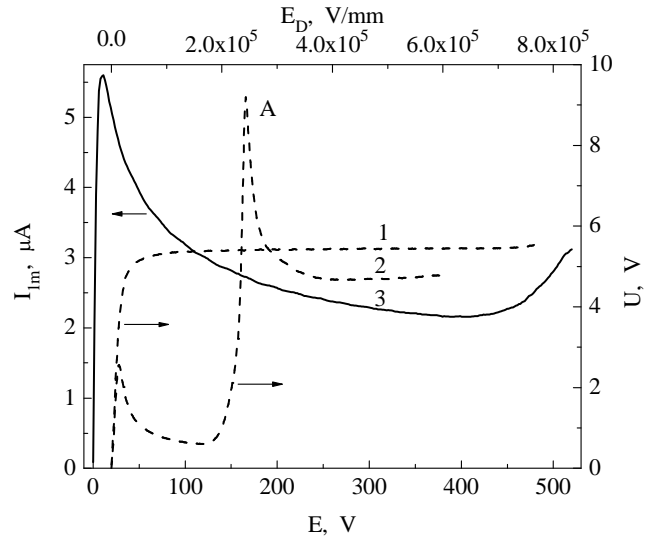

Fig. 6. Capacity dependencies of SiO_2 layer (1) and Al-SiO_2 structure on electric field strength E_D . Peak A corresponds to inversion layer formation in semiconductor. Curve 3 represents p-n junction's current dependency on linear varying voltage E value

Conclusions

Analysis main characteristics of two type quasi-electrostatic converter and presented experimental results suggest:

- for material surface properties investigation and for structures contact properties investigation the most suitable is vibrating probe converter;
- capacity converter with linear voltage source successfully may be used for dielectric and polymer films properties investigation, it is characterized by high operation speed.

References

1. Lüth H. Surfaces and interfaces of solid materials. Berlin: Springer. 1997. P. 556.
2. Sakalauskas S. and Sodeika A. Automatized measuring instrument of the surface electric potential and potential's distribution. Rev. Sci. Instrum. 1998. Vol. 69. P. 466-468.
3. Montrimas E., Sakalauskas S., Pažera A., Lozovski T., Tamošiūnas S. Influence of slow surface levels to electrical properties of MOS structures and method of investigation. Electron technology. 1994. Vol. 27. P. 49-55.

* Components of measurement uncertainties wasn't discuss here, as they depends on converter type and sample peculiarities.

4. **Montrimas E., Pažėra A. and Sakalauskas S.** Effective estimation method of basic parameters of MOS structures. Electronics and Electrical Engineering. 2000. No 6(29). P. 18-21. (in Lithuanian).
5. **Kahaam K.** Semiconductor devices. Prentice Hall, New Jersey. 1998. P. 480.
6. **Kazlauskienė V., Kažukauskas V., Miškinis J., Petravičius A., Pūras R., Sakalauskas S., Sinius J., Vaitkus J.-V. and Žindulis A.** Formation of ohmic contacts on semi-insulating GaAs by laser deposition of In Semiconductors. 2004. Vol. 38. P. 78-81.

S. Sakalauskas, R. Pūras, Z. Vaitonis

Kvazielektrstatinių keitiklių taikymas medžiagų kokybės kontrolei

Reziumė

Elektrostatinių keitiklių veikimo principas grindžiamas fizikoje gerai žinomu elektrostatinės indukcijos reiškiniu. Priklausomai nuo tikrinamų medžiagų ar darinių savybių, kontrolės ar matavimo tikslų elektrostatinių keitiklių konstrukcijos gali būti labai įvairios. Čia aptariamos parametrinių talpinių keitiklių (virpamojo elektrodo keitiklis ir keitiklis su tiesiškai kintančios įtampos impulsų šaltiniu) struktūrinės schemos, svarbesnės charakteristikos ir panaudojimo galimybės, ypatingą dėmesį kreipiant į kontrolės ir matavimų operatyvumą, pateikiami eksperimentiniai rezultatai.

Pateikta spaudai 2006 03 30

DOI: 10.5755/j01.u.59.2.16986