

The influence of technology and atmosphere on the properties of fiber-reinforced polymer-matrix composite materials

I. Chatys, R. Chatys

Kielce University of Technology

Al.1000-lecia P.P. 7, 25-314, Kielce, Poland, Phone:(0048-41) 3424507, Fax. (0048-41) 3424517,

E-mail: chatys@tu.kielce.pl

Abstract

The paper focuses on the influence of technology and atmosphere on the strength of fiberglass-reinforced polymer-matrix composite materials. Two technologies were analyzed: RIM (Resin Infusion Molding) and RTM (Resin Transfer Molding). The strength was modeled for different operating conditions and different fiber orientations. Other physical and mechanical properties of a polymer-matrix composite were also studied.

Keywords: polymer composite, infusion, process, strength, modeling

Formation of polymer-matrix composites

Laminates and composites can be produced in a number of ways. One of the most common technologies today is resin infusion molding, which consists in drawing resin into a mold under vacuum. If the process is automated, laminates do not vary much in quality, the rate of element fabrication is high, detail precision is increased, and the manufacturing cost is low. Unlike wet lamination, infusion is an environmentally friendly process. The volatile emission is negligible, because the fiber wetting occurs in the vacuum bag. Vacuum infusion, however, is different from vacuum bagging; it requires placing a dry reinforcement in a mold, and then drawing resin into it under vacuum conditions.

The RTM technology, which involves injection of liquid resin under pressure is also a popular method of composite formation [1]. It is considered a better alternative than the traditional manual methods of polymer-matrix plastic formation in open molds.

Resin infusion molding

The infusion molding process [2] requires lining a mold with a dry fabric reinforcement, which is easy to cut and fit. This delimitation fabric along with a special net responsible for resin distribution forms a textured structure of the laminate surface, which makes the bonding of layers more effective. Special low-viscosity *Tool fusion* resin is supplied from a vessel to a mold through the net channels. The net needs to suit the resin flow rate and assure uniform distribution across the mold. The low-viscosity resins used in the infusion molding technology are characterized by high convertibility; they do not need cool storing or transporting.

When applying the *tool fusion* resins, it is possible to form composite materials with no time limits. The lamination can be performed at an arbitrary speed. Moreover, the weight of the laminate can be reduced even by 70 %, compared to that in traditional methods, without changing the operating conditions. The *Tool fusion* resins, which are cured at a room temperature do not lose their

strength properties after post-curing at the temperature of approximately of 190°C.

Table 1. Epoxy resins used in modern technologies (Airtech patent [3])

Araldit resins and hardeners used for manual lamination	Life cycle 100g at 23°C [min]	Gelling time 80 °C [min]	Viscosity 25 °C [MPa]	Typical curing process [h/°C]
LY 3505/XB 3403	600÷720	36÷48	300÷400	4/60 + 6/80
LY 3505/XB 3404	80÷100	11÷18	550÷800	4/60 + 6/80
LY 3505/XB 3405	26÷36	5÷11	1000÷1200	4/60 + 6/80
LY 1556 SP/XB 461	320÷360	30÷34	800÷1100	4/60 + 6/80
LY 1556 SP/XB3405	40÷50	6÷9	1500÷1800	4/60 + 6/80

It is necessary to plan precisely the orientation of channels through which resin is supplied or of spiral pipes (strip springs) around the tool surface to assure proper application of vacuum to form the laminate. The spiral pipes make the resin flow smoothly with no traces left. The strip springs can be used repeatedly. The dry laminate with the resin supply system is covered with a special foil, which acts as a vacuum bag. The mold cavity is lined with a multilayer polyamide foil. If a tool is small, the foil can be placed inside the vacuum bag instead. The next step is to connect the overflow vessel with the channels supplying the liquid resin. Before vacuum is applied, it is recommended to check the system leak tightness. A leakage may greatly affect the process of lamination [4]. Pressure loss and air trapped between the layers cause that the laminate quality is lower. The system under consideration does not require autoclaving, and, as a result, energy costs of element production are reduced. As resin curing may occur at low temperatures, it is possible to apply cheaper materials to make master molds. Expensive tool blocks are substituted by cheaper model ones or by foam to be cut with numerically controlled machine tools. The tool costs are reduced and the element is easier to reverse engineer. Applying handmade molds or coated

chipboard results in additional savings. It is also possible to produce more molds in various shapes.

In the resin infusion molding technology, it is essential to properly select the fiber (glass or carbon) responsible for the in-process wetting and the penetration through the resin mixture. The costs of the composite formation using this technology are similar to those of manual lamination. The properties of composites resemble those of epoxy prepares. We obtain a better quality laminate similar to that obtained with the prepare method using the autoclave process. However, the amount of resin used is smaller, there is minimum contact with resin and lower labor costs [5].

Resin transfer molding

Formation of composite elements using the Resin Transfer Molding is now one of the most common manufacturing methods (Fig. 1), more popular than the traditional methods employing open molds, such as manual lamination or resin spray with fibers cut into strands.

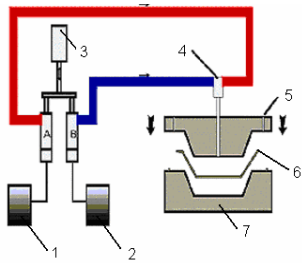

Fig. 1. RTM facility: 1 – resin; 2 – hardener; 3 – pump; 4 – mixing head; 5 – vent; 6 – mold

The whole RTM process takes place in a closed mold (Fig. 2), where both sides of the element – the inside and outside walls – are smooth. The RTM facility is equipped with a feeder, a pump and a mixing head. The feeding and mixing processes are fully automated.

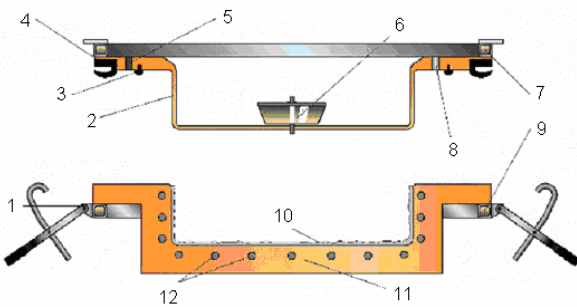

Fig. 2. Closed mold used in the RTM method: 1 – closing clamp; 2 – flexible top part of the mold; 3 – inner seal; 4 – outer vacuum seal; 5 – peripheral vacuum channel; 6 – central vacuum channel and resin overflow vessel; 7 – lightweight steel frame of the top part of the mold; 8 – resin inlet channel; 9 – lightweight steel frame of the bottom part of the mold; 10 – reinforcement package; 11 – rigid heated bottom part of the mold; 12 – heating system

In the RTM process, first, the glass mat is placed between the top (2) and bottom (11) parts of the mold to

act as reinforcement (10), like in manual lamination. Then, to produce vacuum, air is forced out of the closed mold. The liquid resin mixture is fed into the system under pressure (Fig. 2). The mixture is drawn into the mold cavity and wets the glass mat (10); the excess resin leaves the mold through the outlet channels (6). When calculating the mixture amount, one needs to take account of some allowance. Finally, the product is cured and demolded.

By applying polyester or epoxy resins characterized by a low viscosity and a low curing temperature, it is possible to infiltrate the reinforcement. During the process of element formation in a closed mold under pressure, the composite components are pressed. It is recommended to use three-dimensional fiber reinforcement materials with appropriate elasticity and thickness (slightly thicker than the desired element wall).

The process duration may be reduced by applying heated molds to accelerate the curing process. The maximum temperature is 80°C.

Resin infusion molding - experiment

The tests were carried out for a composite reinforced with fiberglass Syncoglas 5375/k500/375 on a polyester resin matrix, Palatal U570, applying a 2% hardener, Butanox M50.

The samples were produced at the Bella Composites Center, a manufacturer of composite materials. Before the composite formation using the infusion method, the reinforcement had to be prepared, the fiberglass mat parameters being as follows:

- dimensions 200 x 200 [mm]
- layer arrangement: 4 x T600
- glass content: 1600 [g/m²].

With the polymer-matrix composite components being ready, it was necessary to prepare the mold surface. A smooth glass plate was coated with wax and polished. Then, the reinforcement in the form of a glass mat was placed and covered with delamination fabric. The net responsible for resin distribution was placed in between the mat layers. Finally, the foil was put on top to prevent leakage. By folding the overlapping edges, it was possible to make the foil function as a vacuum bag.

Before the process of the composite formation, it is necessary to check the pump efficiency and the system leak tightness, as well as minimize any residual air left in the inlet and outlet pipes.

Fig. 3 shows the wetting of the dry reinforcement glass mat with a polyester resin occurring in the mold cavity. During the infusion, the mold is air-tight. One pipe connecting the vacuum pump with a system of ducts is responsible for maintaining vacuum. The other pipe submerged in a resin vessel supplies the liquid resin mixture to the dry reinforcement layers. After the glass mat is wetted, the vacuum pump and the resin vessels are disconnected. The composite is then gel coated at 21°C without applying additional load.

The samples made by applying the RIM and RTM methods were prepared and used for static tensile strength tests in accordance with the Polish standard PN-EN 10002-1+AC1, 1997. The tests were performed with an

INSTRON 8501 series IX at the Centre for Laser Technologies of Metals, the Kielce University of Technology, Poland.

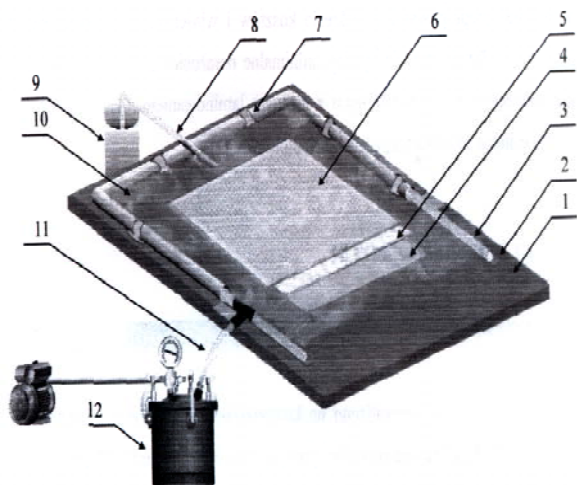

Fig. 3. Apparatus and process for the resin infusion molding: 1- glass mat, 2 – pressure-sensitive adhesive tape reinforcement, 3- spiral pipe, 4-reinforcement (glass mat), 5- resin distribution net, 6- delaminating fabric, 7- tape securing the inlet pipe, 8- inlet pipe, 9 - resin vessel, 10 - foil, 11- vacuum drawing pipe, 12- vacuum pump

Strength properties of a polymer-matrix composite formed with the RTM and RIM methods

Table 2 shows the process parameters of the two technologies of composite formation involving injection of liquid resin into a mold.

Table 2. Parameters of the polymer-matrix composite formation

Technology	Resin	Hardener	Injection to remolding time	Injection time	Gelling time
Infusion	Palatal U570	2% Butanox M50	approx. 2 h	3 min. and 30 sek.	2 h
RTM	Polimal 109-32K	Peroxan M50L 40 ml	2 h and 20 min	2 min	20 min

In the RTM process, the accelerating agent Peroxan M50L added to the resin Polimal 109-32K in the amount of 15g per kilo of resin improved the composite parameters by 20-25%. The same composite obtained with the infusion method increased its strength properties by approximately 60%, which was due to better packing of macro particles in between polymer composite components.

As can be seen from Fig. 4 (a and b), the mechanical properties of a composite produced with the RIM method depend on the fiber orientation in the glass mat layers.

The scatter of results concerning the physico-mechanical properties of a fiberglass-reinforced composite shows that the process quality and fiber reinforcement orientation are important. It was reported that the mechanical properties are dependent on the amount and the

type of a substance added to the polymer, the fiber quality and orientation, and also on the operating conditions.

Table 3. Properties of a polymer-matrix composite obtained by applying the RTM and infusion technologies

Composite	RTM	Infusion
σ [MPa]	$\frac{114,61}{112,42 \div 116,84}$	$\frac{199,73}{167,20 \div 229,90}$
E [MPa]	$\frac{2035,70}{1996,80 \div 2075,31}$	$\frac{5502,30}{4606,06 \div 6333,33}$

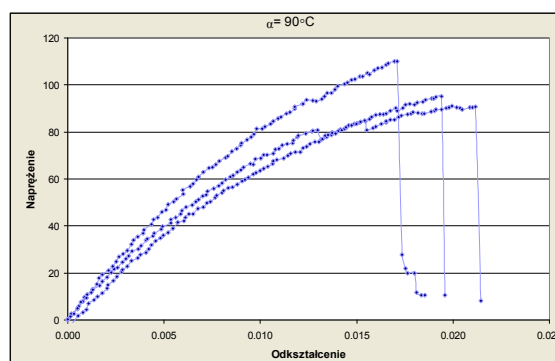

a

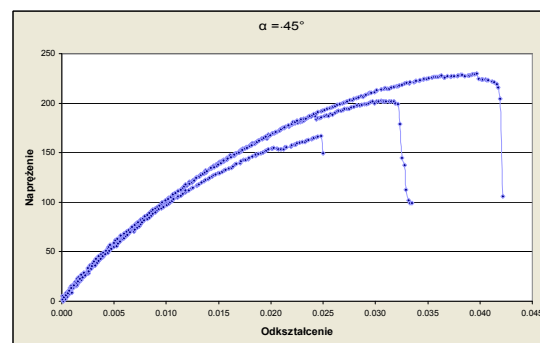

b

Fig. 4. Influence of the fiber orientation in the glass mat on the mechanical properties of the composite after infusion: a - $\alpha = 90^\circ$, b - $\alpha = 45^\circ$

As it is possible to control the microstructure, and, as a result, the final properties of composite materials, the modeling of distribution of static tensile stresses in a composite requires analyzing the effect of atmospheric factors [6].

Influence of temperature

Temperature plays a crucial role in the formation of polymer-matrix composites. If it is too high, certain structural materials cannot be produced.

Table 4 shows the effect of temperature forecast for a composite obtained with the RIM method.

An increase in temperature causes worse mechanical properties of a composite. The case is illustrated by smaller values of L_{kr} , through which stress is regrouped to adjacent

fibers. This leads to a decrease in the strength limit in a given micro volume owing to a smaller area of material surface, and in consequence, the composite destruction. In the model, the failure criteria were determined by analyzing the failure of the weakest fiber.

Table 4. Influence of temperature on the strength properties of a polymer-matrix composite produced with the resin infusion molding method

T [K]	ε	L_{kr} [mm]	τ_{lok} [MPa]	σ_{max} [MPa]
<i>infusion</i>				
293	3,63	0.977	3.065	192.821
393	3,49	0.948	2.485	155.648
<i>infusion after 2 years</i>				
293	3,63	0.992	3.155	198.858
393	3,49	0.930	2.390	149.219

Influence of time and temperature

It was reported that the strength properties of a composite are not only temperature- but also time-dependent. When studying the total composite failure due to aging, one needs to analyze the combined effect of temperature and time. The model takes into account changes in the material strength caused by temperature and time for the RIM and RTM methods (Table 5).

Depending on the temperature, aging may be accelerated or retarded. As a result, the physico-mechanical properties improve or worsen. The phenomena occurring in the material components cause that the maximum stress (σ_{max}) decreases more rapidly due to temperature and time than due to temperature only.

Table 5. Influence of temperature and time on the strength properties of a polymer-matrix composite

T [K]	ε	L_{kr} [mm]	τ_{lok} [MPa]	σ_{max} [MPa]
<i>RTM</i>				
293	3.63	0.603	1.787	98.782
393	3.49	0.704	1.365	79.806
<i>RTM after 2 years</i>				
293	3,63	0.597	1.751	93.018
393	3,49	0.697	1.338	81.649

Conclusions

The results of experiment can be summarized as follows.

- The mechanical properties of a polymer-matrix fiberglass-reinforced composite produced with the RIM method were 59% higher than those produced with the RTM method (better packed macro particles because of the reinforcement wetting).
- A study of the weakest layer shows changes in the physical and mechanical properties of the element in use and therefore changes in the stresses between the layers;
- In the assumed model, the curing of the polymer coating results in an increase in the strength parameters. When a composite is subjected to the influence of two climatic factors, i.e. temperature and time, simultaneously, incubation time excluded, the decrease in the strength parameters and, therefore, an increase in the matrix elasticity is greater than in the case of one climatic factor – temperature – acting on the composite.
- The modeled values of stresses between the composite layers coincide with those obtained in the experiment.

References

1. Guigon M. and K. Jinkin M. The interface and interphase in carbon fibre-reinforced composites. Journal "Composite". 1994. Vol. 25. P.534-539.
2. Karpiński J. Zastosowanie techniki resin infusion do budowy form. Journal "Technologie". 2004. Nr.10. P.25-27.
3. www.huntsman.com - Airtech.
4. Guigon M. and K. Jinkin M. Wpływ warunków wtryskiwania na właściwości dynamiczne kompozytu PP z włóknem szklanym. Journal "Composite". 2004. Nr.12. P.374-377.
5. Kleinhofs M. and Chatys R. Non-Destructive Testing of Composite Materials in Aircraft by Acoustic Emission Method. International Conference "Airplanes and Helicopters Diagnostics" AIRDIAG 2001. Ameliówka. 16-19 10.2001. P. 200-206.
6. Chatys R., Koruba Z. and Kleinhofs M. Nowe materiały dla bezpilotowych aparatów latających. (New Materials to Unmanned Aerial Vehicles). International Conference on Scientific Aspects of Unmanned Aerial Vehicle. 1997. Journal "Mechanika". 2004. Nr.80. P.77-83.

I. Chatys, R. Chatys

Technologijos ir atmosferos poveikis savybėms

Reziumė

Sustiprintų polimerinių matricių junginiais sudėtingų medžiagų technologijų savybės tirtos veikiant atmosferai. Analizuotos dvi technologijos: RIM (junginio sutvirtinimo dervų poveikis) ir RTM (junginio dervų sutvirtinimo poveikis). Jėgos modeliuotos skirtingiems eksploataavimo režimams ir skirtingoms audinio orientacijoms. Be to, ištirtos matricių polimerinio junginio kitos fizikinės ir mechaninės savybės.

Received 06 06 2006

DOI: 10.5755/j01.u.61.4.17000