

## Peculiarities of application of shear acoustic waves for non-destructive testing

S. Sajauskas, P. Serafinavičius

Department of Electronics Engineering, Kaunas University of Technology  
Studentų st. 50, LT-51368 Kaunas, Lithuania

### Abstract

The analysis of application of shear waves use in non-destructive tests, advantages in comparison with longitudinal waves during testing of pipes, welding joints and interval cracks are given. The results of experiments with shear waves when testing solid bodies with holes and the influence of Rayleigh waves on a cylindrical hole surface to the reflected signal shape are presented.

**Keywords:** non-destructive testing, shear waves, Rayleigh waves.

### Introduction

In some cases shear acoustic waves are used not only for measuring physical and mechanical parameters of solid bodies, but for non-destructive testing of products. Excitation of shear acoustic waves and their transmission to the object is complicated comparing with the longitudinal waves. This happens due to physical nature of the shear waves and their interaction with a solid body surface or specific effects of streaks.

One of such effects is excitation of longitudinal surface acoustic waves (LSAW) by a shear wave, when the angle of incidence to the free surface of solid body is less  $90^\circ$  [1]. Whereas LSAW propagating in the plane surface of cracks emit lateral shear waves; so, the reception of shear waves can give information about the defect and enables to estimate a shape of the defect.

The edge waves, that are obtained when reflection of shear waves comes from a streamline defect, are also described in a literature. The surface waves reaching a sharp corner of a defect are transformed to shear and longitudinal bulk waves [2]. The edge wave term does not describe their physical nature, but only show their correlation with a shape of the defect. Actually, these are Rayleigh waves [2] or LSAW [3,4].

Ultrasound non-destructive testing with shear waves is broadly applied for non-destructive testing of welding joints and pipes [2]. In those cases the shear waves are excited by angular transducers, transforming longitudinal wave into the shear wave immediately at the boundary between the prism of the angular transducer and the specimen.

The main advantages of shear waves for finding the defects in comparison to longitudinal waves are:

1. The velocity of shear waves is about twice less than that of longitudinal waves ( $c_L/c_T \cong 2$ ) and  $\lambda_L/\lambda_T \cong 2$ ; therefore the smaller defects can be detected by shear waves.

2. Reflection of shear waves from cracks with rough surface because the crack surface friction is stronger.

The specific properties of shear waves, their excitation means and practical applications discovering the effectiveness of using shear waves for non-destructive testing are described in this paper.

### The principles of shear waves excitation

The angular method is classical, mostly used for excitation of shear waves. In this case, bulk longitudinal waves fall to the solid body surface by a sharp angle and transform to bulk shear waves propagating in a solid body (Fig. 1). The major advantage of the angular method is that shear waves in the object can be excited by an angular transducer without solid acoustic contact, i.e. through a thin layer of the liquid. This possibility is very attractive for non-destructive testing.

Generally, when the incident wave is plane and there is no diffraction, two bulk waves (longitudinal and shear) at the boundary between two solid bodies reflected from the boundary and two bulk waves (longitudinal and shear) refracted in the second solid body are generated (Fig. 1). Their propagating angles are described by the Snell's law:

$$\frac{\sin \vartheta}{c'_L} = \frac{\sin \beta_T}{c'_T} = \frac{\sin \gamma_L}{c''_L} = \frac{\sin \gamma_T}{c''_T}, \quad (1)$$

where  $\vartheta$  is the longitudinal surface wave incidence angle,  $\beta_L$  and  $\beta_T$  are the angles of reflected longitudinal and excited shear surface waves in the first solid body;  $\gamma_L$  and  $\gamma_T$  are the angles of refracted longitudinal and excited shear surface waves;  $c'_L$  and  $c'_T$  are the velocities of longitudinal and shear surface waves in the first solid body;  $c''_L$  and  $c''_T$  are the velocities of longitudinal and shear surface waves in the second solid body.

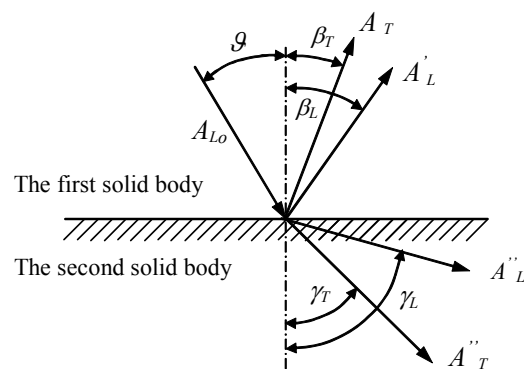

Fig.1. Conversions of bulk longitudinal surface waves at the boundary of two solid bodies

The propagation direction of the waves depends not only on longitudinal wave's incidence angle, but also on acoustical properties of both media when wedge transducers of shear waves are used. These properties are described by acoustical waves velocities. From Eq.1 follows that the shear wave propagation angle is

$$\gamma_T = \frac{c_T''}{c_L''} \arcsin \vartheta. \quad (2)$$

Shear waves can be excited only at the incidence angles  $\vartheta < \vartheta_{kr}''$  when  $c_L' < c_T'' < c_L''$ , and they propagate in the specimen only in particular angular sector. The diffracted bulk longitudinal waves propagate in the second solid body when the condition is  $\vartheta < \vartheta_{kr}^I < \vartheta_{kr}''$ , so, it means, in a noticeably more narrow angular sector.

The dependences of the bulk shear waves  $c_L''$  and the longitudinal waves  $c_T''$  propagation angles  $\gamma_L''$  and  $\gamma_T''$  on the longitudinal waves incidence angle  $\vartheta$  in the wedge of plexiglas ( $c_L' = 2730$  m/s) for steel ( $c_L'' = 5900$  m/s;  $c_T'' = 3200$  m/s) and duralumin ( $c = 6320$  m/s;  $c_T'' = 3130$  m/s) are presented in Table 1 and 2.

Table 1. The dependence of propagation angle of shear waves the incidence angle of bulk longitudinal waves

**Steel**

$\vartheta$ , degrees	$\gamma_L''$ , degrees	$\gamma_T''$ , degrees
10	21,7	11,8
15	34,0	17,6
20	22,3	23,6
25	66,1	29,7
$\vartheta_{cr}^I = 27,6$	90,0	32,8
30		35,8
35		42,2
40		48,8
45		55,8
50		60,5
$\vartheta_{cr}'' = 58,6$		90,0

**Duralumin**

$\vartheta$ , degrees	$\gamma_L''$ , degrees	$\gamma_T''$ , degrees
10	23,8	11,5
15	36,9	17,3
20	52,4	23,1
25	78,2	29,0
$\vartheta_{cr}^I = 25,6$	90,0	29,7
30		35,0
35		41,1
40		47,5
45		54,2
50		61,4
$\vartheta_{cr}'' = 60,7$		90,0

Shear waves propagate in steel, when  $\vartheta \leq 58,6^{\circ}$ , and in aluminum, when  $\vartheta \leq 60,7^{\circ}$ . This limits the possibilities of

ultrasound non-destructive testing with shear waves. On the other hand, bulk shear waves excited by the angular method are not replicable when testing welded joints, as it is possible to send them under the joint.

Only shear bulk waves exist in the second solid body, when the incidence angle range is  $\vartheta_{kr}^I \leq \vartheta \leq \vartheta_{kr}''$  (Table 1). In steel it is in enough wide angular sector  $32,8^{\circ} \leq \gamma_T'' \leq 90^{\circ}$ , in duralumin –  $29,7^{\circ} < \gamma_T'' < 90^{\circ}$ . It is important to say that there is no lateral wave, therefore, bulk longitudinal waves do not exist in these angular sectors in the specimen.

This circumstance allows avoid ambiguity when estimating the reflected signals from the defects and improves the reliability of non-destructive testing. Therefore, non-destructive tests using shear waves are widely applied in very responsible cases, e.g., for testing of welded joints or the quality of pipe walls.

**Shear wave transducers**

Measurement of physical and mechanical parameters of solid bodies is related to measuring phase velocities of longitudinal and shear waves. If measurement of phase velocity of longitudinal waves makes no difficulties, whereas it is necessary to have transducers radiating these waves perpendicularly to the plane of propagation for measuring phase velocity of shear waves.

One of possible ways to design such transducer of shear waves is given in [5]. This method is based on reflection coefficients of longitudinal and shear waves from free surface  $R_{LL}$  and  $R_{TL}$ . It is shown that dependencies of these coefficients on the incidence angle  $\vartheta$  are described by the following equations:

$$R_{LL} = \frac{\sin 2\vartheta \sin 2\beta_T - (c_L/c_T)^2 \cos^2 2\beta_T}{\sin 2\vartheta \sin 2\beta_T + (c_L/c_T)^2 \cos^2 2\beta_T}, \quad (3)$$

$$R_{TL} = \frac{2(c_L/c_T)^2 \sin 2\vartheta \cos 2\beta_T}{\sin 2\vartheta \sin 2\beta_T + (c_L/c_T)^2 \cos^2 2\beta_T}. \quad (4)$$

The dependencies of the reflection coefficients  $R_{LL}$  and  $R_{TL}$  on the incidence angle  $\vartheta$  are shown in Fig. 2. There can be seen that at the particular angle  $\vartheta_0$ , the reflection coefficient  $R_{LL} = 0$  and all the energy of the incident wave is transformed to the shear wave propagating at the angle  $\beta_T$  without any loses. The angle  $\vartheta_0 = 61^{\circ}$  is for the steel wedge [4],  $\vartheta_0 = 42^{\circ}$  – for the melted quartz [5]. Such design of the transducer is useful, because there is no need to use Y-cut quartz. It is necessary to make a solid acoustical contact for excitation of shear waves in the specimen using this transducer. This is the major inconvenience; therefore the wedge transducers are used mostly for non-destructive tests. Usually a conventional ultrasound non-destructive testing is complemented with different kinds of angular transducers. The angular transducer with an adjustable incidence angle is preferable for more accurate tests.

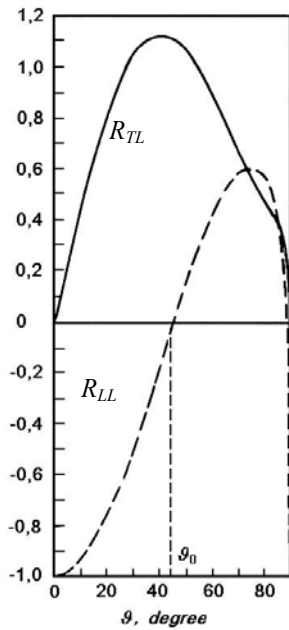

Fig. 2. The dependency of reflection coefficients  $R_{LL}$  and  $R_{TL}$  on the incidence angle  $\vartheta$  [5] of melted quartz

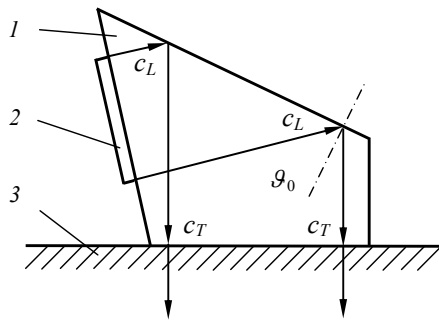

Fig. 3. The transducer of shear waves without lateral modes: 1 - wedge; 2 - piezocrystal; 3 - solid body

The *Krautkrämer* transducers with adjustable angles are most widely used (Fig. 4). This angular transducer consists of a plexiglas wedge, i.e. case 1 with the hole where the cylindrical figure piezo-crystal header 2 from the same material is placed. The plane is milled in the header till the axial line with the glued piezo-crystal 3 made from PZT piezoceramics. The entire empty cavity and a narrow gap between the body (the wedge 1 and the cylindrical header 2) are filled with a couplant (silicone oil). The bulk plane ultrasonic wave crosses the cylindrical insert into the wedge 1 almost without losses, because the acoustic contact is made between the two concentric cylindrical surfaces of the same material and the thickness of the couplant layer is  $\ll \lambda$ . During excitation of shear waves by the angular method a part of the bulk acoustic wave 6 reflects to the solid prism and is attenuated when it propagates in it or is scattered because of multiple reflection on the structures 5 formed on the wedge 1 surface.

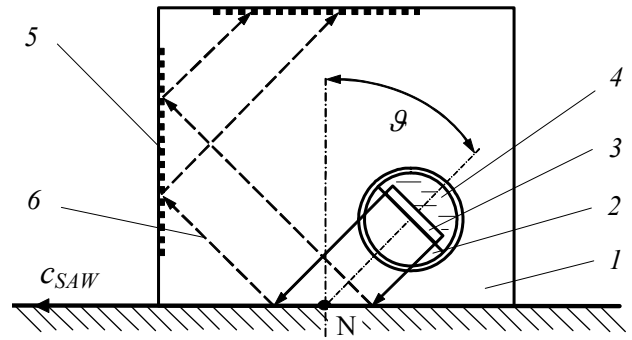

Fig. 4. Simplified angular transducer's construction of a variable angle: 1 - plexiglas wedge; 2 - cylindrical plexiglas rotating header of piezo-crystal; 3 - piezo-crystal; 4 - cylindrical cell with the couplant liquid; 5 - bulk acoustic waves scattering surface structure; 6 - lateral bulk waves

The described angular transducer has several advantages, such as: a good acoustic contact stable when changing the incidence angle  $\vartheta$ ; minimal acoustic losses because of the change of incidence angle  $\vartheta$ . The dependence of the acoustic energy access at the solid surface point N on the incidence angle  $\vartheta$  is the only shortcoming; so, the acoustic properties remain constant when the optimum incidence angle is fixed, e.g.  $\vartheta = \text{const}$ .

### Results of experimental investigation using shear waves

The investigations were carried out using ultrasound digital non-destructive testing set-up [3]. The flaw detector UD2-12 (Moldova) standard angular transducers and adjustable angle 2-4 MHz transducers made by us were used for excitation of shear waves. Special specimens from steel and duralumin with rectangular shape cuts and various cylindrical holes (for pipes) were made.

Shear waves pulse signals reflected from perpendicular corner and the vertical notch in a rectangular profile specimen were registered (Fig. 5). Those artificial defects imitated cracks in welding joints (Fig. 6). Big amplitudes of reflected signals even from not deep notches show that the shear waves are very useful for detecting such defects.

As it can be seen, the amplitude of the reflected signal from 2mm depth notch (Fig. 2, c) is only by 30% less than from the specimen with the perpendicular corner. Bulk longitudinal waves [2] with angles  $15^\circ < \beta < 75^\circ$  almost are not reflected.

The advantage of shear waves against longitudinal is especially clear during non-destructive testing of pipes. Fig. 6 shows the signals that were registered when shear waves reflected from cylindrical holes of various diameters in a steel pipe. Shear waves were excited using the angular transducer П121-2,5-50°, with a concave radiating surface (the curvature radius is equal to the outer pipe radius  $R$ ).

The ratio of the reflected signals and noise is  $\geq 18$  dB. When the diameter of the hole has changed from 10 to 1 mm, the signal decreases only twice. Fig. 7 shows 5 MHz longitudinal bulk waves reflection signal, received by the same direct transducer probing the hole from the end of the pipe, when the transducer distance from the hole and the excitation voltage were the same as in the previous test. It

is obvious that the amplitude of the signal is less than in the case of with shear waves.

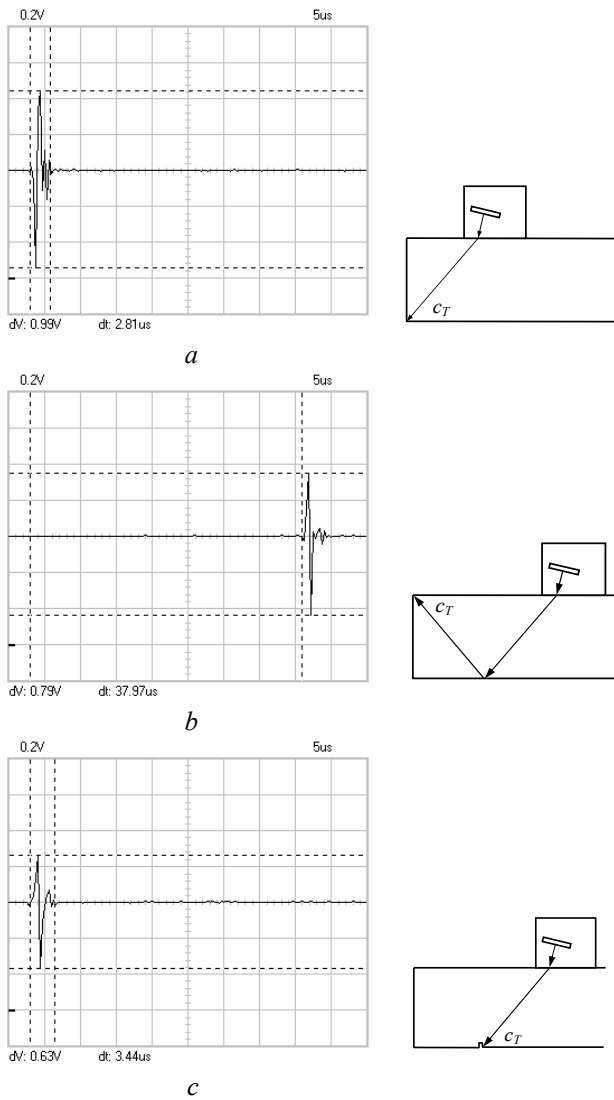

Fig.5. Reflection of shear waves pulse reflection from inner perpendicular corner (a, b) and from 2 mm depth transverse notch (c). Duralumin specimen thickness is 40 mm, signals were registered using the standard angular transducer П121-2,5-50<sup>0</sup>

Also it was mentioned that signal shape of shear wave (Fig. 6) is enough complex and its shape depends on the diameter of the hole. This phenomenon can be explained as the signal consists of several interfering different types of waves (reflected shear and surface wave propagating around the hole).

The investigations of the complex signal shape obtained in a rectangular duralumin solid body (200×100×20 mm) with the cylindrical hole of 10 mm diameter were performed.

The reflected signal of shear waves was received by the standard angular transducer П121-2,5-50<sup>0</sup>. The signal consists of several separate non-overlapping pulses (Fig. 8). The big diameter of the hole and enough short probing pulse are the reasons of this effect. The surface wave signal propagates around the hole, so it becomes delayed in comparison to the reflected shear waves pulse. There was

also observed the signal propagating the second time around the hole. The additional delay time was 9,9 μs. According to this delay the surface waves phase velocity  $c_{SAW} = 3172$  m/s was calculated and it was almost equal to the Rayleigh waves velocity in duralumin ( $c_R = 3130$  m/s).

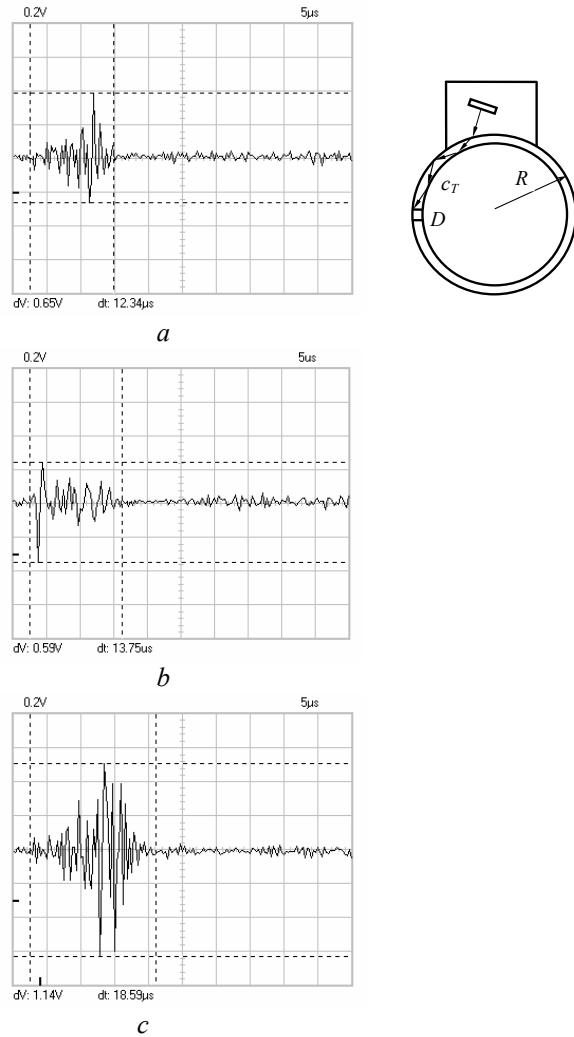

Fig.6. Signals of shear waves reflected from the hole of 48 mm diameter in a steel pipe of 3 mm thickness, when the diameter of the hole D is: a - 1 mm; b - 3 mm; c - 10 mm

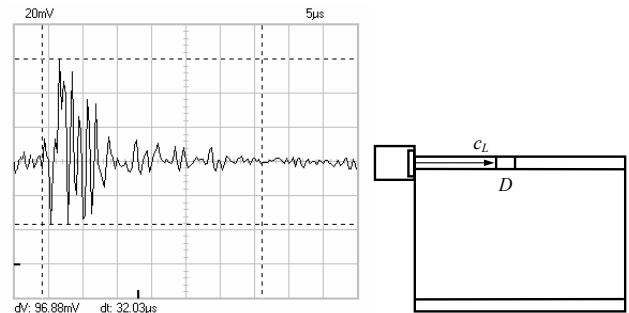

Fig. 7. Signal of longitudinal waves reflected from D=10 mm hole in 48 mm of outer diameter steel pipe, thickness of wall is 3 mm. Signal received using the standard 5 MHz transducer П111-5-K6, when the distance from the hole is 40 mm

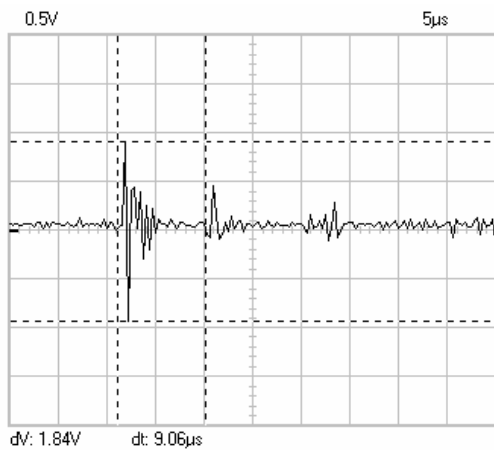

Fig. 8. Reflection of shear waves from the cylindrical hole in rectangular duralumin specimen.

## Conclusions

The results of experimental investigation allow to make the conclusion about the effectiveness and advantages of application of shear waves for non-destructive testing of pipes, vertical surface cracks, welding joints in comparison with longitudinal waves.

One of the greatest advantages in ultrasonic testing using this type of waves is that their excitation by the angular method in a wide angular sector allows tests by shear waves without lateral longitudinal waves. This

increases the reliability of ultrasonic signal identification and correspondingly, of non-destructive testing.

## Literatūra

1. **Sajauskas S., Valinevičius A., Miežutavičiūtė L.** Non-destructive testing of sheet product inner surfaces using longitudinal surface acoustic waves. *Ultrasound*. 2005. No.1(54). P. 12–16.
2. **Krautkrämer J., Krautkrämer H.** *Werkstoffprüfung mit Ultraschall*. –Berlin – Heidelberg – New York – London – Paris - Tokyo: Springer Verlag. 1986. P. 752.
3. **Sajauskas S.** Longitudinal surface acoustic waves (Creeping waves). Kaunas: Technologija. 2004. P. 176.
4. **Sajauskas S., Minialga V.** Paviršinių išilginių ir paviršinių skersinių bangų sąveikos su išoriniu kampu eksperimentiniai tyrimai. *Ultragarsas*. 2002. Nr.1(42). P. 42–45.
5. **Kino S.** *Acoustic waves: Devices, imaging and analog signal processing*. – New Jersey, Prentice-Hall. 1990. P. 662. (Transl. in Russian).

S.Sajauskas, P. Serafinavičius

## Skersinių bangų naudojimas neardomiesiems bandymams

### Reziumė

Pateikiama skersinių bangų naudojimo neardomiesiems bandymams analizė, aptarti šių bangų sužadavimo metodai, pranašumai bandant vamzdžius, suvirinimo siūles ir vidinius įtrūkimus, palyginti su išilginėmis tūrinėmis bangomis. Pateikti eksperimentinių tyrimų skersinėmis bangomis bandiniuose su kiaurymėmis rezultatai, parodyta Reilėjaus bangų cilindriniam kiaurymės paviršiuje įtaka atsispindėjusių signalų formai.

Pateikta spaudai 2006 11 20

DOI: 10.5755/j01.u.61.4.17004