

The optimization of directivity patterns of acoustic antennas with piezoceramic rectangular bimorph transducers and flexural vibrations

A. Petrauskas

Kaunas University of Technology, Prof. K.Baršauskas Ultrasound Institute

E-mail: Algimantas.petrauskas@ktu.lt

Abstract

To avoid the negative influence of peripheral transmission-reception during measurements, the improvement of directional characteristics of acoustic antennas using piezoceramic rectangular bimorph transducers with flexural vibrations is described. The most suitable designs of piezoceramic rectangular bimorph transducers in flexural vibration, used for various measurements, are being reviewed. The model of electromechanical vibrations for such transducers is described. Recommendations to use such transducers in acoustic antennas are also given. The optimal construction principles for acoustic antennas, which are being used in echolocation devices, are proposed. The obtained experimental results are also presented.

Keywords: piezoceramic rectangular bimorph transducers, flexural vibration, acoustic antenna, piezoelectric transducer for measurement, directivity patterns of acoustic antenna, parallel nodal lines of vibrations.

Introduction

For measurements in air (gas) environment, piezoceramic transducers in flexural vibration are widely used [1-9]. The usage of transducers with flexural vibrations gives the best possibility to match acoustic impedances of air and the transducer, because flexural transducers are characterized by sufficiently low acoustic impedance. Then the optimal transmission of measurement signals to the air and back is realized.

Flexural vibrations are best generated when using unimorph, bimorph or multimorph piezoelectric transducers [10-12], also by using various composite transducers with transformation of vibrations [13-19].

When measuring in air, unidirectional transmission-reception of signals is preferred. Additionally the peripheral transmission-reception should be as minimal as possible, because it is disruptive and produces measurement errors. Because of that, acoustic antennas using piezotransducers with flexural vibration are designed with the peripheral transmission-reception being minimal.

As will be shown below, the unidirectional transmission of piezotransducers can be made using rectangular bimorph piezotransducers with parallel nodal lines of vibrations [20-22]. Also various composite transducers with transformation of vibrations can be used. Their working surfaces must be thin-walled and rectangular.

Study

Rectangular piezoelectric transducers were described in papers [5,7,8,20-22]. In other papers [13,22-25] the new look on forming of directivity patterns of transducers with flexural vibration is given. In papers [20-22] it is proposed, that for measurements in air environment it is best to use piezoceramic rectangular bimorph transducers with parallel nodal lines of vibrations. In one plane, a directivity patterns of such transducers is the same as of piston-piezotransducers. In a perpendicular plane, if a flexural transducer is flat, it reveals a four-leaf (four directional) directivity patterns and the inclination angle α between a normal to a flat surface and direction of

radiation. This angle depends on ratio of velocities of the acoustic waves in the transducer and in air [16-23]:

$$\sin \alpha_{1,2} = \pm \frac{k_{\delta} \lambda_a}{2l}, \quad (1)$$

where α is the an angle between the normal to a flat surface and the direction of radiation; λ_a – the length of the acoustic wave in air; k_{δ} – the number of nodal lines in a transducer; l – the length of a transducer in the direction of flexural vibrations.

As shown below, the unidirectional transmission of piezotransducers can be achieved using rectangular piezotransducers with four-leaf directivity patterns.

The vibration modes of flat and rod-like piezoelements were analyzed theoretically in [18, 20-22].

We will look at the most widely used piezotransducer's (Fig. 1) vibration modes.

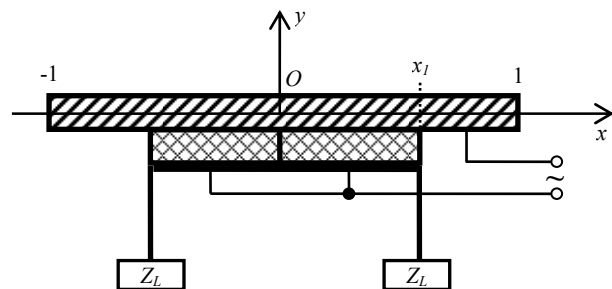

Fig.1. Cross section of a rectangular transducer attached to elastic plate. Z_L is load (metallic plate's) impedance against transversal shifts

The piezotransducer (Fig. 1) is made using two rectangular piezoceramic plates with different polarization. The plates are mounted on a rectangular elastic plate. The elastic plate radiates the vibration of the transducer to the air environment. When piezoplates are identical, at their juncture a nodal line of flexural vibration is always present and the vibrations of the transducer are symmetric to the juncture line. Therefore it is sufficient to analyze the vibrations of the transducer in the segment Ox_1 .

The impedance Z_{δ} of a rectangular bimorph piezotransducer is related to the impedance of the plate Z_L [18]:

$$Z_{\delta} = \frac{jZ_L}{\beta}, \quad (2)$$

where β – the parameter describing the phase and shape of vibrations, subject to the load of the bimorph [18]; $j = \sqrt{-1}$.

$$|Z_{\delta}| = v_{\delta} \cdot \rho_{\delta} \cdot S_{\delta}, \quad (3)$$

where v_{δ} – the length of the bimorph flexural wave; ρ_{δ} – the density of the bimorph; S_{δ} – the surface area of a cut, perpendicular to x axis.

The vibrations $\xi_{\delta}(x)$ of the bimorph in the segment Ox_l are described using this expression [18]:

$$\xi_{\delta}(x) = \xi_{\delta}(x_1) \cdot \Phi(\alpha_{\delta}), \quad (4)$$

where α_{δ} – the argument of bending coupling factor and the coordinate x_j ; $\Phi(\alpha_{\delta})$ – complex expression of Prager and Krylov function [26-28].

The resonant frequencies of a piezoelectric bimorph are obtained using this equation [18]:

$$1 + \cos \alpha_{\delta} \operatorname{ch} \alpha_{\delta} + \beta (\sin \alpha_{\delta} \operatorname{ch} \alpha_{\delta} - \cos \alpha_{\delta} \operatorname{sh} \alpha_{\delta}) = 0, \quad (5)$$

where

$$\alpha_{\delta} = \frac{v_{\delta} \cdot x_1}{2\pi f}, \quad (6)$$

where f – the frequency of vibrations.

Eq. 5 root dependency on the parameter β is shown in Fig. 2.

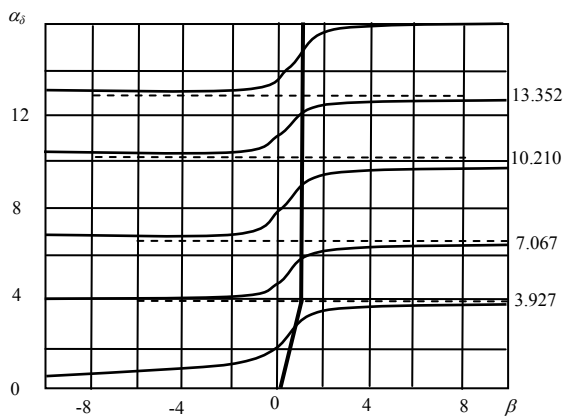

Fig. 2. Dependency of parameter α_{δ} on β

The discontinuity of the function α_{δ} can be found using this equation:

$$\sin \alpha_{\delta} \operatorname{ch} \alpha_{\delta} - \cos \alpha_{\delta} \operatorname{sh} \alpha_{\delta} = 0. \quad (7)$$

In practice, usually the second resonant frequency of a bimorph piezotransducer is used [18]. The dependency of such transducer's vibration mode on inertial and elastic load is shown in Fig. 3a and 3b.

From Fig. 3 we can see that $\xi(x)$ value and shape greatly depend on the parameter β . When elastic load increases, the conversion of bimorph's vibration phase occurs. To achieve optimal functionality of a bimorph, it needs to be joined with a resonant plate (segment x_l , Fig. 1). In this case the shape of bimorph's vibrations does not change. The length of the plate must be such that it would be equal to half of a flexural wavelength. Impedance of the plate must be as small as possible. Then the shape of the transducer's vibration will be similar whether the transducer is loaded or not. The length of a flexural wave,

which corresponds to the parameter β , can be approximately obtained from Fig. 2.

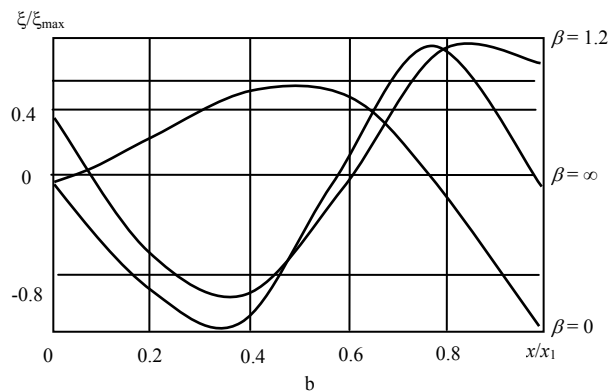
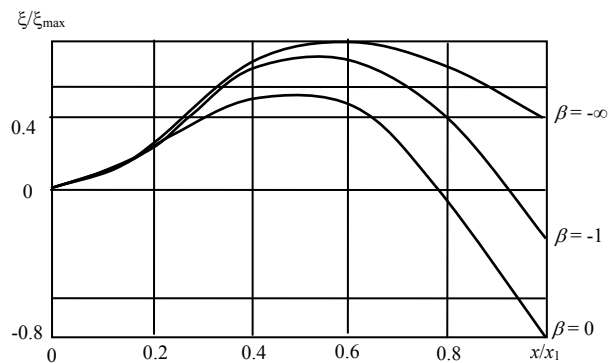

Fig.3. The dependency of such transducer's vibration mode on inertial (a) and elastic (b) load

This technique can also be used to design complex transducers [14,25].

The quality of acoustic measurement instruments strongly depend on directivity pattern of acoustic antennas. In most situations the directional properties of antennas must be unidirectional.

The cross section of a unidirectional acoustic antenna [29] is shown in Fig. 4.

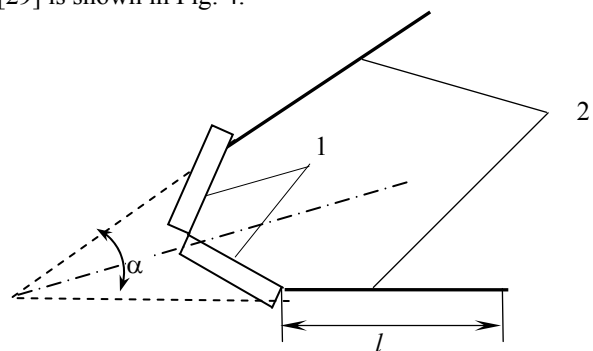

Fig.4. Cross section of unidirectional acoustic antenna: 1 – rectangular bimorph piezotransducers; 2 – reflectors of acoustic waves

The acoustic antenna (Fig. 4) is made using two rectangular bimorph piezotransducers (1), which are aligned with the angle α , and two reflectors of acoustic waves (2):

$$\alpha = 2 \arcsin(\lambda_a / \lambda_{\delta}). \quad (8)$$

where λ_a – the length of the acoustic wave in air; λ_δ – the length of the flexural wave in a bimorph.

The length l of the plates (2) is approximately equal $(7-10) \lambda_a$. When α is approximately equal 30° (Fig. 4), the level of peripheral transmission is reduced by half (Fig. 5).

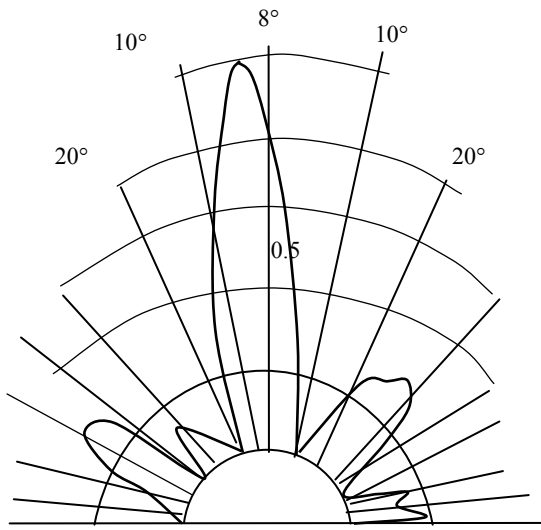

Fig.5. Directivity pattern of acoustic antenna (Fig. 4)

In Fig. 6 the cross section of an unidirectional acoustic antenna is shown [30]. The acoustic transmission in this antenna is increased by using two additional reflectors placed behind two rectangular bimorphs.

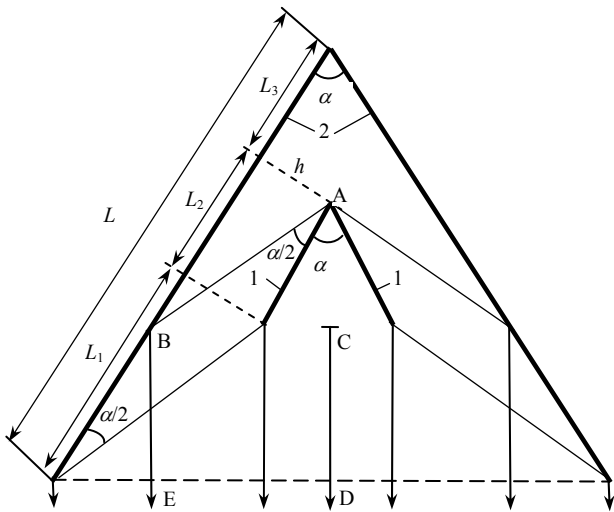

Fig.6. Cross section of unidirectional acoustic antenna: 1 – rectangular bimorph piezotransducers; 2 – reflectors of acoustic waves

In the aperture of the antenna the radiation of both bimorphs (1) is added. The distance h from the reflector to the bimorph is calculated:

$$h = \frac{m\lambda_a}{2\sin(\alpha/2)}, \quad (9)$$

where $m = 1, 2, 3, \dots$

The length of a reflector L (Fig. 6) must meet this condition:

$$L \geq \frac{m\lambda_a \cos(\alpha/2)}{\sin^2(\alpha/2)} + l_2. \quad (10)$$

In such design of the antenna 3 (out of 4) directional leaves of the radiation are being used for measurement [32] t. When bimorph is vibrating in the second vibration mode [18,33], the directivity pattern [34-36] of the antenna (Fig. 6) is shown in Fig. 7.

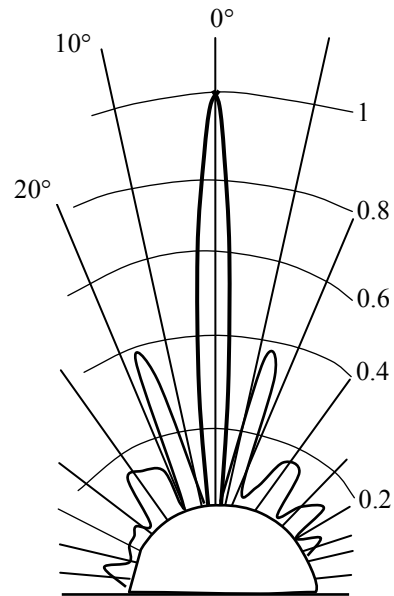

Fig.7. Directivity pattern of acoustic antenna (Fig. 6)

In Fig. 8 is a cross section of a similarly working antenna is shown. In this case the acoustic antenna is composed of an array of three bimorphs (aa_1, bb_1, cc_1) [7].

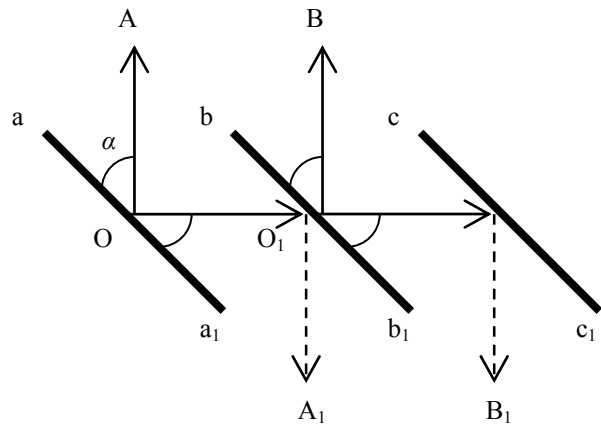

Fig.8. Cross section of bidirectional acoustic antenna

In this case the directivity pattern is two-leafed. The radiation propagates in two directions (A, B and A_1, B_1). The unidirectional diagram of this antenna can be obtained when a reflector is placed on one side of the array of bimorphs.

As we can see from Fig. 5 and Fig. 7, the acoustic antennas, composed of rectangular bimorphs has a peripheral radiation up to 25%. Because of this radiation, difficulties to use such antennas in echolocation instruments arise.

As shown in papers [31], the near field of a bimorph in flexural vibration is shorter than a field, produced by a piston-piezotransducer. This property can be used to

eliminate peripheral radiation by using sound-absorbing plates (Fig. 9).

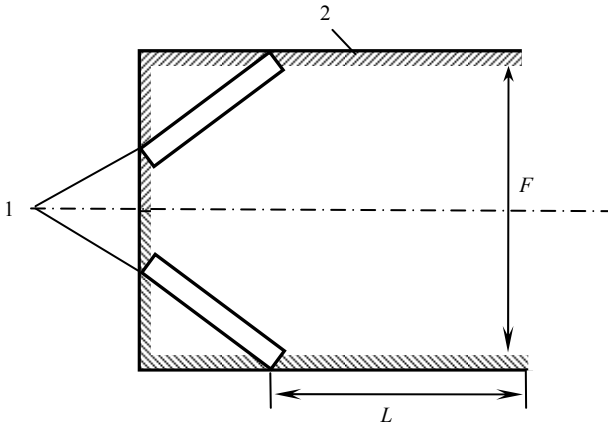

Fig.9. Cross section of unidirectional acoustic antenna: 1 – rectangular bimorph piezotransducers; 2 – absorber of acoustic waves.

The length l of the absorber must meet the following condition:

$$L = (F/2) \cdot \cot \alpha, \quad (11)$$

where α – the angle between maximum and the first minimum of the directivity pattern; F – the aperture of the acoustic antenna.

In Fig. 10 the directivity pattern of such acoustic antenna (Fig. 9) is shown.

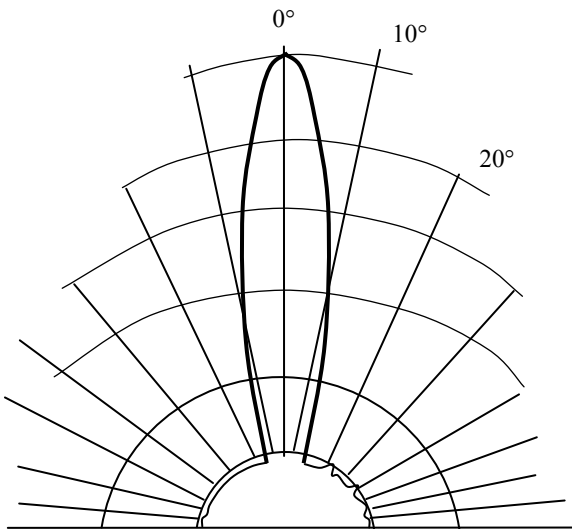

Fig.10. Directivity pattern of acoustic antenna (Fig. 9)

It needs to be mentioned that when designing acoustic antennas, other rectangular transducers in flexural vibration [16,17] can be used in place of bimorphs.

For example, various composite transducers with transformation of vibrations can be used (Fig. 11).

The transducer is composed of a piezoceramic transducer (1), concentrator of acoustic waves (2) and a thin-walled rectangular elastic plate (3). In this case, vibrations with parallel nodal lines are excited in a thin-walled rectangular elastic plate [17]. In this case the elastic plate operates in the same way as rectangular bimorphs mentioned above.

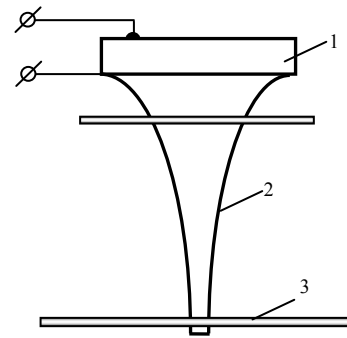

Fig.11. Cross section of composite transducer with transformation of vibrations: 1 – rectangular or circular piezotransducer; 2 – concentrator of acoustic waves; 3 – thin-walled rectangular elastic plate

If the plate (3) is bent with angle α in its place of attachment, the unidirectional acoustic antenna is obtained [7] (Fig. 12).

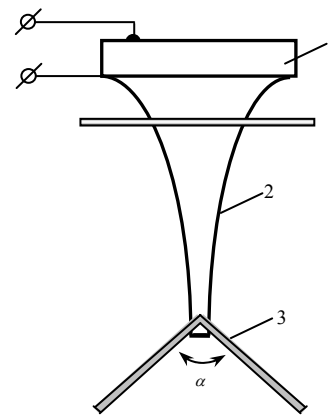

Fig.12. Cross section of composite transducer with transformation of vibrations: 1 – rectangular or circular piezotransducer; 2 – concentrator of acoustic waves; 3 – thin-walled rectangular elastic plate bent with angle α

In this case, two (out of four) directional leaves of the radiation are being used to obtain a unidirectional antenna. The radiation of the antenna will be at maximum, when $\alpha=90^\circ$, and the length of the flexural wave in a plate $\lambda_\delta \approx 1.4\lambda_a$.

Conclusions

The unimorphic and bimorphic rectangular transducers with parallel nodal lines of vibrations can successfully be used to design unidirectional acoustic antennas. The unidirectional directivity pattern of such antenna can be obtained when combining various designs of bimorph arrays. The peripheral radiation can be eliminated by additionally using sound-absorbing plates in the nearest acoustic field.

References

1. **Massa F.** Ultrasonic transducers for use in air. Proc. IEEE. 1965. Vol 53, (10). P.1363-1371.
2. **Yamane H., Kawamura M.** Sound sources with vibration plates in flexural modes and reflection plates for airborne ultrasonics. J. Acoust. Soc. Japan. 1976. Vol. 32, (2). P.83-91.

3. **Bindal V. and Chandra M.** An improved pjezoelektric ceramic transducer for ultrasonic applications in air. Archives of Acoustics. 1982. Vol.7 (3-4). P. 281-286.
4. **Honda Y., Matsuhisa H. and Sato S.** Radiation efficiency of a baffled circular plate in flexural vibration. Journal of Sound and Vibration. 1983. Vol.88 (4). P. 437-446.
5. **Петраускас А., Домаркас В.** Особенности работы прямоугольных биморфных электроакустических преобразователей со свободными краями (in Russian). Вильнюс: Минтис, Ультразвук (Ultrasound). 1974. Nr.6. P.103-108.
6. **Barone A, Gallego-Juarez J A.** Flexural vibrating free-edge plates with stepped thickness for generating high directional ultrasonic radiation. JASA, 1972, Vol.51(3) P.953-959.
7. **Petrauskas A.** Investigation and construction of measuring transducers for ultrasonic devices using flexural vibrations. Ph. D. thesis. Kaunas. 1975. P.147. (in Russian).
8. **Petrauskas A., Razutis P.** Improvement of the efficiency of a bimorph rectangular piezoelectric transducer. ISSN 1392-2114 Ultragarsas (Ultrasound). Kaunas: Technologija. 1999. Nr.1(31). P.23-24.
9. **Petrauskas A., Razutis P.** Investigation of echolocational ultrasonic methods by increasing accuracy in level measurements. ISSN 1392-2114 Ultragarsas (Ultrasound). Kaunas: Technologija. 2001. Nr.4(41). P.18-21.
10. **Germano C.P.** Flexure Mode Piezoelectric Transducers. IEEE Transactions on audio and electroacoustics. 1971. Vol.AU-19, (1). P.6-12.
11. **Babic M.** A 200-kHz ultrasonic transducer coupled to the air with a radiating membrane. Ultrasonics, Ferroelectrics and Frequency Control, IEEE Transactions, 1991, Vol.38, P.252 – 255.
12. **Brissaud M.** Theoretical modelling of non-symmetric circular piezoelectric bimorphs. Journal of Micromechanics and Microengineering. 2006. Nr. 16. P.875-885.
13. **Мажонас А., Петраускас А., Домаркас В.** Авт. Свид. СССР Nr.1077062, кл. B06B 1/06, 1984, Бюл. Nr.8 (in Russian).
14. **Домаркас В., Петраускас А. Мажонас А.** Многоэлементные пьезокерамические преобразователи изгибных колебаний. ISSN 636-6367 (in Russian), Вильнюс: Минтис, Ультразвук (Ultrasound). 1981. Nr.13. P.24 - 29.
15. **Петраускас А., Мажонас А., Шидлаускас С.** Излучение составного пьезоэлектрического преобразователя с различными сферическими сегментами. ISSN 0369-6367 (in Russian), Вильнюс: Минтис, Ультразвук (Ultrasound). 1985. Nr.17. P. 39-44.
16. **Matsuzava K.** Sound sources for producing intense ultrasonic fields in small regions in air. – In: Eighth International Congress on Acoustics. London, 1974. Vol.11. P.709.
17. **Домаркас В., Петраускас А.** Пьезоэлектрический преобразователь с трансформацией вида колебаний (in Russian). Вильнюс: Минтис, Ультразвук (Ultrasound). 1975. Nr.7. P.127-132.
18. **Петраускас А., Приалгаускас С., Мажонас А.** Исследование колебаний составных круглых пьезопреобразователей. ISSN 0369-6367 (in Russian), Вильнюс: Минтис, Ультразвук (Ultrasound). 1987. Nr.19. P.107-113.
19. **Домаркас В., Мажонас А., Петраускас А.,** Изгибные колебания составных прямоугольных пьезопреобразователей. ISSN 0369-6367 (in Russian), Вильнюс: Минтис, Ультразвук (Ultrasound). 1989. Nr.21. P.43-50.
20. **Домаркас В., Петраускас А.** Колебания асимметричных биморфных пьезоизлучателей (in Russian). Вильнюс: Минтис, Ультразвук (Ultrasound). 1976. Nr.8. P.57-64.
21. **Домаркас В., Петраускас А.** Биморфные пьезокерамические преобразователи для измерений в газовых средах (in Russian), Вильнюс: Минтис, Ультразвук (Ultrasound). 1978. Nr.10. P.55-64.
22. **Домаркас В.** Эквивалентные четырехполосники асимметричных биморфных пьезоэлектрических преобразователей. ISSN 0369-6367 (in Russian), Вильнюс: Минтис, Ультразвук (Ultrasound). 1984. Nr.16. P.20-30.
23. **Домаркас В., Петраускас А.** Авт. Свид. СССР Nr.379291 (in Russian).
24. **Домаркас В., Петраускас А.** Авт. Свид. СССР Nr.496051, кл. B06B 1/06, 1975, Бюл. Nr.47 (in Russian).
25. **Домаркас В., Петраускас А.** Авт. Свид. СССР Nr.547975, кл. B06B 1/06, 1977, Бюл. Nr. 7 (in Russian).
26. **Теумин Н. И.** Ультразвуковые колебательные системы (in Russian). Moscow: Машгиз, 1959. 332 с.
27. **Бабиков И. П.** Теория колебаний (in Russian). Moscow: Госиздат технико-теоретич. литературы. 1958. P. 627.
28. **Kikuchi E.** Ultrasonic Transducers (in Russian). Moscow: Mir, (1972). P.424.
29. **Домаркас В., Мажонас А., Петраускас А.** Исследование характеристик направленности пьезопреобразователей изгибных колебаний. ISSN 636-6367 (in Russian), Вильнюс: Минтис, Ультразвук (Ultrasound). 1983. Nr.15. P.48-51.
30. **Мажонас А., Петраускас А., Приалгаускас С.** Усовершенствование ультразвуковых антенн для газовых сред. ISSN 0369-6367 (in Russian), Вильнюс: Минтис, Ультразвук (Ultrasound). 1987. Nr.19. P.121-125.
31. **Мажонас А., Петраускас А.** Оптимизация характеристик направленности акустических антенн. ISSN 0369-6367 (in Russian), Вильнюс: Минтис, Ультразвук (Ultrasound). 1984. Nr.16. P. 84-87.
32. **Домаркас В., Мажонас А., Петраускас А.** Акустическое поле прямоугольных преобразователей изгибных колебаний с жестко закрепленными краями. ISSN 0369-6367 (in Russian), Вильнюс: Минтис, Ультразвук (Ultrasound). 1986. Nr.18. P. 3-10.
33. **Minialga V., Sajauskas S., Petrauskas A.** Modeling of directivity patterns of transducer for ultrasonic measurement. ISSN 1392 – 2114 Ultragarsas (Ultrasound). Kaunas: Technologija. 1997. Nr 2(28). P. 23-24.
34. **Minialga V., Petrauskas A.** Estimation of directivity patterns of two rectangular acoustic radiators oriented at various angles. ISSN 1392 – 2114 Ultragarsas (Ultrasound). Kaunas: Technologija. 1998. Nr 1(29). P. 20-23.
35. **Minialga V., Petrauskas A.** Evaluation of vibrations of acoustic spherical antenna by laser interferometer. ISSN 1392 – 2114 Ultragarsas (Ultrasound). Kaunas: Technologija. 2004. Nr 3(52). P.
36. **Minialga V., Petrauskas A.** Testing and optimization of ultrasonic pulse locating antenna by laser vibrometer. Sixs International Conference on Vibrations Measurements by Laser Techniques: Advances and Applications, edited by Enrico Primo Tomasini. Proceedings of SPIE. 2004. Vol. 5503. P. 225-232.

A. Petrauskas

Akustinių antenų iš lanksčiai virpančių stačiakampių pjezokeraminių keitiklių kryptingumo charakteristikų optimizavimas

Reziumė

Nagrinėjama, kaip pagerinti akustinių antenų, sudarytų iš lanksčiai virpančių pjezokeraminių keitiklių, kryptingumo charakteristikas, kad būtų išvengta matavimams trukdančio periferinio spinduliavimo priėmimo. Todėl apžvelgtos tinkamiausios matavimams pjezokeraminių keitiklių konstrukcijos. Aprašytas tokių keitiklių elektromechaninių virpesių modelis. Pateikta siūlymų dėl lanksčiai virpančių keitiklių naudojimo akustinėse antenose. Pasiūlyti optimalių akustinių antenų konstravimo, siekiant jas panaudoti akustinės lokacijos prietaisuose, principai. Pateikti eksperimentiniai matavimų rezultatai.

Pateikta spaudai 2007 03 25

DOI: 10.5755/j01.u.62.1.17015