

## Stability of length measurement comparator's carriage under artificial excitation

A. Kilikevičius \*, D. Sabaitis\*\*

\* Department of Machines Engineering Vilnius Gediminas Technical University

J. Basanavičiaus Str. 28 LT-2009 Vilnius, Lithuania. Mob. phone: +370 677 55819 E-mail: [akilikevicius@gmail.com](mailto:akilikevicius@gmail.com)

\*\* Department of Engineering Designing Joint Stock Company VILMA

Žirmūnų Str.68 LT-09124 Vilnius, Lithuania. Mob. phone +370 600 44450 E-mail: [deividas\\_sabaitis@yahoo.com](mailto:deividas_sabaitis@yahoo.com)

### Abstract:

Response to external excitation of length measurement comparator's carriage is analyzed in the article. For this purpose measurement and external excitation systems were composed. The measurement system consisted of an accelerometer and acceleration signal processing equipment. To cause the excitation, the outer excitation element (vibrator) with the possibility to control the frequency of vibrations was used. Amplitude of displacements was analyzed, which was achieved by integrating the acceleration measured by a vibrometer vibratory twice. The results obtained at different frequencies were compared and conclusion presented.

**Key words:** comparator, artificial excitation, stability .

### Introduction

Survey of literature [1, 2, 3, 4, 5] data shows that operation principles of precision length measurement comparator carriage drives and designs influence essentially on a measurement accuracy. It is due to dynamic impact on reading quality because at use of scotch length measures, influence of vibration is a significant factor influencing the reading accuracy. The being designed precision length measurement comparator [5 - 8] is the most accurate length measurement mean in Lithuania. During analysis of dynamic errors it is necessary to know vibration velocity amplitude values of a carriage in order to evaluate influence of carriage drives and dampers on a vibration activity of the carriage and on the measurement accuracy.

Vibration activity of a carriage and its influence to measurement accuracy is analyzed in this paper. By measuring the vibratory acceleration of the carriage with

accelerometer, which is integrated by the vibrometer twice, the signal of particle displacement is received

### Experimental equipment and methodology of the research

The comparator is with a movable microscope and immovable scale. The stand is made of granite and is placed on the foundation. For decreasing the level of external vibrations vibro-isolating supports are used. The part of the equipment transporting devices being used for readings consists of two carriages (Fig. 1). One is force carriage, the another is precision. Drive providing equipment (a motor, worm reduction gear, friction drive etc.) is mounted on a force carriage, while the microscope with a view chamber, flash and retro reflector of a laser interferometer are put on the precision carriage. The carriages are connected with one another by the rod and move on aerostatic ways with respect to to granite stand.

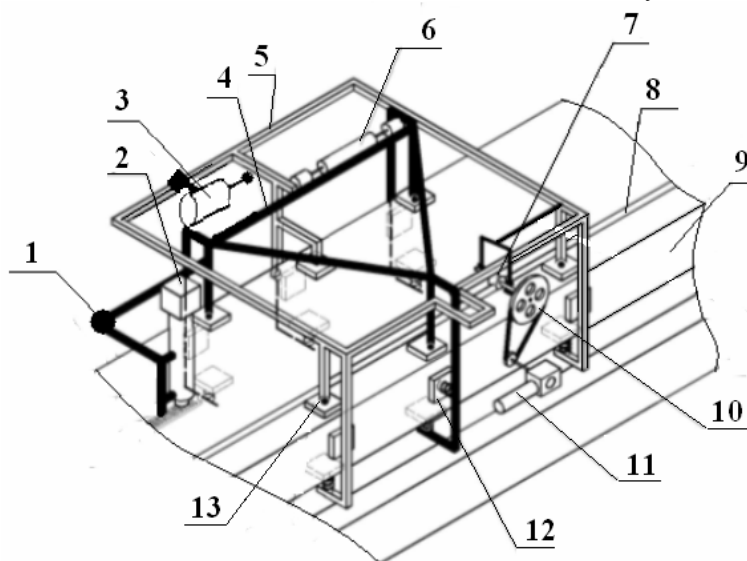

Fig.1. Structural diagram of the comparator's carriage: 1 – measurement point; 2 – microscope with camera and flash; 3 – outer excitation element; 4 – frame of the precision carriage; 5 – frame of force carriage; 6 – joint member of two carriage; 7, 8 – friction gear; 9 – granite guideway; 10 – belt drive; 11 – electromotor with reducer; 12 – springy aerostatic bearing; 13 – tight built aerostatic bearing.

The outer excitation element (vibrator) was tight by fixed to the force carriage. During the research, on a moving carriage, excitation frequency of the vibrator was changed and vibratory acceleration on the precision carriage was measured with the accelerometer. The carriage vibration acceleration measurements were performed using the accelerometer 8306, the vibrometer 2511 and the signal input – output board Ebiol-Comlab-SeiTech and the precision computer IBM-50. Methodic of signal processing is described in literature [5 - 8].

Computer processing of a measurement signals was performed by the aid of the program package Origin 6. Spectra, distributions and statistic parameters of signals were calculated:

- arithmetic mean  $\bar{x}$ , mm/s:

$$\bar{x} = \frac{1}{n} \sum_{i=1}^n x_i ;$$

- root mean square deviation:

$$S_X = \sqrt{\frac{1}{n-1} \sum_{i=1}^n (x_i - \bar{x})^2} ;$$

- scattering:

$$x_{scatter} = |x_{max}| + |x_{min}| .$$

There  $n$  is the number of measurement results,  $x$  – is the measurement result.

### Measurement results

While measuring the amplitude of displacements it was noticed that, by exciting at different frequencies, displacement amplitude is similar and is in the range from -5 to +5  $\mu\text{m}$ .

Amplitude of displacement is presented in Fig.2 (without excitation) and typical amplitude of displacement in Fig.3 (at various frequencies); more detailed information and statistical parameters are given in Table 1.

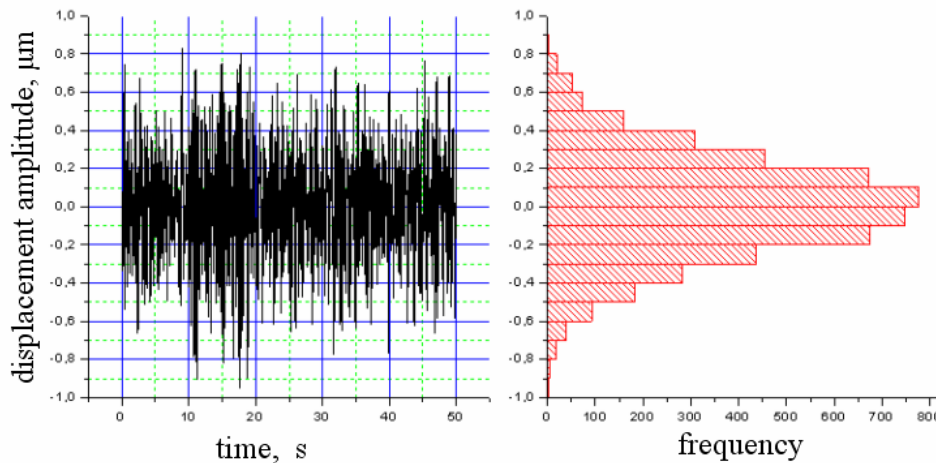

Fig.2. Signal of the vibration displacement and its histogram (without excitation)

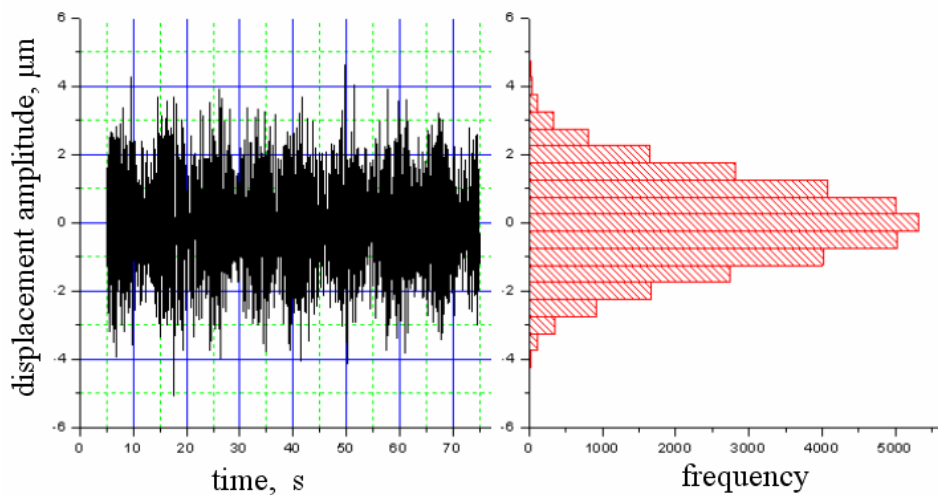

Fig.3. Typical signal of the vibration displacement and its histogram (with excitation)

Table 1. Statistical parameters of the vibration displacement measurement signal

Frequency of excitation, Hz	Statistical parameter				
	Arithmetical mean, [ $\mu\text{m}$ ]	Root mean square deviation	Minimum value, [ $\mu\text{m}$ ]	Maximum value, [ $\mu\text{m}$ ]	Scatter, [ $\mu\text{m}$ ]
Without excitation	-2,162E-6	0,262	-0,947	0,827	1,774
3	-1,858E-5	1,273	-5,052	4,635	9,687
5	3,908E-5	1,262	-4,622	4,943	9,565
7	-2,616E-5	1,277	-4,359	4,986	9,345
9	-4,954E-6	1,388	-4,747	4,824	9,571
11	2,834E-5	1,376	-5,728	5,380	11,108
13	7,877E-6	1,339	-4,642	4,679	9,321
15	2,514E-5	1,349	-5,117	5,034	10,150

The obtained results are presented in Fig. 4–7.

As seen from the pictures, amplitudes of the vibration displacements (being various frequency of excitation) are

from 0,42  $\mu\text{m}$  (at the frequency of excitation 15 Hz) to 0,75  $\mu\text{m}$  (the frequency of excitation 3 Hz) and without excitation respectively from 0.0042  $\mu\text{m}$  to 0,062  $\mu\text{m}$ .

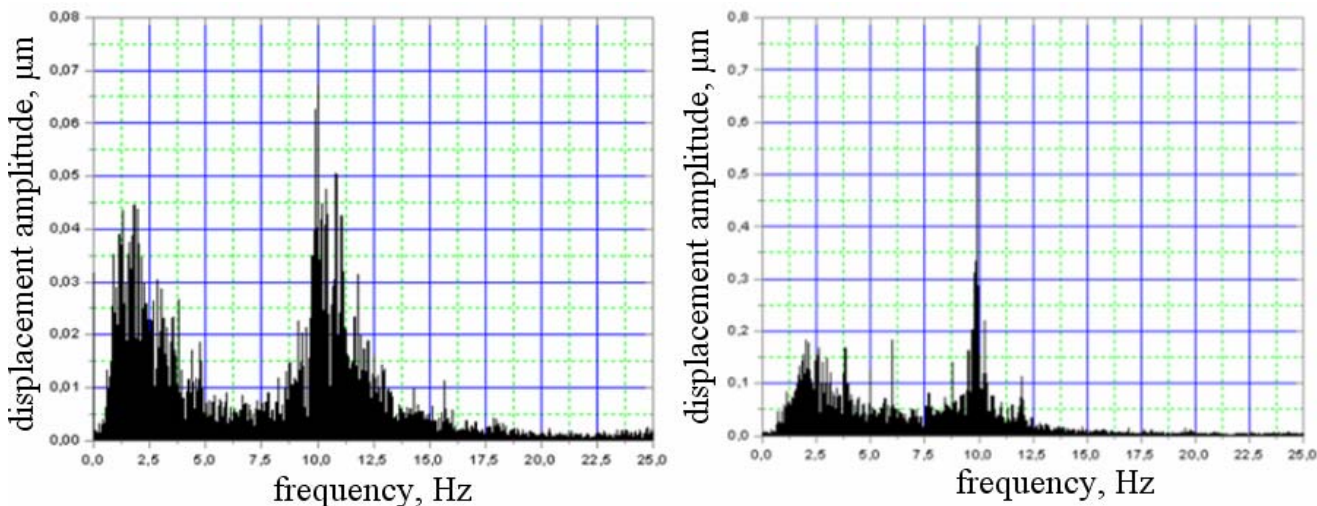

Fig. 4. Spectra of the vibration displacement (without excitation (left) and the frequency of excitation is 3 Hz (right))

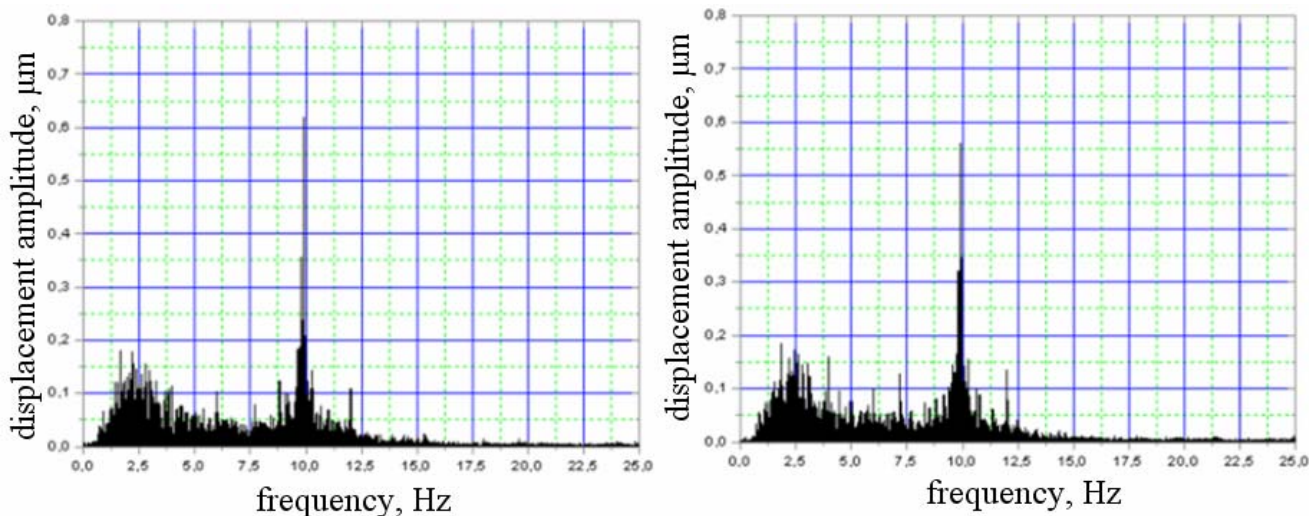

Fig. 5. Spectra of the vibration displacement (when the frequency of excitation is 5 Hz (left) and 7 Hz (right))

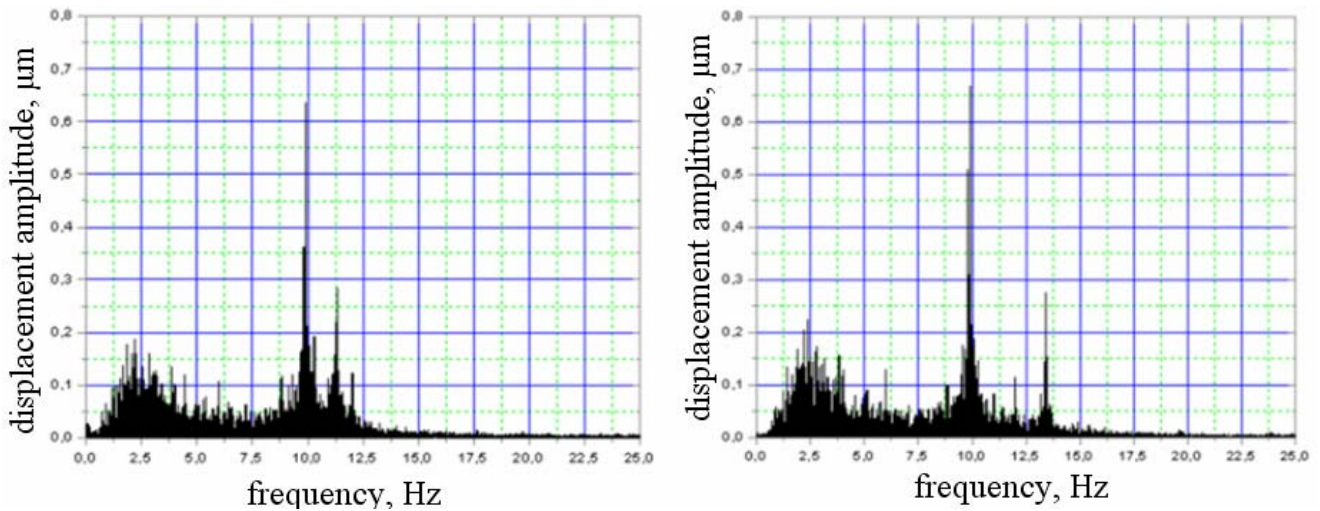

Fig. 6. Spectra of the vibration displacement (when the frequency of excitation is 9 Hz (left) and 11 Hz (right))

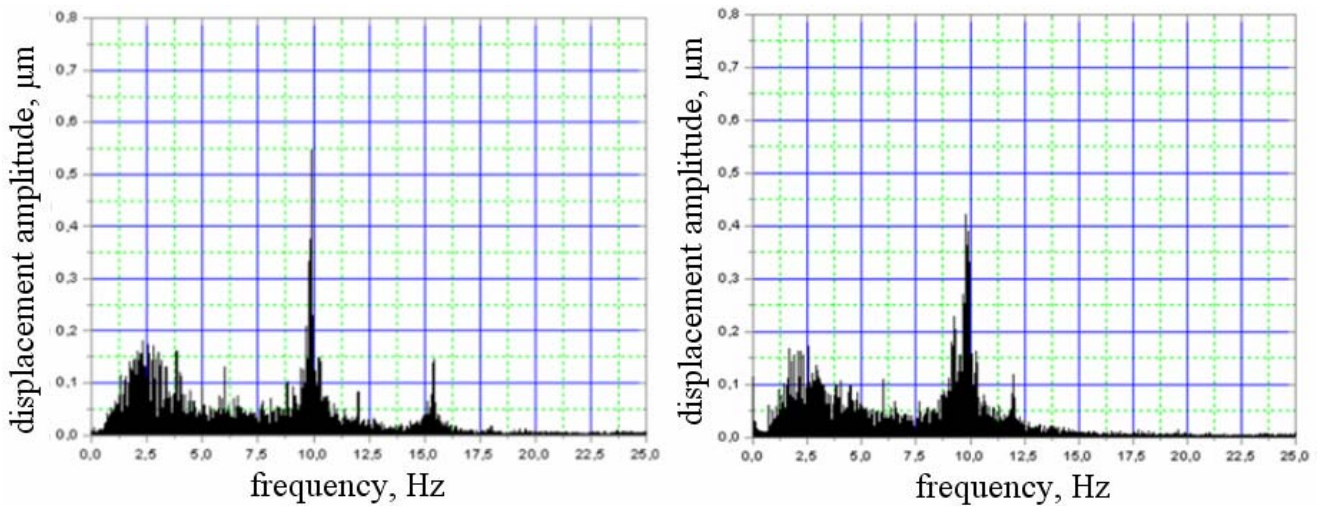

Fig. 7. Spectra of the vibration displacement (when the frequency of excitation is 13 Hz (left) and 15 Hz(right)).

### Discussion of the results

As seen from the measurement results, the dominant amplitude of the vibration displacement is at 10 Hz and the amplitude fluctuates from 0,42 to 0,75  $\mu\text{m}$  (with excitation) and from 0,042 to 0,062  $\mu\text{m}$  (without excitation). Maximum amplitudes of the vibration displacement are at 3 Hz, 9 Hz and 11 Hz. When the frequency is increasing, the amplitude is decreasing. At the frequencies 9 Hz and 11 Hz other vibration displacement amplitudes are seen – from 0,27 to 0,29  $\mu\text{m}$ . Statistical parameters show, that maximum root mean square deviation and scatter are at the frequencies 9 Hz and 11 Hz.

### Conclusions

1. The investigation shows, that the frequency of vibrations of the system is about 10 Hz.
2. In the test-measurement time, the frequency information read may not be coincide with the resonant frequency of the system.

### References

1. Sawabe M., Maeda F., Yamaryo Y., Simomura T., Saruki Y., Kubo T., Sakai H. and Aoyagi S. A new vacuum interferometric comparator for calibrating the fine linear encoders and scales Precision Engineering. July 2004. Issue 3. Vol.28. P. 320-328.
2. Thalmann R. A new high precision length measuring machine, progress in precision engineering and nanotechnology. Proceedings of the 9-IPES/UME4, Braunschweig, Germany. 1997. Vol.1. P. 112-115.
3. Demarest F. C. High-resolution, high-speed, low data age uncertainty, heterodyne displacement measuring interferometer electronics. Meas. Sci. Technol. 1998. Vol. 9. P. 1024-1030.
4. Beers J. S. and Penzes W. B. The NIST length scale interferometer. J. Res. Natl. Inst. Stand. Technol. 1999. Vol.104. P. 225.
5. Nano: 1D gratings, WGDM-7: Preliminary comparison on nanometrology according to the rules of CCL key comparisons. Final report, Draft B, Wabern. 30. November 2000. P. 34.
6. Kasparaitis A., Vekteris V., Kilikevichus A. A vibration source in comparator. Seventh International conference on vibration measurements by laser techniques: Advances and applications. Ancona, Italy. ISBN 0277-786X/06. Vol.63452006.

7. **Kilikevičius A., Vekteris V.** Vibrations sources acting the comparator stand. Proceedings of the 11th International conference. Mechanika. Kaunas. 2006.
8. **Kilikevičius A., Vekteris V.** Diagnostic testing of the comparator carriage vibrations. Kaunas: Technologija. ISSN 1392-2114 Ultragarsas. 2006. Nr. 2(59). P. 26-30.
9. **Vekteris V., Kilikevičius A.** Research of vibrations acting the mechatronical comparator. Zbornik 4. simpozijuma sa meždunarodnim učeščem „KOD 2006“ Zbornik Radova Proceedings. Palič. 2006.

A. Kilikevičius, D. Sabaitis

**Ilgio matavimo komparatoriaus kariatėlės stabilumas esant dirbtiniam žadinimui**

Reziumė

Nagrinėjamas ilgio matavimo komparatoriaus kariatėlės atsakas į išorinį žadinimą. Tyrimo tikslui pasiekti buvo sudarytos matavimo ir išorinio žadinimo sistemos. Matavimo sistemą sudarė akcelerometras ir pagreičio signalą apdorojanti įranga. Žadinimui sukelti buvo naudojamas išorinio žadinimo elementas (vibratorius), kurio virpėjimo dažnį galima reguliuoti. Buvo nagrinėjama poslinkio amplitudė, gauta du kartus integruojant vibracinį pagreitį vibrometru. Duomenys, gauti žadinant kariatėlę skirtingais dažniais, palyginti ir pateiktos išvados.

Pateikta spaudai 2007 12 06

DOI: 10.5755/j01.u.63.1.17060