

Courseware for ultrasonic medical diagnostics curriculum: system for on-site and remote laboratory experiments

R. Jurkonis¹, V. Marozas^{1,2}, A. Lukoševičius¹

¹ *Institute of Biomedical Engineering, Kaunas University of Technology*

² *Signal processing department, Kaunas University of Technology*

Abstract

The aim of this paper is to present the implementation approach of on-site and remote experimenting laboratory for ultrasound medical diagnostics curriculum. We demonstrate the implementation of such laboratory using virtual instrument that is built by using a standard computer, a ultrasonic transducer with a tissue like phantom, digitizer, function generator and the software package LabView. By controlling the virtual instrument it is possible to excite and receive ultrasound waves in the pulse echo mode, then process the received echographic signal and get the characteristics of the tissue like phantom. The tissue like phantom is characterized with thickness and density also with the speed of wave's propagation and attenuation coefficient. The students are motivated by the assignment of the precise task - to identify the material from which the phantom is made. The implemented on-site experiments system is based on a virtual instrument, the remote experiments system and is tested using the LabView remote panel technology as well. This technology allows accessing the experiment system remotely using an internet browser. We expect the students will improve their knowledge of ultrasound medical diagnostics using our hands-on lab experiment system.

Keywords: ultrasound, medical diagnostics, on-site laboratory, remote laboratory

Introduction

John Dewey (1859-1952) was an American philosopher and educator whose writings and teachings have had profound influences on education in the United States and around the world [1]. Dewey's philosophy of education called pragmatism and teaching methods focused on learning-by-doing (experiential learning) rather than rote learning and dogmatic instruction, which were common practices in his days. New communication and calculation technologies make feasible the Dewey's ideas as a new kind of laboratories- remote laboratories appear with real interactive experiments by using internet connected laboratory equipment: measurement instruments and devices under investigation. Emerging technologies of electronic learning and teaching platforms are spreading in the higher education system. Many examples of remote labs for different subjects do exist already: in electronics [2] and microelectronics [3], systems and control [4] and photonics [5].

However, the implementation of a remote lab for specific subject as Ultrasound medical diagnostics is not widely published yet in review survey papers [6, 7, 8]. We can refer to grant awarded implementation by H. Ewald et.al [9], who published their experience in remote ultrasound experiments. The specifics of ultrasound technology and the importance of knowledge in ultrasound diagnostics motivated us to create the advanced courseware for graduates in Biomedical Engineering program. In this paper we present laboratory experiment implementation approach in one example of characterization of tissue like materials analogous to learning concept described above.

Didactic adaptation of characterization method

Images of internal anatomy provide the information

from traditional sonographic systems, which provide the qualitative type of data. Research publications show the increasing specialization of sonographic systems for diagnostics of particular organs and increasing demand for quantitative data about tissues. Description of biological tissue non-invasively in quantitative parameters is called tissue characterization. We can provide a whole row of modern attempts of ultrasonic tissue characterization in scientific research papers: diagnostics of body common tumors [10]; diagnostics of breast tumors [11]; characterization of myocardium [12]; evaluation of vascular condition [13]; evaluation of eye [14], determination of liver suitability for transplantation [15], characterization of bones [16] and cartilage [17], tissue attenuation imaging [18]; or parametric imaging with sonographic system [19].

We have chosen the in-vitro experimental setup of the ultrasonic tract in our implementation approach. We used non-biological materials for characterization during student's laboratory experiments. The structure of the experimental setup is presented in Fig. 1.

A very important issue is to assure the equal distance d_l in both registration cases of the reference echogram and of the echogram from the phantom in experimental ultrasonic tract. By assuring the uniform distance d_l we were able to characterize parameters of the phantom tissue like material. The method of characterization is adopted from a few reference papers [20, 21, 22]. The time diagrams explaining experiments are shown in Fig. 2. There is presented the reference echogram from the reference interface water – steel, that has one echo pulse and parameters (τ_1, s_{Rm}) of echogram used for method development. The echogram from the phantom sample contains two echo pulses that are reflected from starting the interface at water - sample and ending the interface sample – air. The delays and amplitudes of echo pulses ($\tau_2, \tau_3, s_{1m}, s_{2m}$) are pointed out as well.

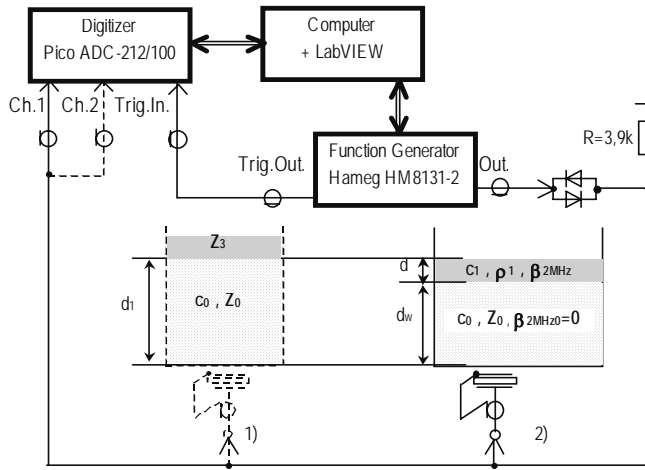

Fig. 1 The structure of experimental system setup

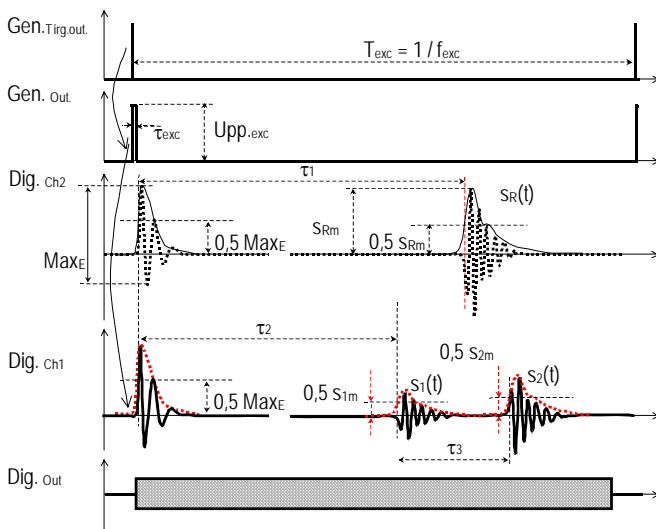

Fig. 2 The time diagrams of signals registered at several check points in experimental system

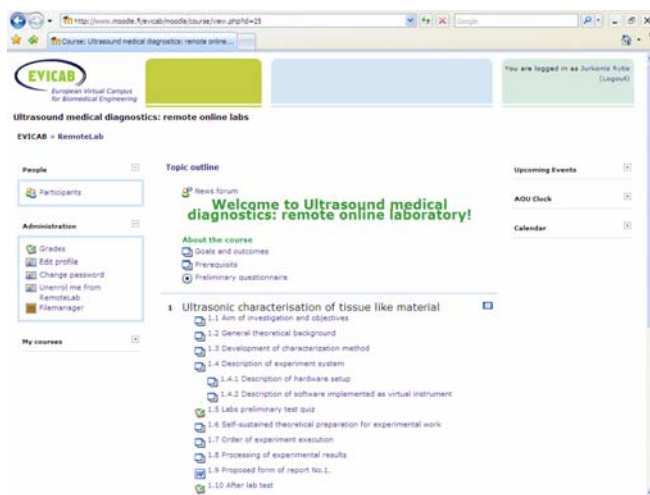

Fig. 3 The screenshot of Ultrasound Medical Diagnostics e-course implemented in Moodle virtual learning environment. It is possible to visit using this link: <http://www.moodle.fi/evicab/moodle> after registration

The comprehensive details of the method for ultrasonic characterization for tissue like materials are presented for the students in the e-learning materials available in Moodle virtual learning environment (Fig. 3). Below is the short description of the method itself.

The tissue characterization method

The first parameter characterizing the phantom is thickness d . In order to solve the problem of defining the distance d from the reference and the phantom echograms the system of equations must be solved. The delay of the reflected pulse from the interface water - steel and the delay of the reflected pulse from the interface water - phantom yields the system of two equations:

$$\begin{cases} \tau_1 = \frac{2 \cdot d_1}{c_0} \\ \tau_2 = \frac{2 \cdot (d_1 - d)}{c_0} \end{cases} \quad (1)$$

The solution of Eq.1 in terms of d leads to this result:

$$d = c_0 \frac{\tau_1 - \tau_2}{2} \quad (2)$$

In order to estimate the second parameter - sound propagation speed c , we use the same Eq.1. The solution appears to be:

$$c = c_0 \frac{\tau_1 - \tau_2}{\tau_3 - \tau_2} \quad (3)$$

The density ρ_1 of the phantom material is derived using the following equations:

$$\begin{cases} \rho_1 = \frac{Z_1}{c_1} \\ R_{01} = R_{03} \cdot \frac{s_{1m}}{s_{Rm}} \end{cases} \quad (4)$$

where, c_1 – is the speed of sound in the phantom material just estimated using Eq.3: Z_1 is the acoustic impedance of the phantom material, R_{03} is the reference reflection coefficient which we assume to be constant at the temperature of 20°C and its value students calculate in a self-contained theoretical part of experiment; s_{1m} is the amplitude of the reflected pulse from the interface water - phantom material, s_{0m} is the amplitude of impinging pulse at the interface water - phantom material. Let us assign the scalar value of ratio of amplitudes of the pulse $s_1(t)$ from the phantom and the pulse $s_R(t)$ from the reference materials as A_{1R} , which is calculated from pulses peak-to-peak values during processing of echographic pulses. Reflection from the interface water-phantom material is calculated using this basic equation:

$$R_{01} = \frac{(Z_1 - Z_0)}{(Z_1 + Z_0)} \quad (5)$$

where Z_0 is the impedance of the water.

By considering (4) and (5) the final equation for density ρ_1 gets this form [20]:

$$\rho_1 = \frac{Z_0}{c} \frac{1 + R_{03} \cdot A_{1R}}{1 - R_{03} \cdot A_{1R}} \quad (6)$$

The development of attenuation coefficient estimation method is similar to [20, 23, 24, 25], where the attenuation coefficient is estimated from registered attenuation frequency function. The starting point of attenuation definition is the basic expression of ratios of amplitude values of acoustic pressure signal at the input and output interfaces of the sample material:

$$\alpha(f) = 20 \cdot \log_{10} \left(\frac{S_{in}(f)}{S_{out}(f)} \right), \quad (7)$$

where $\alpha(f)$ is the attenuation frequency function, $S_{in}(f)$ and $S_{out}(f)$ are the amplitude spectra of pulse impinging the first interface of the phantom sample (at the input) and the amplitude spectra of pulse at the second interface of the phantom sample (at the output). The attenuation function is calculation as in [20]:

$$\alpha(f) = 20 \cdot \log_{10} \left(\frac{T_{01} \cdot R_{12} \cdot T_{10} \cdot |S_R(f)|}{R_{03} \cdot |S_2(f)|} \right), \quad (8)$$

where: R_{12} is the reflection coefficient from the interface sample – air, which is calculated from Z_1 and Z_2 impedances, T_{10} is the transmission coefficient through the interface sample – water, T_{01} – is the transmission coefficient at the interface water-sample, $|S_R(f)|$ and $|S_2(f)|$ are the amplitude spectra of the reference echo pulse $s_R(t)$ and the echo pulse from the phantom material output $s_2(t)$ respectively.

This experimentally registered function $\alpha(f)$ is suitable for attenuation coefficient estimation by linear fitting procedure. The attenuation coefficient linear fitting procedure estimates steepness level of the attenuation function at a particular frequency of interest. For example, in our case the attenuation coefficient at $f=2\text{MHz}$ is estimated using this expression:

$$\beta_{2\text{MHz}} = \frac{LLSA[\alpha(f)]}{2d(f_2 - f_1)}, \quad (9)$$

where $LLSA[*]$ is the linear least square approximation procedure; d is the estimated thickness of the phantom sample layer; $(f_2 - f_1)$ is the chosen frequency range in the bandwidth of the ultrasound transducer, so that the frequency of interest ($f=2\text{MHz}$) would be located in the center of the range. The attenuation coefficient β determines steepness level of the attenuation function at a particular frequency, therefore in our case we denominate the coefficient with the subscript 2 MHz as follows $\beta_{2\text{MHz}}$. In general, the β coefficient should increase with a frequency as the attenuation in some materials is a power-like frequency dependent function.

Description of hardware setup

Fig.4a shows the general view of the hardware used in experiments.

Investigation of reference and tissue like phantom materials is performed in a bottom - upwards direction. The ultrasound wave is excited at the bottom of the ultrasonic tract and reflects at the top of it. The ultrasonic tract is filled up with distilled water. On the top is placed

the reference reflector – stainless steel (see Fig. 4b). The reference setup will not be used in experiments, because reference echogram parameters are loaded for processing from a computer memory. Only the echogram signal from tissue like phantom material will be acquired on-line. An example of a tissue like phantom material is the layer of soybean oil on the top of distilled water. It can be seen in Fig.4c. There are a few of tissue like phantoms and attendee of the course does not know in *a-priori* which of phantoms he or she is investigating. The list of possible tissue like phantom materials with characteristic parameters is presented in didactic materials. The goal of the experiment is to recognize which one tissue like phantom material is under investigation.

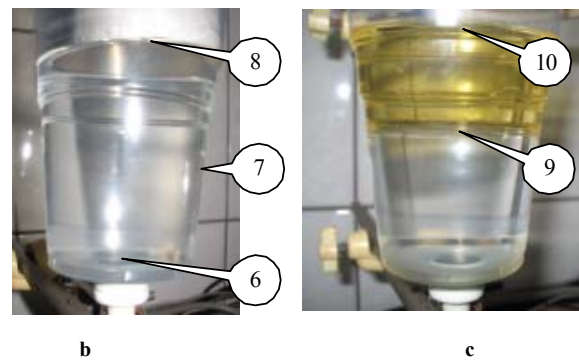
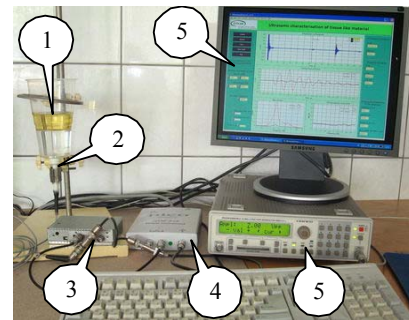

Fig. 4. General view of hardware setup (a), photos of reference materials structure (b), structure of tissue like material phantom (c).

The ultrasound pulses are sent and received using the transducer with the 2,25 MHz center frequency. The transducer is non-focused, with round aperture of $D=13\text{mm}$ in a diameter. The transducer is excited with a square unipolar pulse from the function generator HAMEG (HM8131-2) (HAMEG Instruments GmbH, Mainhausen, Germany). In the time diagram (Fig. 2), we can see that after loading the generator with a transducer the excitation pulse reshapes into damped periodic oscillation at the center frequency of electro-mechanical system – the ultrasound transducer. The function generator triggers the whole experimental system including the signal digitizer PICO ADC-212/100 (Pico Technology Ltd., Cambridgeshire, UK). The echographic signals are digitized using sampling rate of 100MHz and resolution 12 bits.

The digitizer and computer are connected via LPT (parallel) port. The IEEE-488 (GPIB) interface is used to

connect the function generator and a computer. All signal acquisition, processing and analysis is implemented in a software using the LabVIEW virtual instrument methodology and it is described in the next section.

Description of software implemented as a virtual instrument

The general view of the front panel of the virtual instrument is presented in Fig.5. The screen of the virtual instrument is divided into three main areas - columns. The left column of the screen area is dedicated for input parameters of the experiment. The buttons at the top of the left column control the execution of the virtual instrument. The middle of the left column is dedicated for input of parameters of reference materials and reference reflection. The data input cells at the bottom of the left column are to be filled with results of self-sustained calculations.

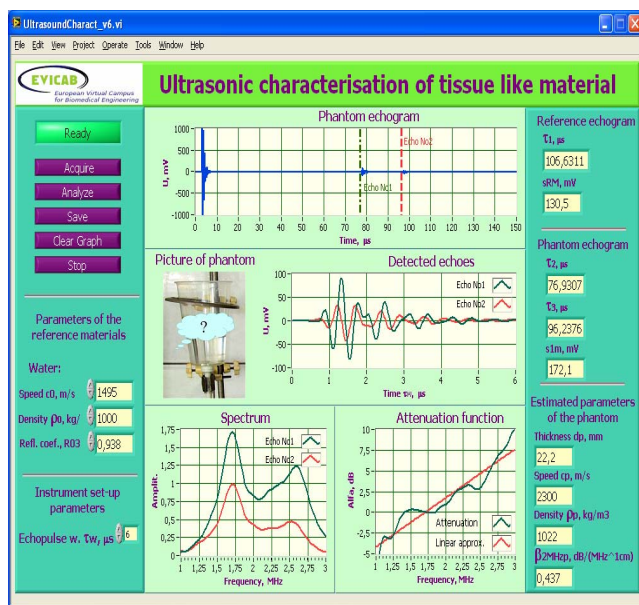

Fig. 5 The front panel of the virtual instrument

The panels in the center column of the screen are dedicated to display the intermediate results of experiments: signals and spectra. In the top diagram “Phantom echogram” the acquired waveform of echogram is displayed. The manual scroll markers are used to identify beginning instances of the first and the second echo pulses. The selected echo pulses are displayed in the diagram called “Detected echoes”. The diagram called “Spectrum” dedicated to display amplitude spectra of echo pulses. The “Attenuation function” diagram shows the registered attenuation frequency function.

The right column of the screen area is dedicated to indicate output parameters of experiments: parameters of echograms (“Reference echogram parameters”, “Phantom echogram parameters”) and phantom material characterizing parameters (“Estimated parameters of the phantom”).

The virtual instrument has its functional diagram, in which is realized hierarchy instrument control with buttons, the initial setup of the function generator, excitation pulse parameters, the initial setup of the signal

digitizer and digital echogram acquisition for further processing under the front panel. It is important to discuss processing algorithm applied for pulses in the echogram. The algorithm for ultrasound signal processing is presented in Fig.6.

First, in order to reduce noise, the acquired echogram was digitally filtered using Butterworth bandpass 2-nd order filter with $f_{low}=0,5$ MHz and high $f_{high}=3,5$ MHz cutoff frequencies. Then, echogram waveform passes through a time window beginning of which is manually adjusted using scroll markers. The time windowing selects the parts of the echogram belonging to echo pulses from anterior and posterior interfaces of the phantom sample.

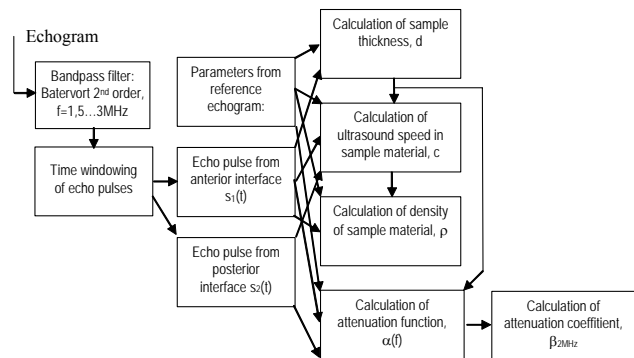

Fig. 6. The block diagram of the algorithm for ultrasound signal processing.

The waveforms of anterior and posterior pulses were used for calculation of the attenuation function in the frequency domain. In order to increase the frequency resolution, both waveforms were zero padded up to 4096 samples. The selected waveforms of echo pulses consist of 20 samples before beginning marker instance and are 128 samples long. Both echo pulse signals after FFT are represented as amplitude (not power) spectra. Then the logarithm of the attenuation function is calculated.

Discussion on pilot usage

The presented approach of the flexible controlled and interactive laboratory experiments was implemented and tested for the course of Ultrasound medical diagnostics in Biomedical engineering master program. The pilot usage of the system presented has shown that students were satisfied. Detailed learning materials for students were presented in the textbook [27] while electronic materials also are available from online e-Learning platform [28]. During laboratory work a student group have characterized parameters of phantom material during autumn semester 2007. Values of parameters estimated are provided in the Table 1 (cells in rows (E)) while reference materials parameters are given Table 1 (cells in rows (R)). The reference attenuation coefficient β_{2MHz} is extrapolated as by the method described in paper [27]. Other reference papers used for reference are also given in angle brackets (see Table 1).

The density of water sample is not identified, because the aluminum foil was used as a reflecting interface in the

water, therefore the echo pulse amplitude was not suitable for the purpose of water density estimation.

The practical implementations of ultrasonic tissue like material characterization made internationally at leading ultrasonic research laboratories [29, 30] show diverse opinions. The inter-laboratory comparison of material

Table 1. Summary of characterized parameters of materials in vitro

Phantom material		Speed of sound c , m/s	Density ρ , kg/m ³	Attenuation coefficient, β_{MHz} , dB / MHz ^{1.0} cm
Water (also used as filling liquid in all phantoms)	E	2244	—	0,02
	R [31]	1497	998	0,0096
Plexiglas (or PMMA - polymethyl-methacrylate)	E	3065	1460	0,1
	R [25]	2753	1190	0,94
Castor oil	E	1891	990	0,35
	R [25]	1511	969	1,84

characterization results made [29] for example comes to the following statement: “the major conclusion from this study is that uniformity does not exist among laboratories in terms of determination of fundamental ultrasonic properties in tissue like media”. This study also has shown that attenuation coefficient estimation is perhaps the most reliable, with small variation between sites. Regarding propagation speed values, the level of agreement is up to 1.7% [29].

We have to consider, that from the estimation point of view in these practical laboratory experiments we are not taking into account few factors influencing estimated data. Particularly, temperature of reference and phantom materials fluctuates in a room temperature range +(15...25)°C is not yet monitored, but assumed as a constant of +20°C; we assume also that ultrasound beam diffraction could be neglected at distances at (35...87) mm used in our experiments; the attenuation in the reference material – water was neglected in such low frequency (1...3) MHz range, while the attenuation is actually present and is coefficient estimated to be 0,0096 dB / (MHz¹ cm). So, the listed assumptions caused a limited precision in estimation of material properties.

Taking in account the main advantage of the system – flexibility – all corrections (more sophisticated echogram processing, corrections of errors, phantom sample improvement) could be quite easily introduced in the system. We plan to direct this task towards advanced students, capable with some supervision to modify the system.

Conclusion

Our main goal - to learn tissue like media characterization technology by practical experiments was achieved without great emphasis on the precision of estimations which could be improved in future. In this paper is presented only one system implementation example, but the same approach was applied in six other systems prototypes, which are described in textbook [27]

and also available for students. We found that required recourses for implementation are relatively low, as the suitable hardware equipment is standard and relatively inexpensive. But should be also noted that implementation of specific subject (e.g. Ultrasound medical diagnostics) in on-site and remotely controlled laboratory system is demanding work of collaborating experts. We think that such courseware implementations should be most efficient if at least one expert of ultrasound diagnostics and one expert of e-Learning platforms (e.g. Moodle and LabVIEW) would collaborate.

Since an approach was implemented and tested in the pilot laboratory work “Ultrasound characterization of tissue like material” in two cases: for on-site and remote experimenting, we could conclude that the developed system is integrated into teaching process and this achievement we present as a most important result.

The approach presented also is suitable for sharing experimental facilities among laboratories and institutions.

Acknowledgment

The research was supported by EU project EVICAB (contract No. 2005 – 3868/001 – 001) and Lithuanian state science and studies foundation.

References

1. Dewey John. Wikipedia http://en.wikipedia.org/wiki/John_Dewey.
2. Grober S., Vetter M., Eckert B. and Jodl H.-J. Experimenting from a distance—remotely controlled laboratory (RCL). Eur. J. Phys. 2007. Vol. 28. P. S127-S141.
3. Bertrand Y., Flottes M.-L., Azais F., Bernard S., Latorre L., Lorival R. A remote access to engineering test facilities for the distant education of European microelectronics students. Frontiers in Education. 6-9 Nov 2002. Vol. 1. P. T2E-24 - T2E-29.
4. Sanchez J., Dormido S., Pastor R., Morilla F. A Java/Matlab-based environment for remote control system laboratories: illustrated with an inverted pendulum. Education, IEEE Transactions on Aug. 2004. Vol. 47. Issue 3. P. 321 – 329.
5. Gao-Wei Chang; Zong-Mu Yeh; Hsiu-Ming Chang; Shih-Yao Pan. Teaching photonics laboratory using remote-control web technologies. Education, IEEE Transactions on Nov. 2005. Vol. 48. Issue 4. P. 642 – 651.
6. Almgren R. C., Cahow J. A. Evolving technologies and trends for innovative online delivery of engineering curriculum. Intern. J. Online Eng. 2005. Vol. 1. No. 1. <http://www.i-joe.org/ojs/include/getdoc.php?id=39&article=5&mode=pdf>
7. Bourne J., Harris D., Mayadas F. Online engineering education: learning anywhere, anytime. J. of Eng. Edu. January 2005. Vol. 94. No. 1. P. 131–146.
8. Garcia-Zubia J., Lopez-de-Ipina D., Hernandez U., Orduna P., Trueba I. An approach for WebLabs analysis. Intern. J. Online Eng. 2007. Vol. 3. No. 2. <http://www.i-joe.org/ojs/include/getdoc.php?id=374&article=119&mode=pdf>
9. Ewald H., Page G. S. Performing experiments by remote control using the internet. Global J. of Engng. Educ. 2000. Vol. 4. No. 3. P. 287-292.
10. Schmitz G., Ermert H., and Senge T. Tissue-characterization of the prostate using radio frequency ultrasonic signals. IEEE Trans. on Ultrason, Ferroel, and Freq. Control. January 1999. Vol. 46. No.1. P. 126– 138.
11. Pai-Chi Li and Sheng-Wen Huang. Ultrasound tomography of the breast using linear array. IEEE ICASSP. 2005. P. 989-992.
12. Hancock J. E., Cooke J. C., Chin D. T. and Monaghan M. J. Determination of successful reperfusion after thrombolysis for acute myocardial infarction: a noninvasive method using ultrasonic tissue

- characterization that can be applied clinically. *Circulation*. 2002. 105. P. 157-161.
13. **Yan Shi, Witte R. S. and O'Donnell M.** Identification of vulnerable atherosclerotic plaque using IVUS-based thermal strain imaging. *IEEE Trans. on Ultrason., Ferroel., and Freq. Control*. May 2005. Vol. 52. No.5. P. 844-850.
 14. **Negron L. A., Viola F., Black E. P., Toth C. A., Walker W. F.** Development and characterization of a vitreous mimicking material for radiation force imaging. *IEEE Trans. on Ultrason., Ferroel., and Freq. Control*. November 2002. Vol. 49. Issue 11. P. 1543 – 1551.
 15. **Vlad R. M., Czarnota G. J., Giles A., Sherar M. D., Hunt J. W., Kolios M. C.** High frequency ultrasound in monitoring liver suitability for transplantation. *Ultrasonics symposium*. 2004. *IEEE*. Aug. 2004. Vol. 2. 23-27. P. 830 – 833.
 16. **Njeh C. F., Fuerst T., Diessel E. and Genant H. K.** Review article: is quantitative ultrasound dependent on bone structure? *Osteoporos Int*. 2001. No. 12. P. 1–15.
 17. **Pellaumail B., Dewailly V., Watrin A., Loeuille D., Netter P., Berger G., Saied A.** Attenuation coefficient and speed of sound in immature and mature rat cartilage: a study in the 30-70 MHz frequency range. *Ultrasonics symposium. Proceedings IEEE*. Oct. 1999. Vol. 2. 17-20. P. 1361 – 1364.
 18. **Jirik R., Taxt T. and Jan J.** Ultrasound attenuation imaging. *J. Elec. Eng.* 2004. Vol.55. No.7-8. P. 180-187.
 19. **Zagzebski J. A., Gerig A., Chen Q, Tu H., Liu Wu., Varghese T. and Hall T.** Parametric imaging using a clinical scanner. *IEEE International ultrasonics, ferroelectrics and frequency control joint 50th anniversary conference*. 2004. P. 2165-2168.
 20. **Graciet C., Hosten B.** Simultaneous measurement of speed, attenuation, thickness and density with reflected ultrasonic waves in plates. *Ultrasonics symposium. Proceedings IEEE*. 1-4 Nov. 1994. Vol. 2. P. 1219 – 1222.
 21. **Adamowski J. C., Buiochi F. and Sigelmann R. A.** Ultrasonic measurement of density of liquids flowing in tubes., *Ultrasonics, ferroelectrics and frequency control*, *IEEE Transactions on* January 1998. Vol. 45. No. 1. P. 48 – 56.
 22. **Higuti R. T., Bacaneli F., Furukawa C. M. and Adamowski J. C.** Ultrasonic characterization of emulsions: milk and water in oil. *Ultrasonic symposium*. 1999. P. 779-782.
 23. **Ye S. G., Harasiewicz K. A., Pavlin C. J., Foster F. S.** Ultrasound characterization of normal ocular tissue in the frequency range from 50 MHz to 100 MHz. *Ultrasonics, ferroelectrics and frequency control*, *IEEE Transactions on* Jan. 1995. Vol. 42. Issue 1. P. 8 – 14.
 24. **Lee C. C., Lahham M., Martin B. G.** Experimental verification of the Kramers-Kronig relationship for acoustic waves. *Ultrasonics, ferroelectrics and frequency control*, *IEEE Transactions on* July 1990. Vol. 37. Issue 4. P. 286 – 294.
 25. **Ping He.** Experimental verification of models for determining dispersion from attenuation. *Ultrasonics, ferroelectrics and frequency control*, *IEEE Transactions on* May 1999. Vol. 46. Issue 3. P. 706 – 714.
 26. **Jurkonis R., Marozas V. and Kurapkienė S.** Development and evaluation of virtual instrument to supplement ultrasonic echoscope system for ophthalmology. *ISSN 1392-2114 Ultragarsas (Ultrasound)*. 2007. Vol.1(62). P. 12-17.
 27. **Jurkonis R., Marozas V., Lukoševičius A.** *Ultrasound medical diagnostics: practical lab works with virtual instruments (in Lithuanian)*. Kaunas: Technologija. 2007. ISBN: 978-9955-25-337-2.
 28. e-Learning platform „Ultrasound medical diagnostics: remote online laboratory“ implemented in Moodle. Is online using this link: <http://www.moodle.fi/evicab/moodle> after registration.
 29. **Madsen E. L., Dong F., Frank G. R., Garra B. S., Wear K. A., Wilson T., Zagzebski J. A., Miller H L., Shung K. K., Wang S.H, Feleppa E. J., Liu T., O'Brien W. D., Topp K. A., Sanghvi N. T., Zaitsev A. V., Hall T. J., Fowlkes J. B., Kripfgans O. D., Miller J. G.** Interlaboratory comparison of ultrasonic backscatter, attenuation, and speed measurements. *J. Ultrasound Med*. 1999. Vol.18. P.615–631.
 30. **Wear K. A., Stiles T. A., Frank G. R., Madsen E. L., Cheng F., Feleppa E. J., Hall C. S., Kim B. S., Lee P., O'Brien W. D., Oelze M. L. Jr., Raju B. I., Shung K. K., Wilson T. A and Yuan J. R.** Interlaboratory comparison of ultrasonic backscatter coefficient measurements from 2 to 9 MHz. *Journal of ultrasound in medicine*. 2005. No. 24. P. 1235-1250.
 31. CRC – Handbook of chemistry and physics. 45th ed., Chemical Rubber Company, Cleveland. OH. P. E-28.
 32. **Filipczynski L., Kujawska T., Tymkiewicz R. and Wojcik J.** Nonlinear and linear propagation of diagnostic ultrasound pulses. *Ultrasound in Med. & Biol*. 1999. Vol. 25. No.2. P. 285-299.

R. Jurkonis, V. Marozas, A. Lukoševičius

Mokomoji ultragarsinės medicininės diagnostikos kurso medžiaga: vietinių ir nuotolinių laboratorinių eksperimentų sistema

Reziumė

Darbo tikslas - vadovaujantis eksperimentinio mokymosi koncepcija sukurti ir įdiegti prototipinę laboratorinių eksperimentų sistemą į audinius panašioms medžiagoms apibūdinti.

Metodai. Laboratorinių eksperimentų sistemai įdiegti taikomos modernios elektroninio mokymosi technologijos, prototipinė sistema realizuota LabView virtualiųjų instrumentų ir mokymosi kurso valdymo aplinkos Moodle principais. Didėjantis ultragarsinių diagnostinių tyrimų poreikis, kai įvertinama kiekybinė informacija apie audinius, taip pat populiarėjanti ultragarsinė technologija medicinos praktikoje paskatino įdiegti modernią mokymosi sistemą biomedicininės inžinerijos studentams. Tuo siekiama jiems suteikti adekvačių ir modernių ultragarsinės technologijos taikymo medicinoje žinių.

Rezultatai. Išbandytos technologijos leido įdiegti ultragarsinės medicininės diagnostikos mokymosi medžiagą ir laboratorinius eksperimentus. Studentai atliko realius eksperimentus ir gavo į biologinius audinius panašių medžiagų parametrus, praktiškai pabandė taikyti ultragarsinio apibūdinimo principus. Biologinių audinių apibūdinimo teorija, kai kartu pateikiamas ir formulių išvedimas, ir iliustracijos, ir nurodomas darbo atlikimo eiliškumas, priinama studentams elektroninio mokymosi aplinkoje Moodle. Studentai gali pasitikrinti įgytas teorines žinias pagal interneto svetainėje pateiktus testus.

Išvados. Pagrindinis tikslas – per praktinius eksperimentus išmokti į audinius panašių medžiagų apibūdinimo technologijos - buvo pasiektas nekeliant uždavinio gauti didelį įvertinimo tikslumą. Tai gali būti ateities uždavinys. Straipsnyje pateiktas tik vienas sistemos įdiegimo pavyzdys, bet lygiai taip pat įdiegtos dar šešios prototipinės sistemos (jos aprašytos mokomojoje knygoje studentams). Manytume, kad įdiegimo išteklių reikia santykiškai mažų dėl to, kad tinkama aparatinė įranga yra standartinė ir santykiškai pigi. Aprašytoju būdu įdiegti galima iš kelių laboratorijų ar institucijų gautą laboratorinių eksperimentų įrangą. Bet kartu vertėtų pabrėžti, kad norint įdiegti vietinių ir nuotolinių laboratorinių eksperimentų sistemą į specializuotą (t.y. Ultragarsinės medicininės diagnostikos) mokymosi kursą, reikia specialistų pastangų. Toks darbas būtų labai veiksmingas, jeigu bendradarbiautų ultragarsinės technologijos ir elektroninio mokymosi platformų (Moodle ir LabView) specialistai. Pirmieji studentų laboratoriniai darbai, atlikti naudojantis vietiniu ir nuotoliniu eksperimento valdymu, leidžia teigti, kad sistema įdiegta į mokymo procesą ir tai svarbiausias rezultatas.

Pateikta spaudai 2008 01 28

DOI: 10.5755/j01.u.63.1.17062