

Diagnostic analysis of similar constructions of adaptive hydrodynamic bearings

V. Vekteris¹, A. Čereška², M. Jurevičius³

¹Vilnius Pedagogic University, Department of Technical Disciplines,
Studentų str. 39, LT-08106 Vilnius, Lithuania,

Phone: +370 5 2744734, Fax. +370 5 2745043, E-mail: vekteris@me.vgtu.lt

^{2,3}Vilnius Gediminas Technical University, Department of Machine Building,
Basanavičiaus str. 28, LT-03224 Vilnius, Lithuania,

Phone: +370 5 2370573, +370 5 2744734, Fax. +370 5 2745043,

E-mail: audrius@me.vgtu.lt, mindaugas.jurevicius@me.vgtu.lt

Abstract

Adaptive hydrodynamic bearings of two similar constructions with connective belts connecting segments are analyzed in this paper. Construction schemes of bearings are described and its analysis is carried out. From analysis of constructions of different bearings, qualities and defects are found. Analysis of possible tensions cases of connective belts and influence on shape of formation of hydrodynamic lubrication membrane is performed.

Analysis of experimental investigation is presented, vibrations parameters are obtained and influence of connective belts on a quality of the bearing work is ascertained.

Keywords: adaptive bearings, hydrodynamic bearings, rotor, bearings, segments, parameters, data.

Introduction

Rotors are basic elements of different energetic, electric, transport machines and of various instruments too, which provide transmission of a turning moment in it and moment of rotation. Performing important function in these systems they are sources of vibrations too which decrease stability of a rotor and are dependence on a construction of machine, its purpose, the type of bearing, frequency of a rotor rotation, nonaxiality of the rotor and bearing, etc. [1 - 6].

These undesirable lateral factors complicate regulation of characteristics of two rotor-bearing very much. Sledding bearings have a very big influence on a quality of work of a rotary system. Trying to minimize the instability of such systems, most diverse designs of bearings have been proposed on the basis of self-adjustment, including floating ring bearings, elliptical bearings, tilting-pad journal bearings and elliptical tilting pad journal bearings, as shown in Fig. 1. [1, 2]. Adaptive bearings show good results of work, so they are used in different components of various machines which operate with high speeds of rotation [10].

However, adaptive segmental bearings are damped insufficiently and they have a little productive power for uneven weighting of segments. When a rotor is horizontal, the lower segments are burdened more [7, 8]. Besides, assembly errors and adjustment procedures distort the initial geometry of a bearing, thus creating conditions for a non-uniform distribution of the load among the segments [9, 10].

Trying to avoid the aforesaid problems in radial bearings different means of segments regulation are used [11, 12].

Objects of researches

Adaptive hydrodynamic bearings with segments of two similar constructions are investigated (2a, 2b). These constructions are very similar and they differ only in that, that several elastic shoulders are connected segments in one construction (Fig. 2a), elastic ring that is moved easily and there are connected segments in another construction (Fig. 2b). The size of a radial clearance of the bearing, materials of bearing elements and construction of the bearing, are factors which determine its reliability of work.

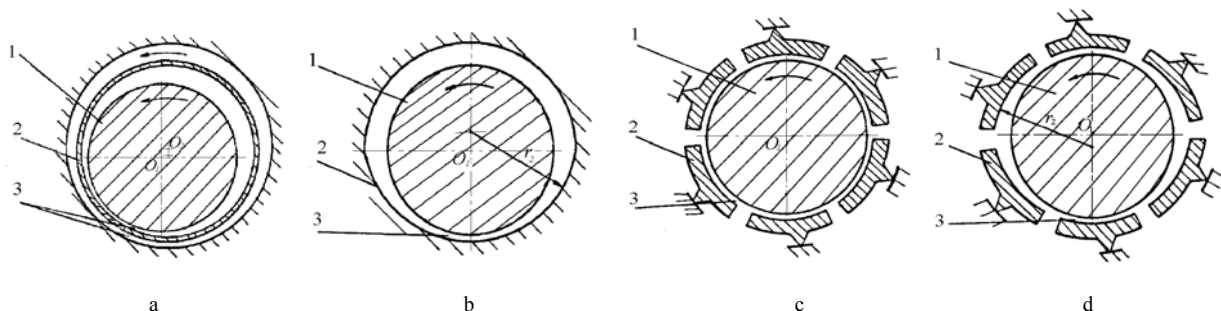

Fig. 1. Bearings : a – self-adjustment including floating ring bearings, b – elliptical bearings, c - tilting-pad journal bearings, d - elliptical tilting pad journal bearings; 1 - rotor, 2 - floating spacer or segment, 3 - carrying lubricating layer

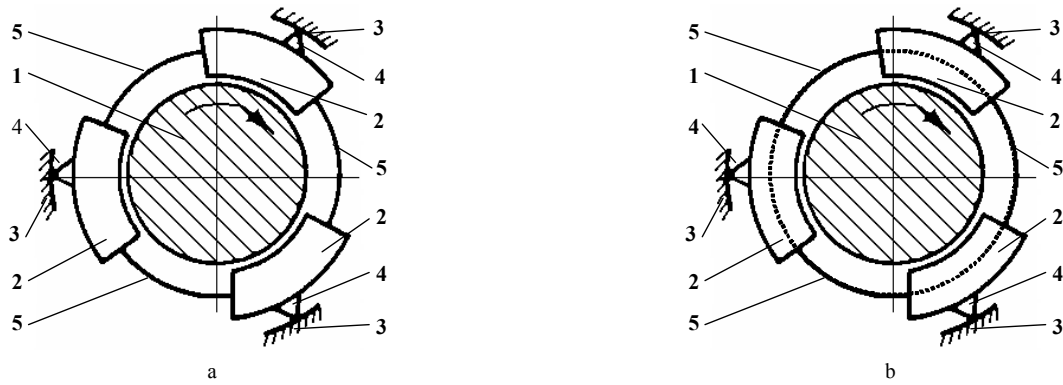

Fig. 2. Adaptive hydrodynamic bearings: a – elastic shoulders that are connected segments: 1 - rotor, 2 – segments 3 - spindle head 4 - adaptive thrust; 5 - elastic shoulders that are connected segments; b – with elastic ring that is moved easily and is connected segments: 1 - rotor, 2 – segments 3 - spindle head 4 - adaptive thrust, 5 - elastic ring

Analysis of constructions of adaptive hydrodynamic segmental bearings

Adaptive hydrodynamic segmental bearings possess with elastic elements that are connected segments.

The adaptive bearings with segments could be of different constructions, but big influence on a quality of bearing work is made by shoulders that are connected segments. There can be two cases (Fig. 3a, 3b) of influence on such shoulders [1].

The first case. In the first case (Fig. 3a) the systems stress is created by preloading the connecting bands by way of radial displacement of the supporting elements.

The bending moment and the normal force of bands assume the following value:

$$M_{0\varphi} = F_0 r_\Lambda \left[\frac{1}{\beta} - \frac{\cos\left(\frac{\beta}{2} - \varphi\right)}{2 \sin \frac{\beta}{2}} \right] \quad (1)$$

and

$$N_{0\varphi} = -\frac{F_0}{2 \sin \frac{\beta}{2}} \cos\left(\frac{\beta}{2} - \varphi\right), \quad (2)$$

where F_0 is the force from bearing elements applied to the segments; $\beta = \frac{2\pi}{n}$ is the fixed angle which determine the

position of the applied force F_0 ; n is the number of concentrated forces F_0 , φ is the current angle.

The displacement of the point of F_0 force application in relationship to the center of the bearing is determined by the following dependence:

$$u_{0r} = \frac{F_0 r_\Lambda^3}{EJ} \frac{1}{1 - \cos \beta} \left(\frac{\beta}{4} + \frac{1}{4} \sin \beta \frac{1 - \cos \beta}{\beta} \right) + \frac{F_0 r_\Lambda}{EF} \frac{1}{1 - \cos \beta} \left(\frac{\beta}{4} + \frac{\sin \beta}{4} \right), \quad (3)$$

where u_{0r} is the radial repositioning of segments at the point of the F_0 force application; F is the cross-section area of the bands; E is the modulus of elasticity; J is the moment of inertia; r_Λ is the radius of the median surface of the elastic bands (may be three values $r_\Lambda^2 > r_1 r_3$; $r_\Lambda^2 < r_1 r_3$; $r_\Lambda^2 = r_1 r_3$; where r_1 and r_3 are the inner and outer radii of a segment respectively).

The second case. In the second case the systems stress is created by the hydrodynamic pressure and temperature stress in the form of the existing moment M_{NT} (Fig. 3b), which includes temperature and hydrodynamic components. The moment of resistance of the band has the opposite direction. In this case the angle of rotation and the stress forces of the connecting bands can be determined by means of equations:

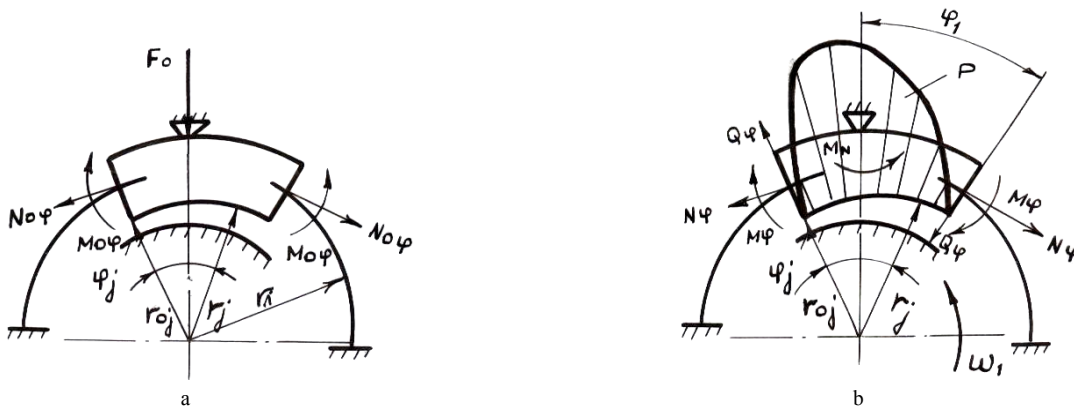

Fig. 3. Powers that are operated on segments of bearing: a – being preconceived weighting, b – being hydrodynamic pressure

$$\begin{aligned} & \frac{\partial^2}{r_y^2 \partial \varphi^2} \left(D \frac{\partial^2 u_r}{r_y^2 \partial \varphi^2} \right) + \frac{2}{r_y^2 \partial \varphi \partial z} \left[D(1-\nu) \frac{\partial^2 u_r}{\partial \varphi \partial z} \right] + \\ & + \frac{\partial^2}{\partial z^2} \left(D \frac{\partial^2 u_r}{\partial z^2} \right) = p - \frac{E h_y u_r}{(1-\nu^2) r_y^2} + \\ & + \frac{E h_y \alpha T_0}{(1-\nu^2) r_y} - \frac{\partial^2}{r_y^2 \partial \varphi^2} \left[D(1+\nu) \frac{\alpha \Delta T}{h_y} \right]. \end{aligned} \quad (4)$$

If moments of revolution are like 0, that Eq. 4 may be simplified:

$$\begin{aligned} & \frac{\partial^2}{r_y^2 \partial \varphi^2} \left(D \frac{\partial^2 u_r}{r_y^2 \partial \varphi^2} \right) + \frac{\partial^2}{\partial z^2} \left(D \frac{\partial^2 u_r}{\partial z^2} \right) = \\ & = p - \frac{E h_y u_r}{(1-\nu^2) r_y^2} + \frac{E h_y \alpha T_0}{(1-\nu^2) r_y} - \\ & - \frac{\partial^2}{r_y^2 \partial \varphi^2} \left[D(1+\nu) \frac{\alpha \Delta T}{h_y} \right]. \end{aligned} \quad (5)$$

The rotation angle of segments should be checked according to the following equation:

$$\frac{\partial \Theta_n^{(j)}}{\partial \varphi} = r \Lambda \frac{M_{NT}^{(j)}}{EJ}, \quad (6)$$

where Θ_n is the angle of rotation of the j -th segment; EJ is the bending rigidity of the bands. Hence

$$\begin{aligned} \Theta_n^{(j)}(\varphi) &= \Theta_{n0}^{(j)} + \\ & + r \Lambda \int_0^{\varphi_c} \frac{M_{NT}^{(j)}(\varphi) d\varphi}{EJ(\varphi)}; \Theta_{n0}^{(j)} = \Theta_n^{(j)}(0), \end{aligned} \quad (7)$$

where Θ_{n0} is the initial angle of rotation of the j -th segment due to preliminary deformation of the bands by the force F_0 .

The momentary values of the functions, which express hydrodynamic moments, are calculated by integrating the pressure of the supporting lubricant layer across the surface of the segments with the help of the following expression:

$$M_n^{(j)} = -r_2 r_3 \int_{-L}^{\frac{L}{2}} \int_0^{\varphi_c} p(\varphi, z) \sin(\varphi - \varphi_1) d\varphi dz, \quad (8)$$

where L is the length a segment; φ_c is the angular boundary of the segments exit edge; P is the hydrodynamic pressure; φ_1 is the angular coordinate of the center of support of the segment.

Rigidity of connective shoulders of segments is proportional directly to the hydrodynamic pressure and inversely proportional to the angle of turning segments.

Adaptive hydrodynamic bearings with elastic ring that is moved easily.

The principal scheme of the adaptive hydrodynamic bearing is given in Fig. 4.

There are possible four cases of such bearing loading.

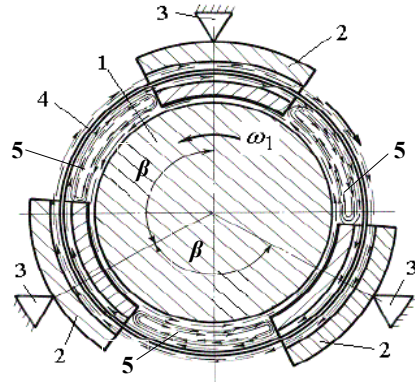

Fig. 4. Adaptive hydrodynamic bearing with elastic ring that is moved easily and is connected segments 1 – rotor, 2 – segments, 3 – adaptive thrust, 4 – elastic ring, 5 – lubricant

The first case. If no load is applied to the rotating cylinder then the equations of motion in the forces for free undamped vibrations will take the form:

$$\begin{vmatrix} m_y \ddot{y} \\ 0 I_y \ddot{\varphi} \end{vmatrix} + \begin{vmatrix} C_y 0 \\ 0 C_\varphi \end{vmatrix} \begin{vmatrix} y \\ \varphi \end{vmatrix} = \begin{vmatrix} 0 \\ 0 \end{vmatrix}, \quad (9)$$

where m_y, I_y are the mass of the moving elastic element and its polar moment of inertia; C_y, C_φ – rigidity by coordinates y, φ . The angular frequencies of vibration are determined in the usual way:

$$\omega = \sqrt{\frac{C_y}{m_y}} \quad \text{and} \quad \omega_\varphi = \sqrt{\frac{C_\varphi}{I_y}}, \quad (10)$$

where $I_y = 2m_y r_y^2$.

The vibration amplitudes and initial phases are determined by the initial conditions: $y = y_0, \varphi = \varphi_0$ and $V = V_0, \omega = \omega_0$ under $t = 0$:

$$A_y = \sqrt{\frac{y_0^2 + V_0^2}{\omega_y^2}} \quad \text{and} \quad A_\varphi = \sqrt{\frac{\varphi_0^2 + \omega_0^2}{\omega_\varphi^2}}, \quad (11)$$

$$\alpha_y = \arctg \frac{\omega_y}{V_0} y_0 \quad \text{and} \quad \alpha_\varphi = \arctg \frac{\omega_\varphi}{\omega_0} \varphi_0, \quad (12)$$

where y_0, φ_0 are the initial displacements; V_0, ω_0 are the initial velocities; t is the time.

The second case. If a turbulent force acts on the elastic cylinder only in one segment, the forced undamped vibrations will be described by the following equations:

$$\begin{vmatrix} m_y \ddot{y} \\ 0 I_y \ddot{\varphi} \end{vmatrix} + \begin{vmatrix} C_y 0 \\ 0 C_\varphi \end{vmatrix} \begin{vmatrix} y \\ \varphi \end{vmatrix} = \begin{vmatrix} Q_y \\ M_\varphi \end{vmatrix}. \quad (13)$$

When the elastic cylinder is suspended in all segments (Fig. 4) the equations of motion will take on the form:

$$\begin{vmatrix} m_y \ddot{x} \\ 0 m_y \ddot{y} \end{vmatrix} + \sum_{i=1}^n C_i \begin{vmatrix} \cos^2 \alpha_i \sin \alpha_i \cos \alpha_i \\ \sin \alpha_i \cos \alpha_i \sin^2 \alpha_i \end{vmatrix} \begin{vmatrix} x \\ y \end{vmatrix} = \begin{vmatrix} Q_x \\ Q_y \end{vmatrix}. \quad (14)$$

The frequency of forced vibrations under the effect of harmonic forces $Q_y = Q_0 \sin \omega_y t$ and $M_\varphi = M_0 \sin \omega_y t$ can be presented in the following form:

$$\omega_y = \omega_y \sqrt{1 - \frac{1}{k_{g0}}} \text{ and } \omega_\varphi = \omega_y \sqrt{1 - \frac{1}{k_{g0}}} \quad (15)$$

where k_{g0} is the dynamic coefficient. In the given case under $k_{g0} \rightarrow \infty$ $\omega_y = \omega_y = \omega_\varphi$, i.e., the natural frequency is coincident with the frequency of the forced vibrations.

The third case. If no load is applied to the elastic cylinder, then its free vibrations under viscous damping are determined by the following equations of motion:

$$\begin{vmatrix} m_y 0 \\ 0 I_y \end{vmatrix} \begin{vmatrix} \ddot{y} \\ \ddot{\varphi} \end{vmatrix} + \begin{vmatrix} H_y 0 \\ 0 H_\varphi \end{vmatrix} \begin{vmatrix} \dot{y} \\ \dot{\varphi} \end{vmatrix} + \begin{vmatrix} C_y 0 \\ 0 C_\varphi \end{vmatrix} \begin{vmatrix} y \\ \varphi \end{vmatrix} = 0, \quad (16)$$

where H_y and H_φ are the coefficients of viscous damping.

Angular frequencies are determined in the usual way:

$$\omega_y^* = \sqrt{\frac{C_y}{m_y} - \left(\frac{H_y}{2m_y}\right)^2} \text{ and } \omega_\varphi^* = \sqrt{\frac{C_\varphi}{I_y} - \left(\frac{H_\varphi}{2I_y}\right)^2}. \quad (17)$$

The influence of a viscous damping on the frequency is minor, therefore, the availability of viscous resistance can be disregarded while calculating the natural frequency of the elastic cylinder or ring. The amplitudes A_y, A_φ and the phase angles α_y, α_φ are obtained from the initial conditions in the usual way. Instead of expressions (11) and (12) we obtain:

$$A_y = \sqrt{y_0^2 + \frac{\left(u_0 + \frac{H_y}{2m_y} y_0\right)^2}{\left(\frac{C_y}{m_y}\right)^2 - \left(\frac{H_y}{2m_y}\right)^2}},$$

$$\alpha_y = \arctg \frac{y_0 \omega_y^*}{u_0 + \frac{H_y}{2m_y} y_0}, \quad (18)$$

$$A_\varphi = \sqrt{\varphi_0^2 + \frac{\left(\omega_0 + \frac{H_\varphi}{2I_y} \varphi_0\right)^2}{\left(\frac{C_\varphi}{I_y}\right)^2 - \left(\frac{H_\varphi}{2I_y}\right)^2}},$$

$$\alpha_\varphi = \arctg \frac{\varphi_0 \omega_\varphi^*}{\omega_0 + \frac{H_\varphi}{2I_y} \varphi_0}. \quad (19)$$

The fourth case. When the elastic cylinder is under the effect of perturbation in tangential openings of each segment, the forced vibrations under viscous damping are determined by the following equations of motion:

$$\begin{vmatrix} m_y 0 \\ 0 m_y \end{vmatrix} \begin{vmatrix} \ddot{x} \\ \ddot{y} \end{vmatrix} + \sum_{i=1}^n C_i \begin{vmatrix} \cos^2 \alpha_i \sin \alpha_i \cos \alpha_i \\ \sin \alpha_i \cos \alpha_i \sin^2 \alpha_i \end{vmatrix} \begin{vmatrix} \dot{x} \\ \dot{y} \end{vmatrix} + \sum_{i=1}^m C_i \begin{vmatrix} \cos^2 \alpha_i \sin \alpha_i \cos \alpha_i \\ \sin \alpha_i \cos \alpha_i \sin^2 \alpha_i \end{vmatrix} \begin{vmatrix} x \\ y \end{vmatrix} = \begin{vmatrix} Q_x \\ Q_y \end{vmatrix}. \quad (20)$$

In the same way the equation of motion for angular coordinates in the matrix expression takes on the following form:

$$\begin{vmatrix} I_y 0 \\ 0 I_y \end{vmatrix} \begin{vmatrix} \ddot{\varphi} \\ \ddot{\Theta} \end{vmatrix} + \sum_{i=1}^n H_{\Theta i} \begin{vmatrix} \cos^2 \alpha_i \sin \alpha_i \cos \alpha_i \\ \sin \alpha_i \cos \alpha_i \sin^2 \alpha_i \end{vmatrix} \begin{vmatrix} \dot{\varphi} \\ \dot{\Theta} \end{vmatrix} + \sum_{i=1}^m C_{\Theta i} \begin{vmatrix} \cos^2 \alpha_i \sin \alpha_i \cos \alpha_i \\ \sin \alpha_i \cos \alpha_i \sin^2 \alpha_i \end{vmatrix} \begin{vmatrix} \varphi \\ \Theta \end{vmatrix} = \begin{vmatrix} M_\varphi \\ M_\Theta \end{vmatrix}, \quad (21)$$

where $H_{\Theta i}$ and $C_{\Theta i}$ are the coefficients of viscous damping by coordinates φ and Θ . The perturbation frequency under the effect of harmonic forces and moments takes on the following form:

$$\omega_{yi} = \omega_i \left[\frac{2\xi_i - 1}{1 - \frac{1}{k_{g0i}}} \right]^{-\frac{1}{2}}, \quad (22)$$

where $i = x, y, \Theta$; $\xi_i = \frac{H_i}{2\sqrt{m_i C_i}}$.

Experimental results of measurement and its analysis

Experimental investigation of given bearings (Fig. 2) was carried out for the second case of bearings loading, and of the given bearings (Fig. 2b) for the first case of bearings loading.

Results of experimental measurements are given in Fig. 5, 6, 7, 8. Results of vibrochange measurements of adaptive hydrodynamic bearings with segments that are connected with several elastic shoulders are shown in Fig. 5 and 7, and results of vibrochange measurements of segments that is connected elastic ring which is moved easily in Fig. 6 and 8.

From the results of vibrochange measurements one can see, that amplitudes of vibrochanges of adaptive hydrodynamic bearings with elastic shoulders that are connected segments are decreased with increasing frequency of a rotor rotation (Fig. 5, 7) and amplitudes of vibrochanges of bearings with the elastic ring that is moved easily and is connected segments is increased with increasing frequency of a rotor rotation (Fig. 6, 8). When the frequency of a rotor rotation is 2984 rpm (Fig. 5), the vibrochange signal amplitude in the horizontal direction is 12 μm , the vibrochange signal amplitude in the vertical direction is 16 μm and when the frequency of a rotor rotation is 4025 rpm (Fig. 7) the vibrochange signal amplitude in the horizontal direction is 3 μm and in the vertical direction is 4 μm . When the frequency of a rotor rotation is 2994 rpm (Fig. 6) the vibrochange signal amplitude in the horizontal direction is 7 μm and in the vertical direction is 7 μm and when the frequency of a rotor rotation is 4030 rpm (Fig. 8) the vibrochange signal amplitude in the horizontal direction is 16 μm and in the vertical direction is 22 μm .

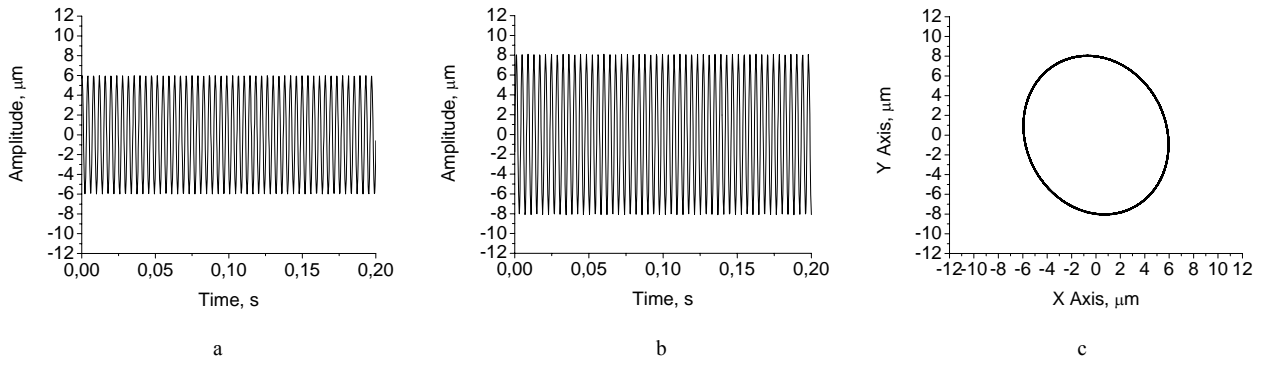

Fig. 5. Adaptive hydrodynamic bearings with several shoulders that are connected segments, when frequency of rotor rotation is 2984 rpm: a – signal of vibrochange in the horizontal direction, b - signal of vibrochange in the vertical direction, c – orbit.

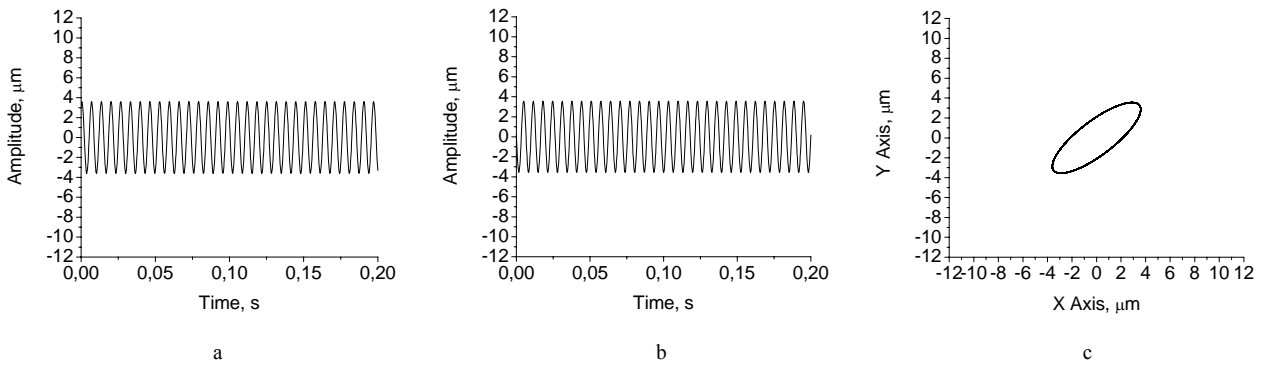

Fig. 6. Adaptive hydrodynamic bearings with elastic ring that is moved easily, when frequency of rotor rotation is 2994 rpm: a – signal of vibrochange in the horizontal direction, b - signal of vibrochange in the vertical direction, c – orbit.

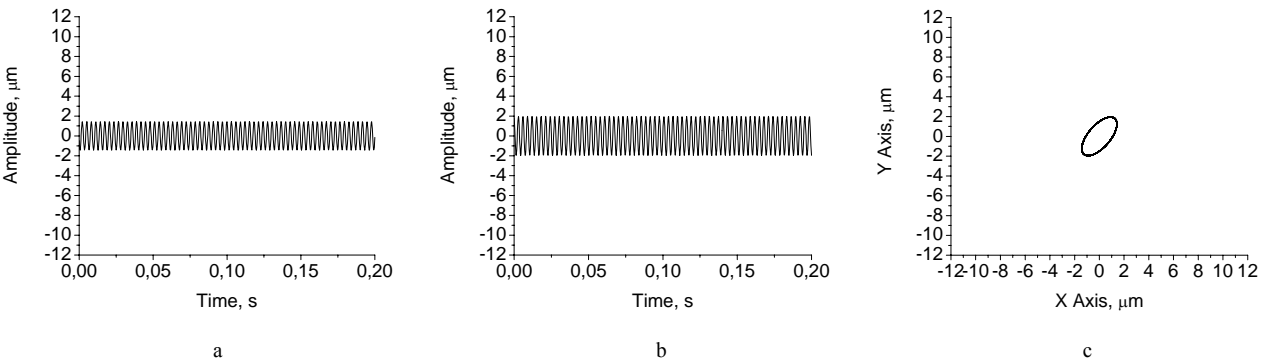

Fig. 7. Adaptive hydrodynamic bearings with several shoulders that are connected segments, when frequency of rotor rotation is 4025 rpm: a - signal of vibrochange in the horizontal direction, b - signal of vibrochange in the vertical direction, c – orbit

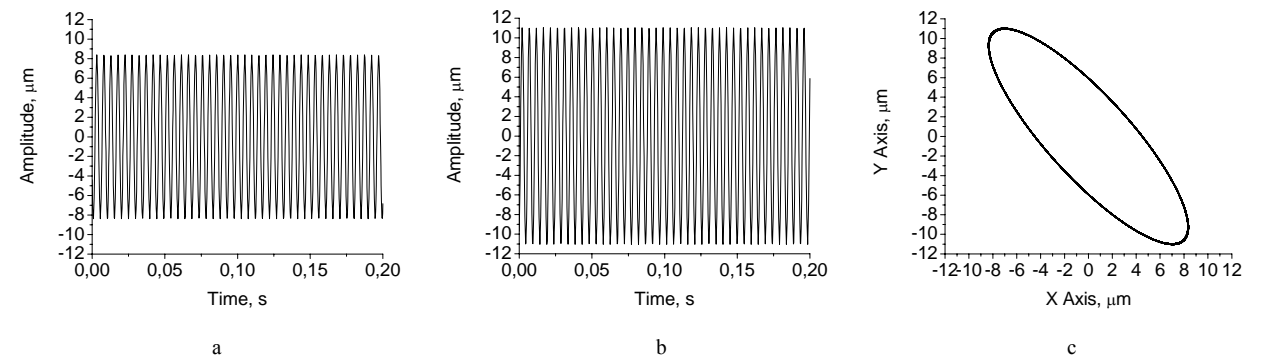

Fig. 8. Adaptive hydrodynamic bearings with elastic ring that is moved easily, when frequency of rotor rotation is 4030 rpm: a - signal of vibrochange in the horizontal direction, b - signal of vibrochange in the vertical direction, c – orbit

Parameters of rotor rotation orbits in adaptive hydrodynamic bearings are varied too. The diameter of the orbit of adaptive hydrodynamic bearings with elastic shoulders that are connected segments is increased with a decreasing frequency of a rotor rotation (Fig. 5, 7) and the orbit of a rotor rotation is decreased with a decreasing frequency of a rotor rotation, rotating rotor in the bearings of elastic collar that is moved easily and is connected segments (Fig. 6, 8).

Conclusions

Results of the investigation have shown, that adaptive bearings with elastic shoulders connect segments are more stiff and the rotor is rotated more precise in it than in bearings with an elastic ring that is moved easily and is connected to segments.

Adaptive hydrodynamic bearings with an elastic ring that is moved easily and is connected to segments may be used when the rotary system is working at the resonant frequency, because the ring is supposed to suppress vibrations, but it is necessary to carry out additional experimental investigation in order to confirm it.

References

1. **Vekteris V. J.** Adaptive tribological systems. Theory and application. Scientific publications. Vilnius: Technique. 1996. P. 203.
2. **Barzdaitis V., Činikas G.**: Monitoring and diagnostic of rotor machines. Kaunas: Technology. 1998. P. 364.
3. **Lipowsky G., Solyomvari K., Varga G.** Vibration testing of machines and their maintenance. Amsterdam: Elsevier Science Publishers. 1990. P. 303.
4. **Bently D. E., Hatch Ch. T.** Fundamentals of rotating machinery diagnostics. Bently Pressurized Bearing Company. Printed in Canada. First printing. 2002. P. 725.
5. **Muszynska A.** Vibrational diagnostics of rotating machinery malfunctions. International Journal of Rotating Machinery. USA. 1995. Vol.1. No. 3-4. P. 237-266.
6. **Bently D. E.** Rotating machinery measurements 101. Orbit, USA. 1994. Vol.15. No. 2. P. 4-6.
7. **Karnopp D. C., Margolis D. L., Rosenberg R. C.** System dynamics: A unified Approach, 2-nd ed. USA. John Wiley and Sons. Inc. 1990. P. 514.
8. **Childs D.** Turbomachinery rotordynamic. Phenomena, modeling and analysis. J. Wiley & Sons. Inc. New York. 1993. P. 476.
9. **Čereška A., Vekteris V.** Analytical research of hydrodynamic bearings in mechatronical systems. Solid State Phenomena / Trans tech publications LTD. 2005. Vol.113. P. 383-387.
10. **Vekteris V., Čereška A.** Diagnostics of functioning quality of the systems with sliding bearings. Mechanika. Kaunas: Technology. 2002. No. 2. P. 51-56.
11. **Čereška A.** Complex of experimental research of tribological systems. Journal of Vibroengineering. 2005. Vol. 7. No. 4. P. 28 – 32.
12. **Barzdaitis V., Činikas G.** Condition monitoring data formats used in rotating machinery diagnostics. Mechanika. Kaunas: Technology. 1997. No. 2. P. 40-48.

V. Vekteris, A. Čereška, M. Jurevičius

Panašių konstrukcijų adaptyviųjų hidrodinaminių guolių diagnostinė analizė

Reziumė

Tiriami adaptyvūs dviejų panašių konstrukcijų hidrodinaminiai guoliai su skirtingais segmentus jungiančiais elementais. Aprašytos guolių konstrukcinės schemos, atlikta jų analizė, nustatyti pranašumai ir trūkumai. Atlikta segmentų jungiamųjų juostų galimų įtempimų atvejų analizė, taip pat eksperimentinė diagnostinė analizė, gauti virpesių parametrų duomenų formatai ir nustatyta segmentus jungiančių skirtingų elementų įtaka guolio darbo kokybei. Tyrimų rezultatai apibendrinti ir padarytos išvados.

Pateikta spaudai 2008 09 16

DOI: 10.5755/j01.u.63.3.17079