

A study of the design and the radiation patterns of rectangular bimorph acoustic transducers with thin piezoelectric ceramic plates

A. Petrauskas

Prof. K. Baršauskas Ultrasound Institute

Kaunas University of Technology

Studentų st. 50, LT-51368 Kaunas, Lithuania

E-mail: Algimantas.Petrauskas@ktu.lt

Abstract

In this article, the design of asymmetric bimorph piezoelectric ceramic transducer with loose and fixed edges and with parallel electric excitation is studied. Rectangular piezoelectric ceramic transducers in flexural vibration with straight and parallel nodal lines of vibration are studied. The transducer's radiation in a plane perpendicular to the surface of the transducer and parallel to the nodal lines of vibrations is examined. By using the classic theory, the radiation patterns of such transducers are evaluated. The radiation pattern of the transducer is evaluated in a plane, perpendicular to the direction of flexural vibration of the nodal lines. In another perpendicular plane the radiation pattern of the transducer is calculated the same as for an oscillating piston. Diagrams to calculate these radiation patterns are supplied. It is mentioned that for effective operation of such transducers vibrations of the piezoelectric ceramic plate arrays with the vibrations of elastic plates, on which the arrays are mounted, must be matched. It is noted, that when calculating the radiation patterns of simple bimorph rectangular transducers, the expressions of the transducer's flexural vibration mode must be evaluated. When calculating radiation patterns of multi-component rectangular transducers, the distribution of vibrations on the transducer's surface can be evaluated as harmonic. It is noted, that the angle between a normal to a flat transducer's surface and direction of radiation depends on the acoustic wavelength ratio in the transducer and the working environment. The value of this angle can change by small amounts, dependant on the operating frequency. A design of a unidirectional acoustic antenna, consisting of an array of four such transducers is presented.

Keywords: piezoelectric ceramic transducer, piezoelectric ceramic plate, radiation pattern, flexural vibration, nodal lines of flexural vibration, parallel nodal lines, design of piezoelectric transducers

Introduction

The working conditions of a solid electroacoustic transducer when it is operating in a gas environment differ greatly from working conditions when such transducer operates in liquids and solid materials. This is because the acoustic impedance of gas is respectively 10^3 and 10^4 times less than the acoustic impedance of liquids and solids [1]. Therefore, electroacoustic transducers, which can effectively produce ultrasonic radiation in liquids and solids, radiate about 10^3 times less energy into gas.

At present times, piezoelectric ceramic transducers in longitudinal vibration with matching layers and transducers in flexural vibration are both used in a gas environment [2-31]. The usage of transducers in a flexural mode gives the best possibility to match acoustic impedances of air and the transducer, because flexural transducers have sufficiently low acoustic impedance. Such transducers have a solid radiating surface and therefore are resistant to the effects of the aggressive gas environment. Because of this, the application of these transducers in gas environments is very promising and is currently being widely investigated.

Alongside various transducer designs with flexural vibrations, the piezoelectric ceramic rectangular thin-plate transducer in flexural vibration can be used [32-45]. It is promising to use this type of the transducer to develop various measurement applications in a gas environment. As will be mentioned below, the required radiation patterns of these rectangular transducers can be easily obtained.

The required radiation patterns are obtained when nodal lines of vibrations on the surface of the rectangular transducer are straight and parallel to one another [32-34]. In this case, the transducer's radiation in a plane perpendicular to the surface of the transducer and parallel to the nodal lines of vibrations is the same as an acoustic field generated by an oscillating piston. In a perpendicular plane, if flexural transducer is flat, the transducer reveals a two-leaf radiation pattern and the inclination angle α between the surface of the transducer and a plane, perpendicular to the direction of radiation. This angle depends on a ratio of acoustic wavelength in transducer and in air [32]:

$$\alpha_{1,2} = \pm \arcsin \frac{k_s \lambda_a}{2l}, \quad (1)$$

where α is the angle between the surface of the transducer and a plane, perpendicular to the direction of radiation; λ_a – the acoustic wavelength in air; k_s – the number of nodal lines in a transducer; l is the length of a transducer in the direction of flexural vibrations.

Various authors propose a variety of designs for such transducers [1,2,5-10,27,28,32,34,37,41,45,46].

Designs of transducers in flexural vibration

In our opinion, it is convenient in practice to use transducers when flexural vibrations are excited in them by transversal or longitudinal displacement. It is preferred that these displacements should be distributed on the entire surface of the transducer. When exciting flexural vibrations in this way, the piezoelectric ceramic transducer

has a high efficiency, comparatively small dimensions and low weight.

The design of such transducer [34] is presented in Fig. 1.

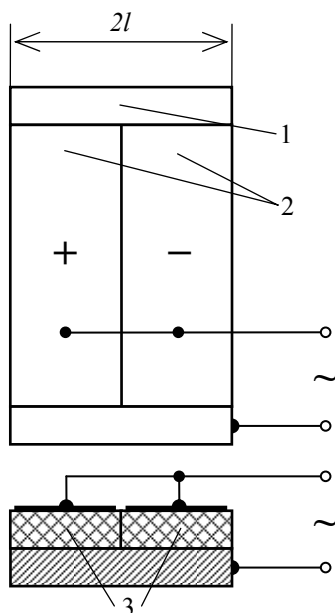

Fig.1. Asymmetric bimorph piezoelectric ceramic transducer (width $2l$) with loose edges and with parallel electric excitation: 1 – thin rectangular elastic (metal) plate; 2 – electrodes; 3 – piezoelectric ceramic plates with opposite polarization

The piezoelectric transducer (Fig. 1) consists of two rectangular piezoelectric ceramic plates of opposite polarization. The plates are mounted on a thin rectangular elastic (metal) plate. When electric pulses are supplied to the electrodes attached to the piezoelectric ceramic plates, flexural vibrations with opposite phases are being excited in each ceramic plate. The elastic plate radiates the vibration of the transducer into a gas environment. When piezoelectric plates are identical, a nodal line of flexural vibration is always present at their juncture and the vibrations of the transducer are symmetric to the juncture line.

In such transducer, the nodal lines of flexural vibration are distributed parallel to the length of the transducer. At the lowest resonance frequency, one nodal line of flexural vibration is distributed transversely to the surface of the transducer. It can be seen in practice when observing Chladni figures on the transducer's surface (Fig. 2 and 3).

As seen from Fig. 2, the piezoelectric ceramic transducer has a resonance frequency at the first mode (Fig. 2a) of flexural vibration transversely to the surface of the transducer at the frequency of 13.96 kHz and a resonance frequency of the second mode (Fig. 2b) of flexural vibration at the frequency of 34.91 kHz.

From Fig. 2a one can also see that along the transducer's surface the second mode of flexural vibration is located. In this case, the vibrations of the transducer are very complex, the radiation pattern has a complex form and therefore is not suitable to use for measurements.

From Fig. 2b one can see that along the transducer's surface, flexural vibrations have the same phase. Because of that, such transducer has a two-leaf radiation pattern. These vibrations of the transducer could be used when

designing acoustic antennas with two-leaf or one-leaf radiation patterns of different widths. These antennas can be used for various measurements in a gas environment.

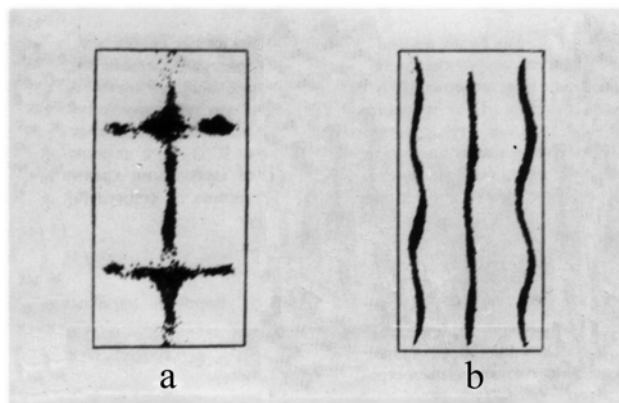

Fig.2. Chladni figures on the surface of the transducer (Fig. 1), consisting of an aluminum plate (measuring 70x32x2 mm) and two piezoelectric ceramic plates (measuring 60x16x2 mm): a – frequency is 13.96 kHz; b – frequency is 34.91 kHz

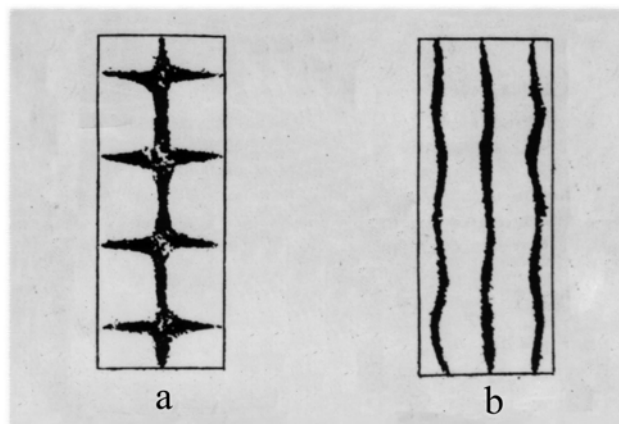

Fig.3. Chladni figures on the surface of the transducer (Fig. 1), consisting of an aluminum plate (measuring 70x26x2 mm) and two piezoelectric ceramic plates (measuring 60x13x1.5 mm): a – frequency is 28.12 kHz; b – frequency is 60.01 kHz

It needs to be noted that in such design of the transducer, the excitation of longitudinal and transversal vibrations on the transducer's surface is avoided. This simplifies the usage of the transducer when it is excited by using electrical pulses. In such transducer no other than flexural vibrations are excited.

In Fig. 4, the shape of the second mode of flexural vibration transversely to the surface of the transducer presented in Fig. 1 is shown.

After choosing special dimensions of piezoelectric ceramic plates and elastic plate, resonance flexural vibration can be excited in the elastic plate, fixed on a rectangular frame along the whole perimeter. The design of such transducer is given in Fig. 5.

The piezoelectric transducer (Fig. 5) consists of two rectangular piezoelectric ceramic plates of opposite polarization. The plates are mounted on a thin rectangular elastic plate, which is fixed on a rectangular frame along the whole perimeter. When electric pulses are supplied to

the electrodes of piezoelectric ceramic plates, flexural vibrations with opposite phases are being excited in each ceramic plate. When piezoelectric plates are identical, a nodal line of flexural vibration is always present at their juncture and the vibrations of the transducer are symmetric to the juncture line.

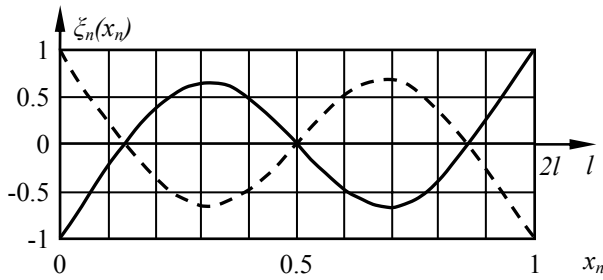

Fig.4. The shape of the second mode of flexural vibration transversely to the surface of the transducer (Fig. 1) (normalized value)

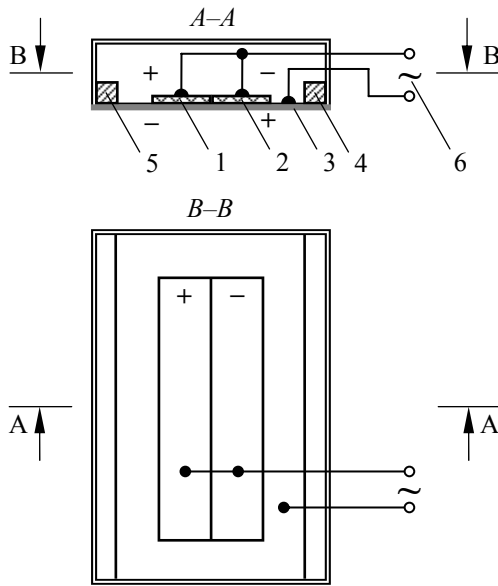

Fig.5. Asymmetric bimorph piezoelectric ceramic transducer with fixed edges and with parallel electric excitation: 1, 2 – piezoelectric ceramic plates with opposite polarization; 3 – rectangular elastic plate; 4, 5 – rectangular frame; 6 – electric excitation

In this transducer, the nodal lines of flexural vibration are distributed parallel to the length of the transducer's surface. At the lowest resonance frequency, three nodal lines of flexural vibration are distributed transversely to the surface of the transducer. It can also be seen in practice when observing Chladni figures on the transducer's surface (Fig. 6).

One can see from Fig. 6, that the piezoelectric ceramic transducer has the resonance frequency of the third mode (Fig. 6a) of flexural vibration transversely to the surface of the transducer at the frequency of 5.81 kHz and the resonance frequency of the fifth mode (Fig. 6b) of flexural vibration at the frequency of 28.76 kHz.

From Fig. 6a and 6b one can see that along the transducer's surface, flexural vibrations have the same phase. Because of that, this transducer also has a two-leaf

radiation pattern like a transducer with loose edges shown in Fig. 1. These vibrations of the transducer could also be used when designing acoustic antennas with two-leaf or one-leaf radiation patterns of different widths.

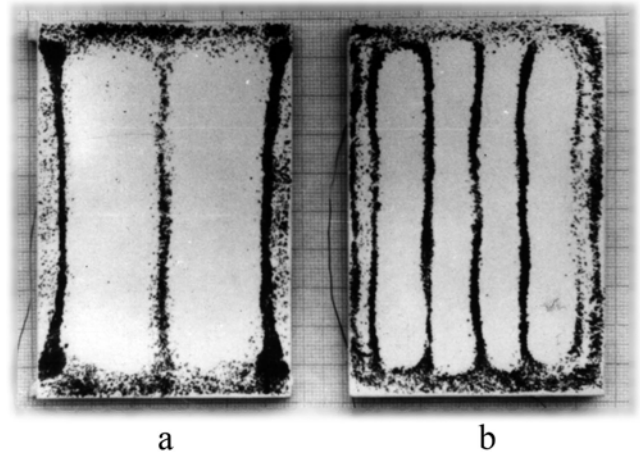

Fig.6. Chladni figures on the surface of the transducer (Fig. 5), consisting of elastic (aluminum) plate (measuring 87.0x54.8x1.5 mm) fixed on a rectangular frame along the whole perimeter and two piezoelectric ceramic plates (measuring 60x15x1.5 mm): a – the frequency is 5.81 kHz; b – the frequency is 28.76 kHz

In such design of the transducer, the excitation of longitudinal and transversal vibrations on the transducer's surface is also avoided.

In Fig. 7, the shape of the fifth mode of flexural vibration transversely to the surface of the transducer with elastic plate fixed on a rectangular frame is presented.

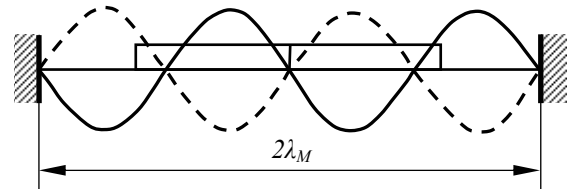

Fig.7. The shape of the fifth mode of flexural vibration transversely to the surface of the transducer (Fig. 5)

In this case, the resonance flexural vibrations are excited in the transducer, when the array of the piezoelectric ceramic plates resonates in the third mode (three nodal lines) and the elastic plate resonates in the fourth mode.

The investigation has shown that for frequencies over 80 kHz, multi-component transducers in flexural vibration have to be used. Such transducers can also be with loose or fixed edges. In such transducers, in place of the elastic metal plate, a silicon plate can be used instead. In addition, in place of the piezoelectric ceramic plate, film piezoelectric elements can be used. The working principle of such transducers is the same as of transducers described above, only the design is different.

In Fig. 8, a schematic cross-section of such transducer is presented.

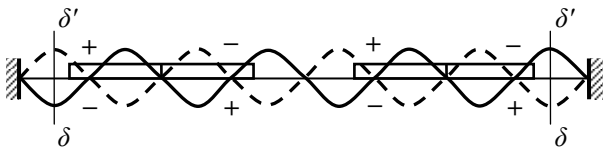

Fig.8. Schematic cross-section of a multi-component piezoelectric transducer

The design of the transducer can be either with fixed edges or with loose edges. In case when the transducer's edges are loose, the cross-dimensions of the transducer are smaller, as shown in Fig. 8 by $\delta'\delta$. It is known that the cross-dimensions of the transducer can be increased by using the resonance frequency forms of elastic plates.

Radiation patterns of rectangular transducers in flexural vibration

As it was mentioned previously, when calculating the radiation patterns of the rectangular transducers in flexural vibration, it is sufficient to calculate these patterns in the plane $z0x$ (Fig. 9), where angle Θ is the angle between the normal to the plane of the transducer and the direction of radiation. In the other perpendicular plane, the radiation pattern of the transducer is calculated in the same way as for an oscillating piston.

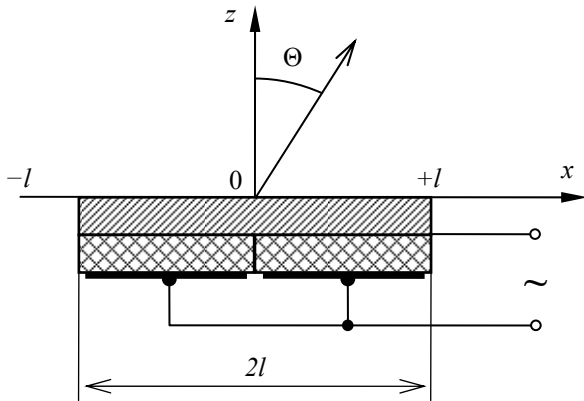

Fig.9. Schematic cross-section for a calculation radiation pattern of an asymmetric bimorph piezoelectric ceramic transducer with loose edges and with parallel electric excitation

The directional radiation pattern of the transducer in the far field in the plane $z0x$ is calculated by using a fact that the pressure created in the far field by the transducer is given by [20]:

$$p = \int_{-l}^l \xi_{mx}(x) \exp\left(-j \frac{2\pi x}{\lambda_0}\right) \sin \Theta dx, \quad (2)$$

where ξ_{mx} is the distribution of the transducer's flexural vibration mode along the x axis; λ_0 – acoustic wavelength in a working environment.

When calculating the radiation pattern of the transducer shown in Fig. 1, the following expression is used [34]:

$$\xi_{mx_l} = A(\cos \alpha - \text{ch } \alpha) \left[\cos\left(\frac{\alpha x}{2l}\right) + \text{ch}\left(\frac{\alpha x}{2l}\right) \right] + (\sin \alpha + \text{sh } \alpha) \left[\sin\left(\frac{\alpha x}{2l}\right) + \text{sh}\left(\frac{\alpha x}{2l}\right) \right], \quad (3)$$

where A is the constant multiplier dependant on the supplied voltage and the parameters of the transducer; $\alpha = kl$, where k is the wave number of the flexural wave:

$$k = \frac{\omega}{c_L} \sqrt[4]{\frac{m \omega^2}{G_{ef}}}, \quad (4)$$

where $\omega = 2\pi f$ is the cyclic frequency; c_L is the velocity of the flexural wave in the transducer; m is the mass of the bimorph transducer; G_{ef} is the effective flexing elasticity:

$$G_{ef} = G - \frac{k_{31}^2}{S_{11}^D} \left(\frac{h_1}{2} - h_0 \right)^2 h_1 l \cdot \frac{2}{\pi}, \quad (5)$$

where the elasticity of flexure G :

$$G = \frac{2}{3\pi} \cdot \frac{1}{S_{11}^D} h_1 (h_1^2 - 3h_1 h_0 + 3h_0^2) + E h_2 (h_2^2 + 3h_2 h_0 + 3h_0^2), \quad (6)$$

where S_{11}^D is the mechanical flexibility of piezoelectric ceramic plate when the electric induction is constant; h_1 and h_2 are the thicknesses of elastic and piezoelectric ceramic plates respectively; h_0 is the thickness of neutral plane of flexural vibration; E is the Young's modulus of the piezoelectric ceramic plate.

When calculating Eq. 2 by using the Eq. 3 and by normalizing the obtained results, we obtain the generalized expression for calculating the radiation pattern of the transducer with loose edges when the count of nodal lines of flexural vibration is odd:

$$D_l(x)_n = \frac{x^2}{n_k^2} \cdot \frac{1 - \left(\frac{n_k}{\alpha_k}\right)^4}{1 + \left(\frac{x}{\alpha_k}\right)^4} \times \left[\frac{\frac{x}{\alpha_k} (\cos \alpha_k - \text{ch } \alpha_k) \cos\left(\frac{x}{2}\right)}{(\sin \alpha_k + \text{sh } \alpha_k) \left[\sin\left(\frac{n_k}{2}\right) + \cos\left(\frac{n_k}{2}\right) \right]} + \frac{(\sin \alpha_k + \text{sh } \alpha_k) \sin\left(\frac{x}{2}\right)}{(\sin \alpha_k + \text{sh } \alpha_k) \left[\sin\left(\frac{n_k}{2}\right) + \cos\left(\frac{n_k}{2}\right) \right]} \right], \quad (7)$$

where $n_k = k_0 \pi$, where k_0 is the number of the nodal lines of flexural vibration on the transducer's surface; α_k is the solutions of equation $\text{cha} \cdot \cos \alpha = 1$;

$$x = \left(\frac{2\pi l}{\lambda_0} \right) \sin \Theta. \quad (8)$$

For cases when $k_0 = 3, 5, 7$, the diagrams for calculating radiation patterns are shown in Fig. 10. These diagrams can be used to calculate real radiation patterns for

various ratios of l/λ_0 . From Eq. 7 we see that by changing the operation frequency of the transducer, the angle Θ can be adjusted.

When calculating the radiation pattern of the transducer shown in Fig. 5 the following expression is used [34]:

$$\xi_{mx_f} = B(\sin \alpha + \text{sh } \alpha) \left[\cos\left(\frac{\alpha x}{l}\right) - \text{ch}\left(\frac{\alpha x}{l}\right) \right] - (\cos \alpha - \text{ch } \alpha) \left[\sin\left(\frac{\alpha x}{l}\right) - \text{sh}\left(\frac{\alpha x}{l}\right) \right] \quad (9)$$

where B is the constant multiplier dependant on the supplied voltage and the parameters of the transducer.

Analogically, we obtain the generalized expression for calculating the radiation pattern of the transducer with fixed edges when the number of nodal lines of flexural vibration is odd:

$$D_f(x)_n = \frac{1 - \left(\frac{n_k}{\alpha_k}\right)^4}{1 - \left(\frac{x}{\alpha_k}\right)^4} \times \left(\frac{\frac{x}{\alpha_k} (\sin \alpha_k - \text{sh } \alpha_k) \cos\left(\frac{x}{2}\right)}{(\text{ch } \alpha_k - \cos \alpha_k) \left[\sin\left(\frac{n_k}{2}\right) + \cos\left(\frac{n_k}{2}\right) \right]} + \frac{(\text{ch } \alpha_k - \cos \alpha_k) \sin\left(\frac{x}{2}\right)}{(\text{ch } \alpha_k - \cos \alpha_k) \left[\sin\left(\frac{n_k}{2}\right) + \cos\left(\frac{n_k}{2}\right) \right]} \right) \quad (10)$$

For cases when $k_0 = 3, 5, 7$, the diagrams for calculating radiation patterns are shown in Fig. 11.

For multi-component transducers (Fig. 8) with sinusoidal distribution of vibration, the expression for calculation of the radiation pattern is:

$$D_s = \frac{1}{l} \int_{-l}^{+l} \sin\left(m_k \frac{2x}{l}\right) e^{-jkx \sin \Theta} dx, \quad (11)$$

where $m_k = k_0(\pi/2)$.

When the Eq. 11 is evaluated, we obtain the expressions to calculate radiation patterns for transducers with loose and fixed edges and with sinusoidal distribution of vibration.

For transducers with loose edges the expression for calculating the radiation pattern is:

$$D_{ls} = \frac{-4x \cos\left(\frac{x}{2}\right) \sin m_k}{x^2 - m_{ls}^2}, \quad (12)$$

where $m_{ls} = k_0\pi$.

For transducers with fixed edges the expression for calculating the radiation pattern is:

$$D_{fs} = \frac{4m_0 \sin\left(\frac{x}{2}\right) \cos m_k}{m_{fs}^2 - x^2}, \quad (13)$$

where $m_{fs} = (k_0 - 1)\pi$.

The normalized Eq. 12 and 13 are shown in Fig. 12 and 13.

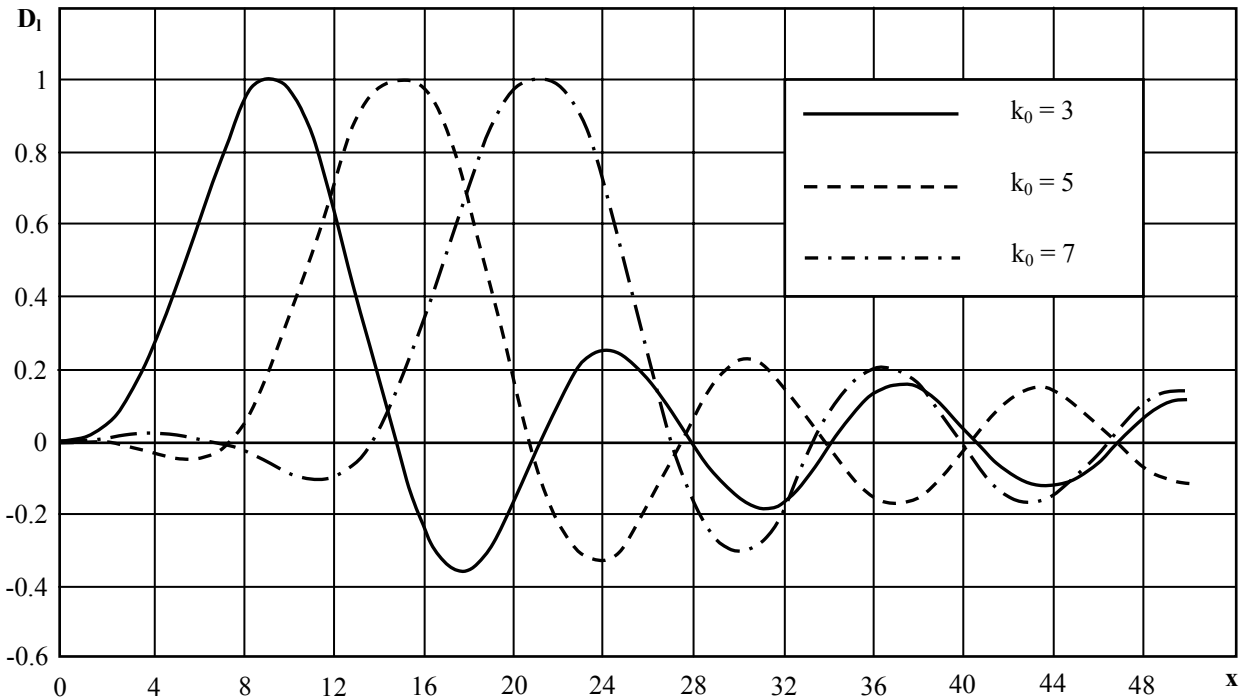

Fig.10. Diagrams for calculation of the radiation patterns for the transducer (Fig. 1) with loose edges

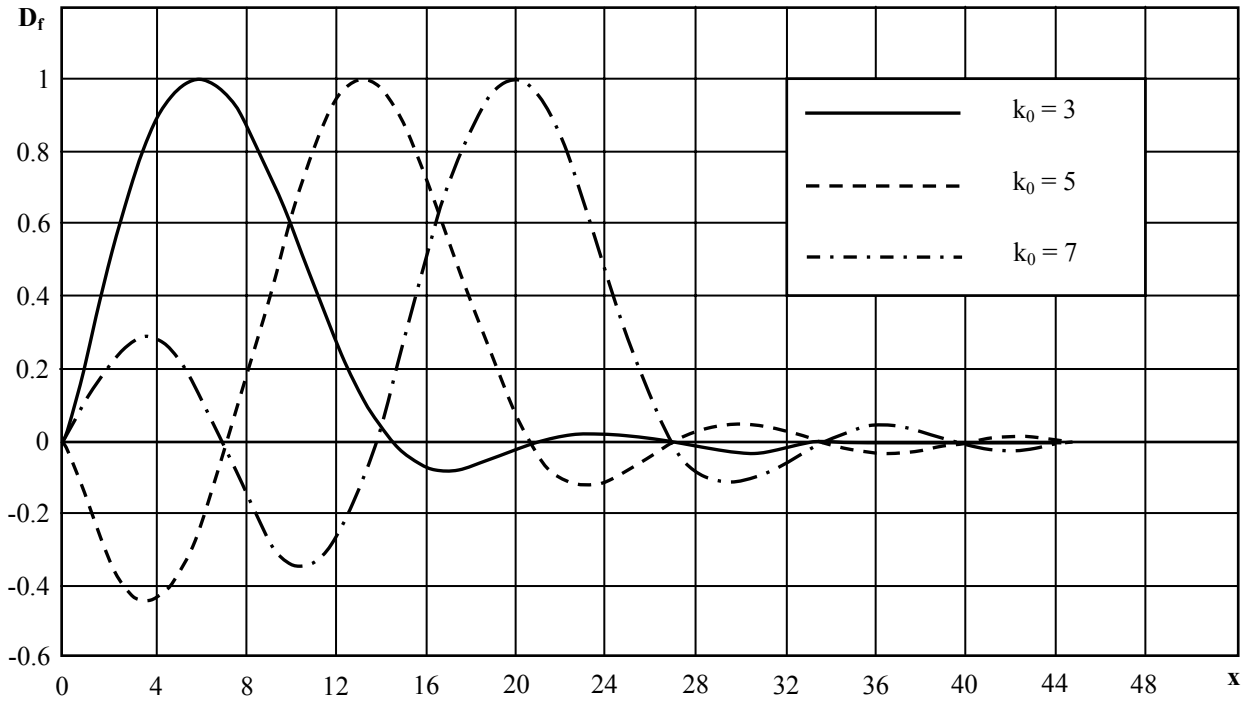

Fig.11. Diagrams for calculation of the radiation patterns for the transducer (Fig. 5) with fixed edges

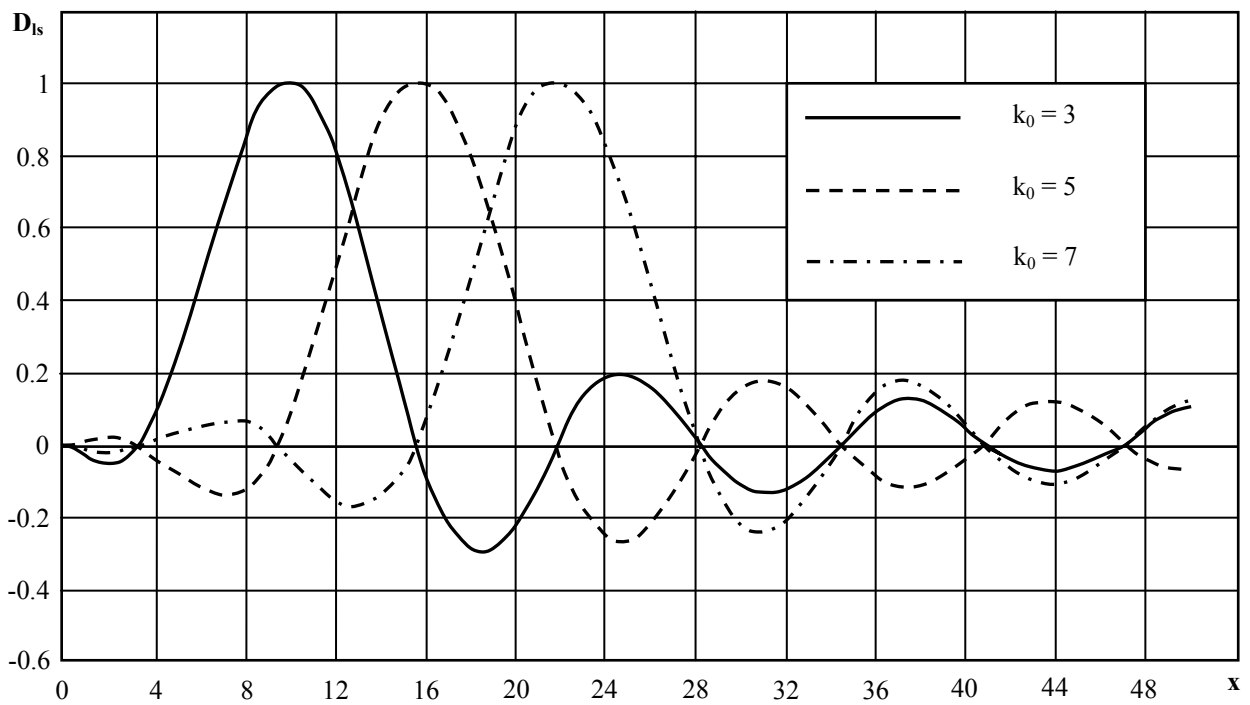

Fig.12. Diagrams for calculation of the radiation patterns for the transducer (Fig. 8) with loose edges and with sinusoidal distribution of vibrations

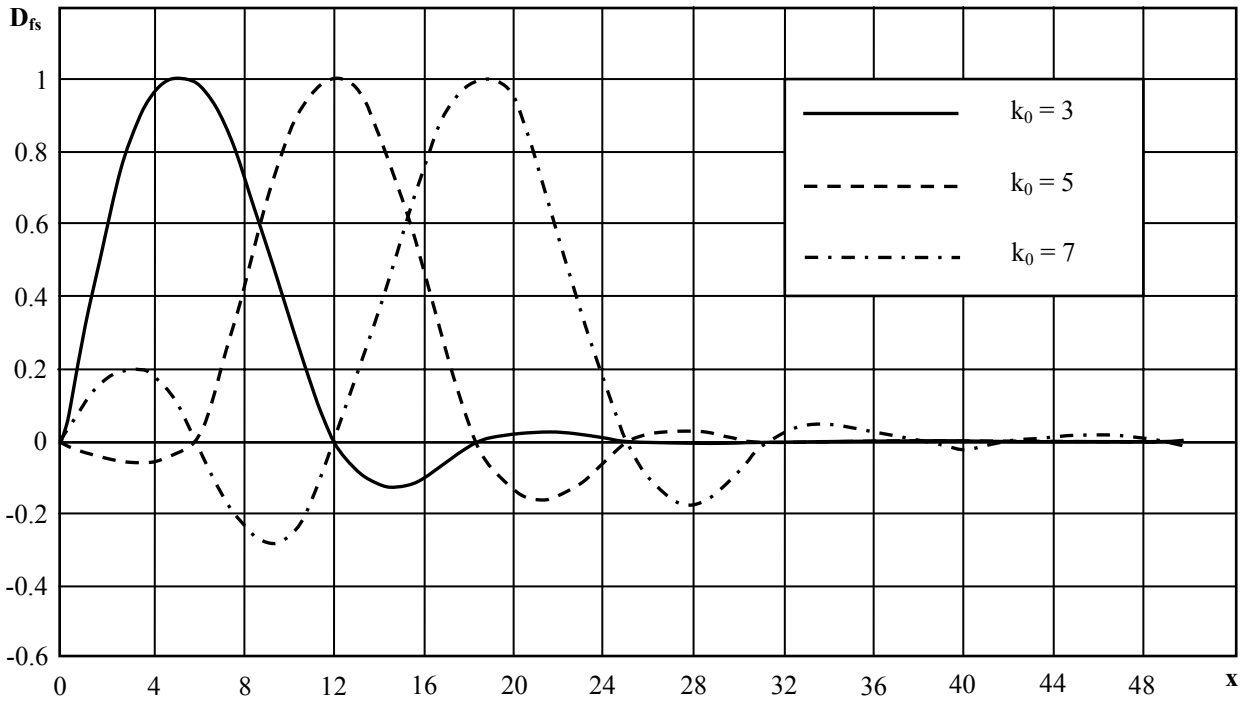

Fig.13. Diagrams for calculation of the radiation patterns for the transducer (Fig. 8) with fixed edges and with sinusoidal distribution of vibrations

In Fig. 14, the dashed line corresponds to the radiation pattern of the transducer with loose edges. This radiation pattern is calculated using Eq. 7. In this case, the width $2l$ of the transducer is 32 mm. The operation frequency of this transducer in air is 35 kHz.

The continuous line in Fig. 14 shows the experimentally measured radiation pattern of the transducer. In this case, the width $2l$ of the transducer is also 32 mm. The transducer consists of two piezoelectric ceramic plates with dimensions 60x16x2 mm. The dimensions of the elastic aluminum plate are 70x32x2 mm.

In Fig. 14 the dotted line corresponds to the radiation pattern with sinusoidal distribution of vibration of the same transducer. This radiation pattern is calculated using expression (12).

From Fig. 14 one can see that the experimental radiation pattern of the piezoelectric ceramic rectangular thin-plate transducer in flexural vibration under free-boundary conditions is in good agreement with the calculated results.

Taking into account the results of the calculation for

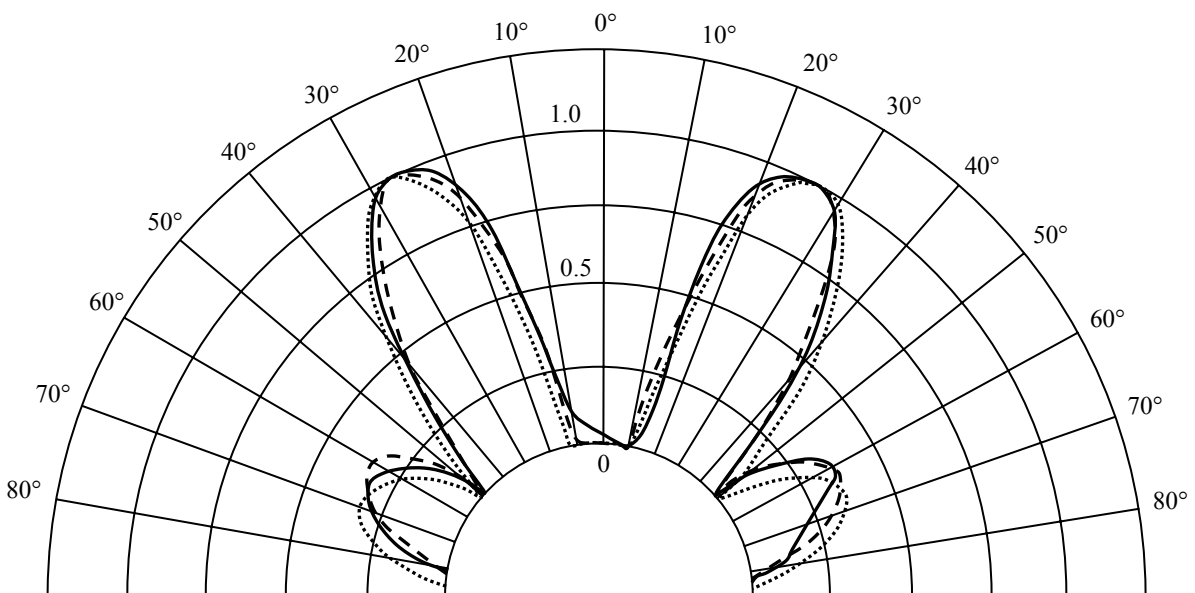

Fig.14. Radiation patterns of the transducer (Fig. 1) with loose edges

the radiation patterns of the transducer with loose edges (Fig. 1), we propose a design of the unidirectional acoustic antenna, consisting of an array of four such transducers. The schematic of such antenna is shown in Fig. 15.

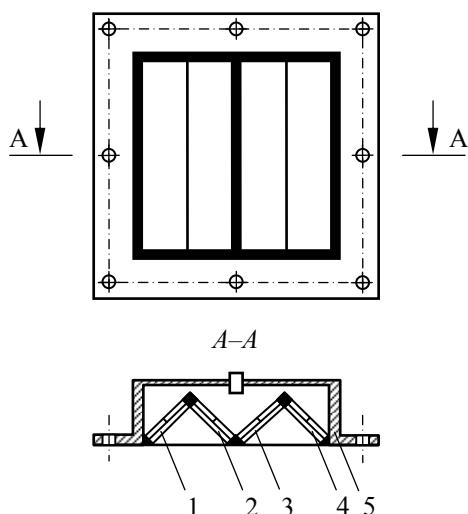

Fig.15. Unidirectional acoustic antenna, consisting of an array of four symmetrical bimorph piezoelectric ceramic transducers (Fig. 1) with loose edges and with parallel electric excitation: 1, 2, 3, 4 – bimorph piezoelectric ceramic transducers; 5 – the encasement of the antenna

The actual image of this antenna is presented in Fig. 16.

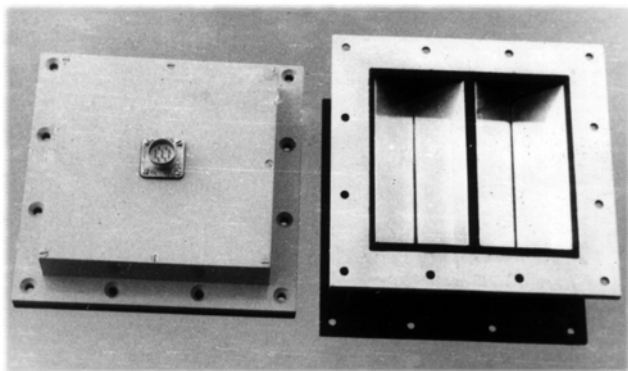

Fig.16. The actual image of the unidirectional acoustic antenna.

Conclusions

Experimental results show that the measured radiation pattern of the transducer in flexural vibration is similar to the calculated radiation pattern.

Transducers in flexural vibration may be used successfully when designing acoustic antennas for various measurements in a gas environment.

The bimorph rectangular transducers with straight and parallel nodal lines of vibrations can successfully be used when designing unidirectional acoustic antennas.

The unidirectional radiation pattern of such antenna can be obtained.

References

1. **Massa F.** Ultrasonic transducers for use in air. Proc. IEEE. 1965. Vol. 53(10). P.1363-1371.
2. **Chen Chao, Tin-Yan Lam, Kin-Wing Kwok and Helen Lai-wa Chan** Piezoelectric micromachined ultrasonic transducers with rectangular diaphragms for dual-frequency applications. Proc. SPIE. 2007. Vol. 6556. 65561J. DOI:10.1117/12.723610.
3. **Baborowski J., Ledermann N., Muralt P., Schmitt D.** Simulation and characterization of piezoelectric micromachined ultrasonic transducers (pMUTs) based on PZT/SOI membranes. Int. J. Comp. Eng. Sci. 2003. Vol. 4. P. 471-475.
4. **Barone A., Gallego-Juarez J. A.** On a modification of vibrating flat plates in order to obtain phase-coherent radiation. Acustica. 1970. Vol. 22. P. 187-188.
5. **Gallego-Juarez J. A., Rodriguez G., San Emeterio J. L., Sanz P. T., Lazaro J. C.** An acoustic transducer system for long-distance ranging applications in air. Sensors and actuators: A. physical. 1993. Vol.37-38(C). P. 397-402.
6. **Gallego-Juarez J. A.** Piezoelectric ceramics and ultrasonic transducers. Journal of Physics E: Scientific Instruments 1689. Vol. 22 (10). Art. No. 001. P. 804-816.
7. **Lin S.** Study on the high power air-coupled ultrasonic compound transducer. Ultrasonics. 2006. Vol.44 (SUPPL.). P. e545-e548.
8. **Lin S.** Piezoelectric ceramic rectangular transducers in flexural vibration. IEEE Transactions on ultrasonics, ferroelectrics and frequency control. 2004. Vol. 51. No.7. P. 865-870.
9. **Lin S.** Study on the Langevin piezoelectric ceramic ultrasonic transducer of longitudinal-flexural composite vibrational mode. Yadian Yu Shengguang /Piezoelectrics and acoustooptics. 2005. Vol.27. No.6. P. 620-623.
10. **Shu-Yu L.** High power air-borne ultrasonic transducers. Acta physica Sinica (overseas Edition). 1999. 8 SUPPL. No.1. P. S38-S41.
11. **Danilov V. N., Ermolov I. N.** Estimation of the length of the near zone of a rectangular transducer. Russian Journal of nondestructive testing. 2003. Vol.39. No.5. P. 333-338.
12. **Xian X., Lin S.** Study on the compound multifrequency ultrasonic transducer in flexural vibration. Ultrasonics. 2008. Vol. 48. No.3. P.202-208.
13. **Shuyu L.** Study on the radiation acoustic field of rectangular radiators in flexural vibration. Journal of sound and vibration. 2002. Vol.254. No.3. P. 469-479. doi:10.1006/jsvi. 2001.4095.
14. **Shuyu L.** Study on the flexural vibration of rectangular thin plates with free boundary conditions. Journal of sound and vibration. 2001. Vol.239. No. 5. P. 1063-1071.
15. **Shuyu L** Equivalent circuits and directivity patterns of air-coupled ultrasonic transducers. Journal of the acoustical society of America. 2001. Vol.109. No. 3. P. 949-957.
16. **Farag N. H., Pan J.** Free and forced in-plane vibration of rectangular plates. Journal of the acoustical society of America. 1998. Vol.103. No.1. P. 408-413.
17. **Sung C.-C., Jan J. T.** The response of and sound power radiated by a clamped rectangular plate. Journal of sound and vibration. 1997. Vol.207. No.3. P. 301-317.
18. **Li N.** Forced vibration analysis of the clamped orthotropic rectangular plate by the superposition method. Journal of sound and vibration. 1992. Vol.158. No.2. P. 307-316.
19. **Warbuton G. B.** The vibration of rectangular plates. Proceedings of Institute of mechanical engineers. 1954. Vol.168. P. 371-381.
20. **Rayleigh L.** Theory of sound.(two volumes). New York: Dover Publications; 1987second edition. 1945 re-issue.
21. **Szilard R.** Theory and analysis of plates. Classical and numerical methods. New Jersey: Prentice-Hall.1966. P. 435.
22. **Jiang H., Adams D. E., Jata K.** Material damage modeling and detection in a homogeneous thin metallic sheet and sandwich panel using passive acoustic transmission. Structural Health Monitoring. December 2006. Vol. 5, Issue 4. P. 373-387. doi:10.1177/1475921706067764.

23. **Ruzzene M.** Vibration and sound radiation of sandwich beams with honeycomb truss core. *Journal of sound and vibration*. 2004. Vol.277. No.4-5. P. 741-763. doi: 10.1016/j.jsv.2003.09.026.
24. **Sorokin S. V.** Vibrations of and sound radiation from sandwich plates in heavy fluid loading conditions. *Composite structures*. 2000. Vol.48. No.4. P.219-230. doi:10.1016/S0263-8223(99)00103-8.
25. **Babic M.** A 200-kHz ultrasonic transducer coupled to the air with a radiating membrane. *Ultrasonics, ferroelectrics and frequency control*. IEEE Transactions. 1991. Vol.38. P.252 – 255.
26. **Brissaud M.** Theoretical modelling of non-symmetric circular piezoelectric bimorphs. *Journal of micromechanics and microengineering*. 2006. Nr. 16. P.875-885.
27. **Yamane H., Kawamura M.** Sound sources with vibration plates in flexural modes and reflection plates for airborne ultrasonics. *J. Acoust. Soc. Japan*. 1976. Vol. 32. No.2. P.83-91.
28. **Bindal V. and Chandra M.** An improved piezoelectric ceramic transducer for ultrasonic applications in air. *Archives of acoustics*. 1982. Vol. 7. No.3-4. P. 281-286.
29. **Honda Y., Matsuhisa H. and Sato S.** Radiation efficiency of a baffled circular plate in flexural vibration. *Journal of sound and vibration*. 1983. Vol.88. No. 4. P. 437-446.
30. **Barone A., Gallego-Juarez J A.** Flexural vibrating free-edge plates with stepped thickness for generating high directional ultrasonic radiation. *JASA*. 1972. Vol.51. No.3. P.953-959.
31. **Germano C. P.** Flexure mode piezoelectric transducers. *IEEE Transactions on audio and electroacoustics*. 1971. Vol. AU-19. No.1. P.6-12.
32. **Matsuzava K.** Sound sources for producing intense ultrasonic fields in small regions in air. – In: Eighth International Congress on Acoustics. London. 1974. Vol.11. P.709.
33. **Петраускас А., Домаркас В.** Особенности работы прямоугольных биморфных электроакустических преобразователей со свободными краями (in Russian). Вильнюс: Минтис. Ультразвук (Ultrasound). 1974. No.6. P.103-108.
34. **Petrauskas A.** Investigation and construction of measuring transducers for ultrasonic devices using flexural vibrations. Ph. D. thesis. Kaunas. 1975. P.147. (in Russian).
35. **Домаркас В., Мажонас А., Петраускас А.** Изгибные колебания составных прямоугольных пьезопреобразователей. ISSN 0369-6367 (in Russian). Вильнюс: Минтис. Ультразвук (Ultrasound). 1989. Nr.21. P.43-50.
36. **Домаркас В., Петраускас А.** Колебания асимметричных биморфных пьезоизлучателей (in Russian). Вильнюс: Минтис. Ультразвук (Ultrasound). 1976. No.8. P.57-64.
37. **Домаркас В., Петраускас А.** Биморфные пьезокерамические преобразователи для измерений в газовых средах (in Russian). Вильнюс: Минтис. Ультразвук (Ultrasound). 1978. No.10. P.55-64.
38. **Домаркас В.** Эквивалентные четырехполюсники асимметричных биморфных пьезоэлектрических преобразователей. ISSN 0369-6367 (in Russian). Вильнюс: Минтис. Ультразвук (Ultrasound). 1984. No.16. P.20-30.
39. **Теумин Н. И.** Ультразвуковые колебательные системы (in Russian). Moscow: Машгиз. 1959. 332 с.
40. **Бабиков И. П.** Теория колебаний (in Russian). Moscow: Госиздат технико-теоретич. литературы. 1958. P. 627.
41. **Kikuchi E.** Ultrasonic transducers (in Russian). Moscow: Mir. 1972. P.424.
42. **Домаркас В., Мажонас А., Петраускас А.** Исследование характеристик направленности пьезопреобразователей изгибных колебаний. ISSN 636-6367 (in Russian). Вильнюс: Минтис. Ультразвук (Ultrasound). 1983. No.15. P.48-51.
43. **Мажонас А., Петраускас А.** Оптимизация характеристик направленности акустических антенн. ISSN 0369-6367 (in Russian). Вильнюс: Минтис. Ультразвук (Ultrasound). 1984. No.16. P. 84-87.
44. **Miniąla V., Petrauskas A.** Estimation of directivity patterns of two rectangular acoustic radiators oriented at various angles. ISSN 1392 – 2114 Ultragarsas (Ultrasound). Kaunas: Technologija. 1998. No1(29). P. 20-23.
45. **Домаркас В., Петраускас А., Мажонас А.** Многоэлементные пьезокерамические преобразователи изгибных колебаний. ISSN 636-6367 (in Russian). Вильнюс: Минтис. Ультразвук (Ultrasound). 1981. No.13. P.24 - 29.
46. **Petrauskas A.** The optimization of directional characteristics for acoustic antennas from piezoceramic rectangular bimorph transducers in flexural vibration.. ISSN 1392 – 2114 Ultragarsas (Ultrasound). Kaunas: Technologija. 2007. No 1(62). P. 26-32.

A. Petrauskas

Apie stačiakampių bиморфinių akustinių keitiklių su pьзоелектринėmis keraminėmis plokštelėmis konstrukcijas ir spinduliavimo charakteristikas

Reziumė

Aprašomos stačiakampių bиморфinių pьзokeraminių keitiklių su laisvais ir įtvirtintais kraštais konstrukcijos ir, remiantis klasikine teorija, nagrinėjamos jų spinduliavimo charakteristikos. Pateiktos diagramos tokių keitiklių spinduliavimo kryptinėms charakteristikoms apskaičiuoti. Pažymima, kad efektyviam tokių keitiklių darbui reikia suderinti pьзokeraminių paketų virpesius su elastinių plokštelių, prie kurių šie paketai pritvirtinti, virpesiais. Pabrėžiama, jog, apskaičiuojant paprastų keitiklių kryptines charakteristikas, svarbu įvertinti jų virpesių formos išraiškas. Apskaičiuojant daugiaelementų lankstymosi virpesių keitiklių spinduliavimo charakteristikas, galima laikyti jų virpesių pasiskirstymą ant keitiklio paviršiaus harmoniniu. Pažymėta, jog bиморфinių keitiklių spinduliavimo kampas priklauso nuo akustinių bangų ilgio santykio keitiklio paviršiuje ir darbo aplinkoje. Nedidelis keitiklio spinduliavimo kampo pokytis gali priklausyti ir nuo darbo dažnio. Pateikiama konkreti vienkryptės akustinės antenos konstrukcija, sudaryta iš stačiakampių bиморфinių keitiklių gardelės.

Pateikta spaudai 2008 11 28

DOI: 10.5755/j01.u.63.4.17088