

Design and the radiation patterns of rectangular symmetric bimorph piezoelectric transducers in cosinusoidal flexural vibration

A. Petrauskas

Prof. K. Baršauskas Ultrasound Institute

Kaunas University of Technology

Studentų st. 50, LT-51368 Kaunas, Lithuania

E-mail: Algimantas.Petrauskas@ktu.lt

Abstract

In this article, the design of rectangular symmetric bimorph piezoelectric ceramic transducers with loose and fixed edges and with parallel electric excitation is studied. Rectangular piezoelectric ceramic transducers in cosinusoidal flexural vibration with straight and parallel nodal lines of vibration are studied. The radiation of the transducer in a plane perpendicular to the surface of the transducer and parallel to the nodal lines of vibrations is examined. The radiation patterns of such transducers are evaluated using the classic theory. The radiation pattern of the transducer is evaluated in a plane, perpendicular to the direction of flexural vibration of the nodal lines. In another perpendicular plane, the radiation pattern of the transducer is calculated the same as for an oscillating piston. Diagrams to calculate these radiation patterns are supplied. For effective operation of such transducers, vibrations of the piezoelectric ceramic plate arrays with the vibrations of elastic plates, on which the arrays are mounted, must be matched. When calculating the radiation patterns of simple bimorph rectangular transducers, the expressions of the transducer's flexural vibration mode must be evaluated. In case of multi-component rectangular transducers, the distribution of vibrations on the transducer's surface can be evaluated as harmonic. To aid the design of a transducer with one piezoelectric ceramic plate, a diagram for calculating the width of the ceramic plate and the width of the elastic metal plate is presented.

Keywords: piezoelectric ceramic transducer, piezoelectric ceramic plate, radiation pattern, flexural vibration, cosinusoidal flexural vibration, parallel nodal lines of flexural vibration, design of piezoelectric transducers

Introduction

At present time, piezoelectric ceramic transducers in longitudinal vibration with matching layers and transducers in flexural vibration are both used in a gas environment [1-31]. The usage of transducers in a flexural mode gives the best possibility to match acoustic impedances of air and the transducer, because flexural transducers have a sufficiently low acoustic impedance. Because of this, these transducers have an advantage over the transducers in longitudinal vibration with matching layers.

Piezoelectric ceramic transducers in flexural vibration have a solid radiating surface and therefore are resistant to the effects of the aggressive gas environment. The application of these transducers in gas environments is currently being widely investigated.

When designing transducers in flexural vibration, the piezoelectric ceramic rectangular thin-plate transducer in cosinusoidal flexural vibration can also be used [1, 32-45]. As will be mentioned below, the required radiation patterns of these rectangular transducers can be easily obtained.

The relatively easily manageable radiation patterns can be obtained when nodal lines of vibrations on the surface of the rectangular bimorph transducer are straight and parallel to one another [1, 32-34]. The radiation of these transducers in a plane perpendicular to the surface of the transducer and parallel to the nodal lines of vibrations is the same as an acoustic field generated by an oscillating piston. In a perpendicular plane, if flexural transducer is flat, the transducer reveals a primary two-leaf radiation pattern and the inclination angle α between the surface of the transducer and a plane, perpendicular to the direction

of radiation [1]. This angle depends on a ratio of acoustic wavelength in transducer and in air.

Various authors propose a variety of designs for such transducers [1, 2, 5-10, 27, 28, 32, 34, 37, 41, 45, 46].

Designs of transducers in flexural vibration

In our opinion, it is convenient in practice to use transducers when flexural vibrations are excited in them by transversal or longitudinal displacement. It is preferred that these displacements should be distributed on the entire surface of the transducer. When exciting flexural vibrations in this way, the piezoelectric ceramic transducer has a high efficiency, comparatively small dimensions and a low weight.

The design of such transducer [34] is presented in Fig. 1. The piezoelectric transducer consists of one elastic plate and one rectangular piezoelectric ceramic plate, on which the piezoelectric ceramic plate is solidly mounted. When electric pulses are supplied to the electrodes attached to the piezoelectric ceramic plate, flexural vibrations are being excited in the unit of ceramic and elastic plates. The elastic plate radiates into a gas environment. Such transducer vibrates in flexural and longitudinal modes. In the low end of the frequencies, flexural resonance frequencies can be excited in the transducer. Parallel nodal lines of the flexural vibrations are present both lengthwise and breadthwise on the surface of the transducer.

In Fig. 2, the shape of the second mode of flexural vibration, transverse to the surface of the transducer presented in Fig. 1, is shown.

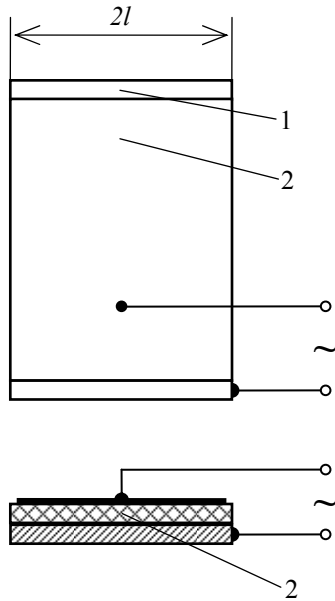

Fig. 1. Symmetric bimorph piezoelectric ceramic transducer (width $2l$) with loose edges: 1 – thin rectangular elastic (metal) plate; 2 – piezoelectric ceramic plate with electrodes

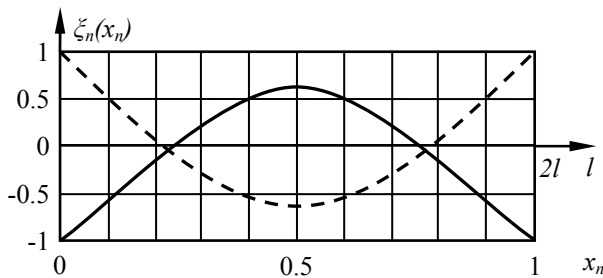

Fig. 2. The shape of the second mode of flexural vibration transversely to the surface of the transducer (Fig. 1) (normalized value)

After choosing special dimensions for piezoelectric ceramic and elastic plates, the resonance flexural vibration can be excited in the elastic plate, fixed on a rectangular frame along the whole perimeter. The design of such transducer is given in Fig. 3.

The piezoelectric ceramic transducer (Fig. 3) consists of one rectangular piezoelectric ceramic plate with a normal polarization. The plate is mounted on a thin rectangular elastic plate, which is fixed on a rectangular frame along the whole perimeter. When electric pulses are supplied to the electrodes of the piezoelectric ceramic plate, cosinusoidal flexural vibrations are being excited in the ceramic plate. Nodal lines of flexural vibration are always present transversely and along the surface of the piezoelectric ceramic plate. It can be seen in practice when observing Chladni figures on the transducer's surface (Fig. 4 and Fig. 5).

As seen from Fig. 4, the piezoelectric ceramic transducer has a resonance frequency at the fifth mode (Fig. 4a) of flexural vibration along the surface of the transducer at the frequency of 10.23 kHz and a resonance frequency of the third mode (Fig. 4b) of flexural vibration transversely to the surface of the transducer at the frequency of 27.17 kHz.

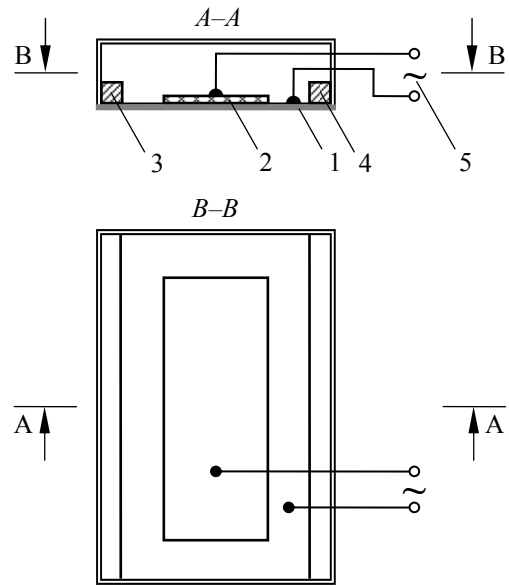

Fig. 3. Symmetric bimorph piezoelectric ceramic transducer with fixed edges: 1 – rectangular elastic plate; 2 – piezoelectric ceramic plate; 3, 4 – rectangular frame; 5 – electric excitation

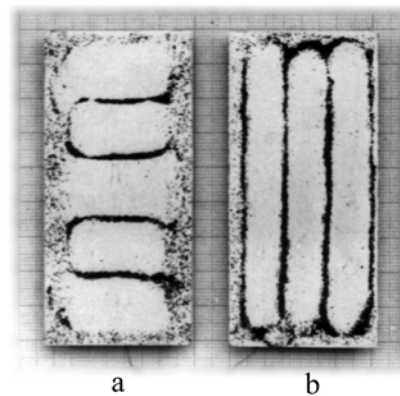

Fig. 4. Chladni figures on the surface of the transducer (Fig. 3), consisting of an aluminum plate (measuring 81.0x43.3x1.0 mm) and a piezoelectric ceramic plate (measuring 60.0x15.0x1.5 mm): a – frequency is 10.23 kHz; b – frequency is 27.17 kHz

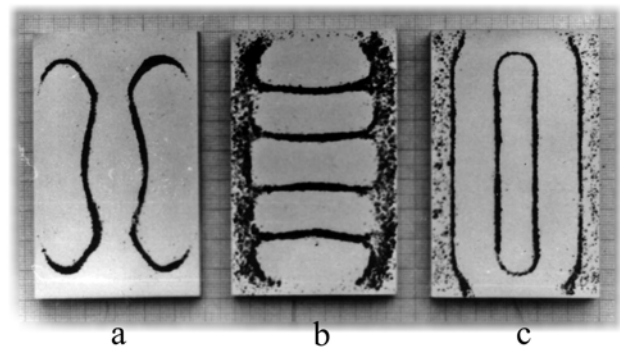

Fig. 5. Chladni figures on the surface of the transducer (Fig. 3), consisting of an aluminum plate (measuring 81.0x44.0x1.0 mm) and a piezoelectric ceramic plate (measuring 60.0x20.0x1.0 mm): a – frequency is 7.09 kHz; b – frequency is 16.89 kHz; c – frequency is 19.03 kHz

From Fig. 4a one can see that transversely to the surface of the transducer flexural vibrations have the same phase. From Fig. 4b one can see that along the transducer's

surface flexural vibrations also have the same phase. Because of that, such transducer has a two-leaf radiation pattern. These vibrations of the transducer could be used when designing acoustic antennas with two-leaf or one-leaf radiation patterns of different widths. These antennas can be used for various measurements in a gas environment.

In practical applications we noticed that the third mode of cosinusoidal flexural vibration is the most interesting (Fig. 6).

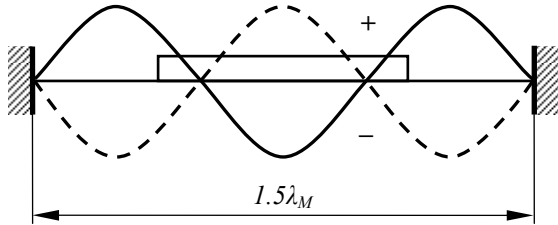

Fig. 6. The shape of the third mode of flexural vibration transversely to the surface of the transducer (Fig. 3)

In this case, the resonance flexural vibrations are excited in the transducer, when the piezoelectric ceramic plate resonates in the second mode (two nodal lines) and the elastic plate resonates in the third mode (four nodal lines).

The investigation has shown that for frequencies over 80 kHz, multi-component transducers in flexural vibration have to be used. Such transducers can also be with loose or fixed edges. In such transducers, in place of the elastic metal plate, a silicon plate can be used instead. In addition, in place of the piezoelectric ceramic plate, film piezoelectric elements can be used. The working principle of such transducers is the same as of transducers described above. Only the design is different.

In Fig. 8, a schematic cross-section of a transducer, with an elastic plate, fixed on a rectangular frame along the whole perimeter is presented. In case when the transducer has loose edges, the width of the multi-component transducer have to be decreased as shown in Fig. 7 by $\alpha\alpha'$. For effective operation of such transducers, vibrations of the piezoelectric ceramic plate arrays with the vibrations of elastic plates, on which the arrays are mounted, must be matched. In the design of the multi-component transducer, presented in Fig. 7, three rectangular piezoelectric ceramic plates vibrate in the second mode of cosinusoidal flexural vibration and the elastic plate vibrates in the seventh mode of cosinusoidal flexural vibration.

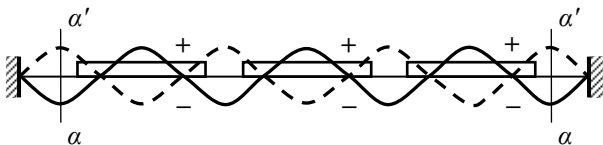

Fig. 7. Schematic cross-section of a multi-component piezoelectric transducer

It needs to be noted that the cosinusoidal distribution of vibrations can be obtained by using asymmetric piezoelectric ceramic arrays of opposite polarization (Fig. 8) [1].

The design of the transducer can also be either with fixed edges or with loose edges [1]. In case when the

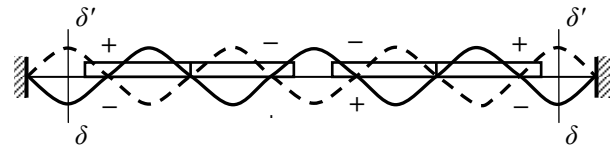

Fig. 8. Schematic cross-section of a multi-component piezoelectric transducer with asymmetric piezoelectric ceramic arrays of opposite polarization

transducer's edges are loose, the cross-dimensions of the transducer are smaller, as shown in Fig. 8 by $\delta'\delta$. It is known that the lateral-dimensions of the transducer can be increased by using the resonance frequency forms of elastic plates. For effective operation of such transducers, vibrations of the piezoelectric ceramic plate arrays with the vibrations of elastic plates, on which the arrays are mounted, must be matched. In the design of the multi-component transducer, presented in Fig. 8, two units of asymmetric rectangular piezoelectric ceramic arrays vibrate in the third mode of sinusoidal flexural vibration and the elastic plate vibrates in the seventh mode of cosinusoidal flexural vibration.

Radiation patterns of rectangular transducers in cosinusoidal flexural vibration

As was mentioned previously [1], when calculating the radiation patterns of rectangular flexural transducers, it is sufficient to calculate these patterns in the plane zOx (Fig. 9), where angle Θ is the angle between the normal to the plane of the transducer and the direction of radiation. In an other perpendicular plane, the radiation pattern of the transducer is calculated in the same way as for an oscillating piston.

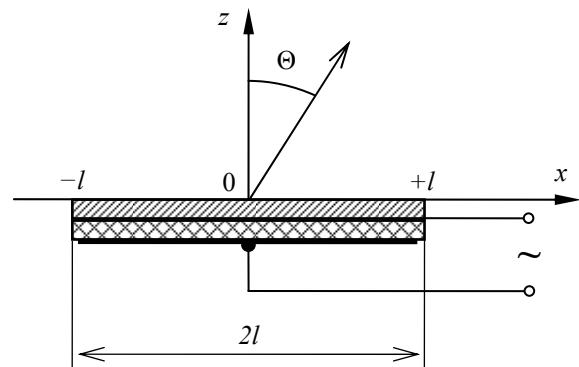

Fig. 9. Schematic cross-section for calculation of the radiation pattern of a symmetric bimorph piezoelectric ceramic transducer with loose edges

The directional radiation pattern of the transducer in the far field in the plane zOx is calculated by using the fact that the pressure created in the far field by the transducer is given by [20]:

$$p = \int_{-l}^l \xi_{mx}(x) \exp\left(-j \frac{2\pi x}{\lambda_0}\right) \sin \Theta dx, \quad (1)$$

where ξ_{mx} is the distribution of the transducer's flexural vibration mode along the x axis; λ_0 – acoustic wavelength in a working environment.

When calculating the radiation pattern of the transducer shown in Fig. 1, the following expression is used [34]:

$$\xi_{mx_l} = A(\cos \alpha - \text{ch} \alpha) \left[\cos \left(\frac{\alpha x}{2l} \right) + \text{ch} \left(\frac{\alpha x}{2l} \right) \right] + (\sin \alpha + \text{sh} \alpha) \left[\sin \left(\frac{\alpha x}{2l} \right) + \text{sh} \left(\frac{\alpha x}{2l} \right) \right], \quad (2)$$

where A is the constant multiplier dependant on the supplied voltage and the parameters of the transducer; $\alpha = kl$, where k is the wave number of the flexural wave:

$$k = \frac{\omega}{c_L} \sqrt{\frac{m\omega^2}{G_{ef}}}, \quad (3)$$

where $\omega = 2\pi f$ is the cyclic frequency; c_L is the velocity of the flexural wave in the transducer; m is the mass of the bimorph transducer; G_{ef} is the effective flexing elasticity:

$$G_{ef} = G - \frac{k_{31}^2}{S_{11}^D} \left(\frac{h_1}{2} - h_0 \right)^2 h_1 l \cdot \frac{2}{\pi}, \quad (4)$$

where the elasticity of flexure G is given by

$$G = \frac{2}{3\pi} \cdot \frac{1}{S_{11}^D} h_1 (h_1^2 - 3h_1 h_0 + 3h_0^2) + E h_2 (h_2^2 + 3h_2 h_0 + 3h_0^2), \quad (5)$$

where S_{11}^D is the mechanical flexibility of the piezoelectric ceramic plate when the electric induction is constant; h_1 and h_2 are the thicknesses of elastic and piezoelectric ceramic plates respectively; h_0 is the thickness of neutral plane of flexural vibration; E is the Young's modulus of the piezoelectric ceramic plate.

When calculating Eq. 1 by using Eq. 2 and by normalizing the obtained results, we obtain the expression for calculation of the radiation pattern of the transducer with loose edges when the number of nodal lines of flexural vibration is even:

$$D_l(x)_n = \frac{x^2}{n_k^2} \cdot \frac{1 - \left(\frac{n_k}{\alpha_k} \right)^4}{1 + \left(\frac{x}{\alpha_k} \right)^4} \times \left(\frac{(\sin \alpha_k + \text{sh} \alpha_k) \cos \left(\frac{x}{2} \right)}{(\sin \alpha_k + \text{sh} \alpha_k) \left[\sin \left(\frac{n_k}{2} \right) + \cos \left(\frac{n_k}{2} \right) \right]} - \frac{\frac{x}{\alpha_k} (\cos \alpha_k - \text{ch} \alpha_k) \sin \left(\frac{x}{2} \right)}{(\sin \alpha_k + \text{sh} \alpha_k) \left[\sin \left(\frac{n_k}{2} \right) + \cos \left(\frac{n_k}{2} \right) \right]} \right), \quad (6)$$

where $n_k = k_0 \pi$, where k_0 is the number of the nodal lines of flexural vibration on the transducer's surface; α_k is the solutions of equation $\text{ch} a \cdot \cos \alpha = 1$;

$$x = \left(\frac{2\pi l}{\lambda_0} \right) \sin \Theta. \quad (7)$$

For cases when $k_0 = 2, 4, 6$, the diagrams for calculation of the radiation patterns are shown in Fig. 10.

These diagrams can be used to calculate real radiation patterns for various ratios of l/λ_0 . In addition, from Eq. 7 we see that by changing the operating frequency of the transducer, the angle Θ can be adjusted.

When calculating the radiation pattern of the transducer shown in Fig. 3 the following expression is used [34]:

$$\xi_{mx_f} = B(\sin \alpha + \text{sh} \alpha) \left[\cos \left(\frac{\alpha x}{l} \right) - \text{ch} \left(\frac{\alpha x}{l} \right) \right] - (\cos \alpha - \text{ch} \alpha) \left[\sin \left(\frac{\alpha x}{l} \right) - \text{sh} \left(\frac{\alpha x}{l} \right) \right], \quad (8)$$

where B is the constant multiplier dependant on the supplied voltage and the parameters of the transducer.

Analogically [1], we obtain the expression for calculation of the radiation pattern of the transducer with fixed edges when the number of nodal lines of flexural vibration is even:

$$D_f(x)_n = \frac{1 - \left(\frac{n_k}{\alpha_k} \right)^4}{1 - \left(\frac{x}{\alpha_k} \right)^4} \times \left(\frac{(\text{ch} \alpha_k - \cos \alpha_k) \cos \left(\frac{x}{2} \right)}{(\text{ch} \alpha_k - \cos \alpha_k) \left[\sin \left(\frac{n_k}{2} \right) + \cos \left(\frac{n_k}{2} \right) \right]} - \frac{\frac{x}{\alpha_k} (\sin \alpha_k - \text{sh} \alpha_k) \sin \left(\frac{x}{2} \right)}{(\text{ch} \alpha_k - \cos \alpha_k) \left[\sin \left(\frac{n_k}{2} \right) + \cos \left(\frac{n_k}{2} \right) \right]} \right). \quad (9)$$

For cases when $k_0 = 2, 4, 6$, the diagrams for calculation of the radiation patterns are shown in Fig. 11.

For multi-component transducers (Fig. 7 and 8) with cosinusoidal distribution of vibrations, the expression for calculation of the radiation pattern is:

$$D_c = \frac{1}{l} \int_{-l}^{+l} \cos \left(m_k \frac{2x}{l} \right) e^{-jkx \sin \Theta} dx, \quad (10)$$

where $m_k = k_0(\pi/2)$ – for the transducers with loose edges and $m_k = (k_0 - 1)(\pi/2)$ – for the transducers with fixed edges.

When Eq. 10 is evaluated, we obtain the expressions for calculation of radiation patterns for transducers with loose and fixed edges and with the cosinusoidal distribution of vibrations.

For transducers with loose edges the expression for calculation of the radiation pattern is:

$$D_{lc} = \frac{2x \sin \left(\frac{x}{2} \right) \cos m_k}{m_0^2 - x^2}, \quad (11)$$

where $m_0 = (k_0 - 1)\pi$.

For transducers with fixed edges the expression for calculation of the radiation pattern is:

$$D_{fc} = \frac{2m_0 \cos\left(\frac{x}{2}\right) \sin m_k}{m_0^2 - x^2}, \quad (12)$$

The normalized Eq. 11 and Eq. 12 are shown in Fig. 12 and 13.

where $m_0 = k_0\pi$.

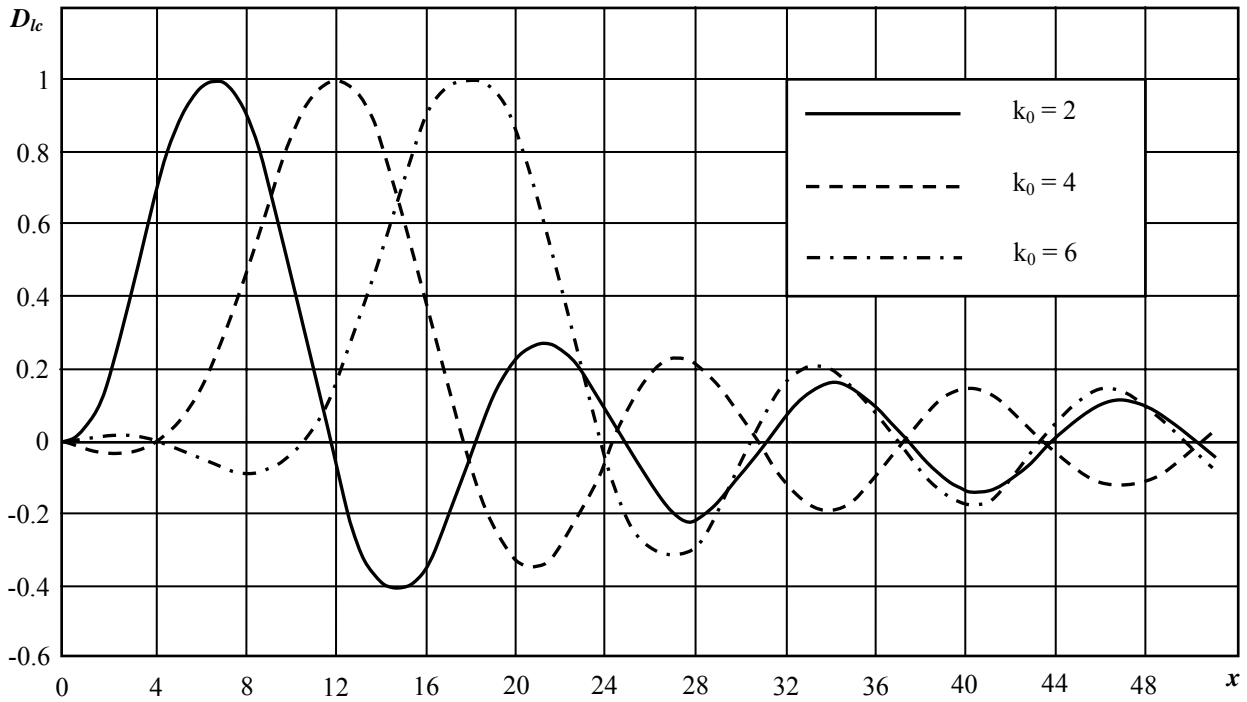

Fig.10. Diagrams for calculation of the radiation patterns for the transducer (Fig. 1) with loose edges

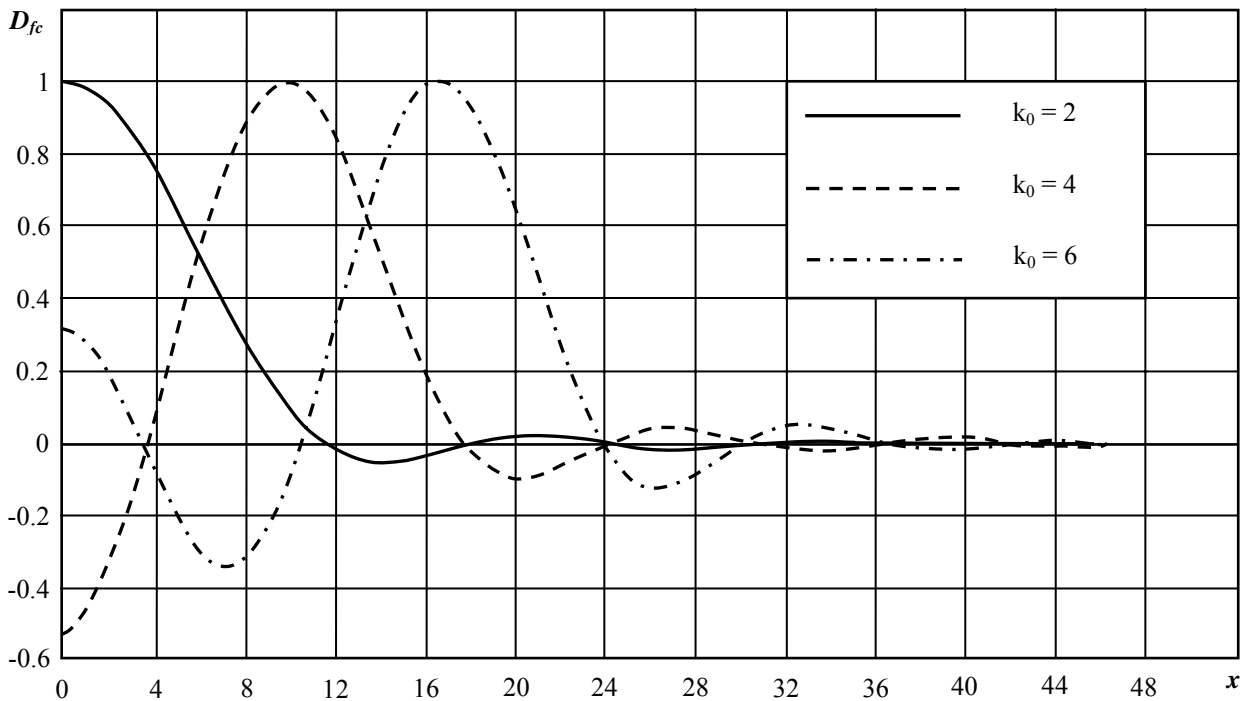

Fig.11. Diagrams for calculation of the radiation patterns for the transducer (Fig. 3) with fixed edges

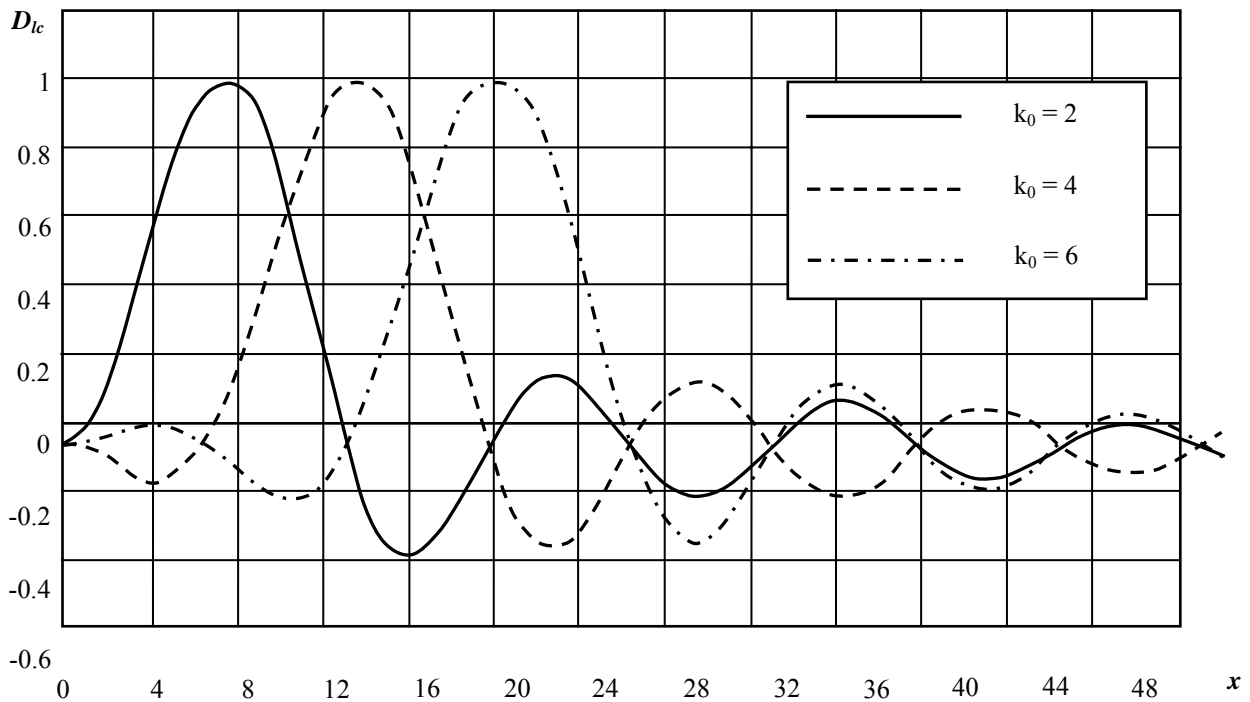

Fig.12. Diagrams for calculation of the radiation patterns for the transducers (Fig. 7 and Fig. 8) with loose edges and with cosinusoidal distribution of vibrations

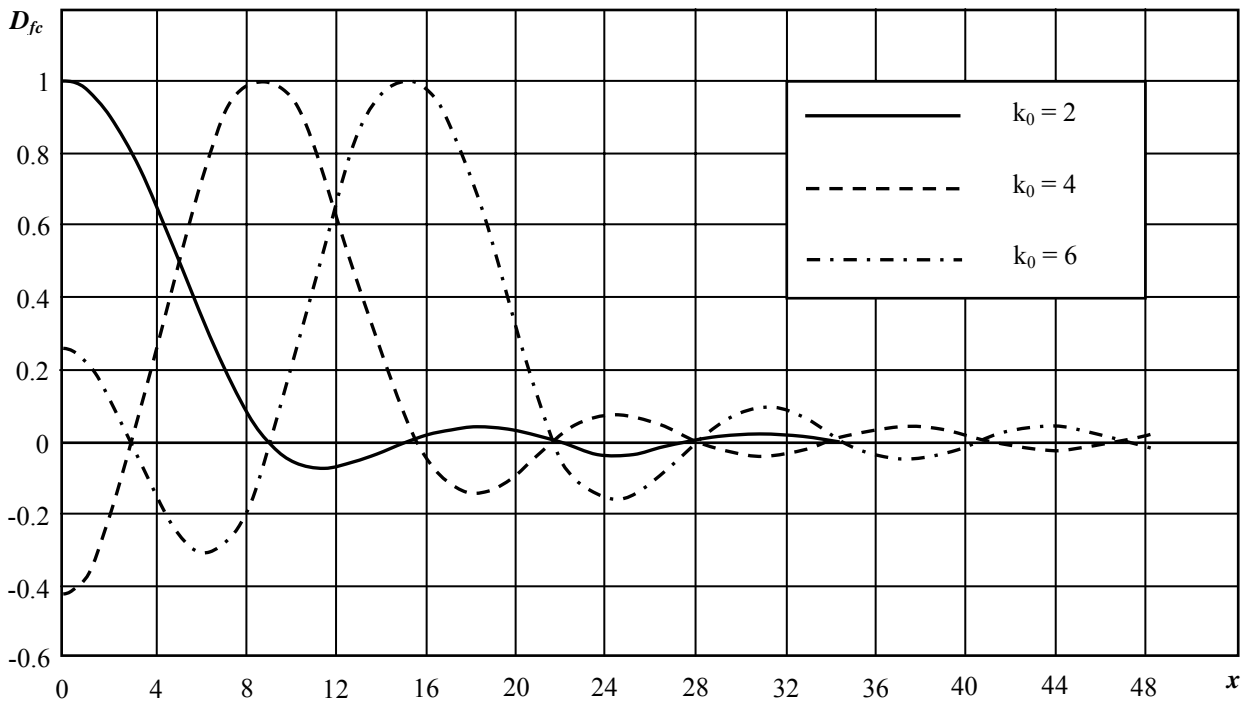

Fig.13. Diagrams for calculation of the radiation patterns for the transducers (Fig. 7 and 8) with fixed edges and with cosinusoidal distribution of vibrations

In Fig. 14, the dashed line corresponds to the calculated radiation pattern of the transducer with fixed edges and the continuous line in Fig. 14 shows the experimentally measured radiation pattern of the transducer. This radiation pattern is calculated using Eq. 9. In this case, the transducer (Fig. 3) consists of an aluminum plate measuring 81.0x44.0x1.0 mm and a

piezoelectric ceramic plate 60.0x20.0x1.0 mm. The operation frequency of this transducer in air is 19 kHz.

From Fig. 14 we can see that the experimental radiation pattern of the piezoelectric ceramic rectangular thin-plate transducer in cosinusoidal flexural vibration under free-boundary conditions is in satisfactory agreement with the calculated results.

To aid the design of a transducer (Fig. 3) with one piezoelectric ceramic plate, a diagram for a calculation of the width of the ceramic plate and the width of the elastic metal plate is presented in Fig. 15. The diagram applies when the thicknesses of the ceramic plate and the elastic

plate are both equal. It is clear that when designing unidirectional transducers using such components, the angle between the two main leaves of radiation should be 90 degrees.

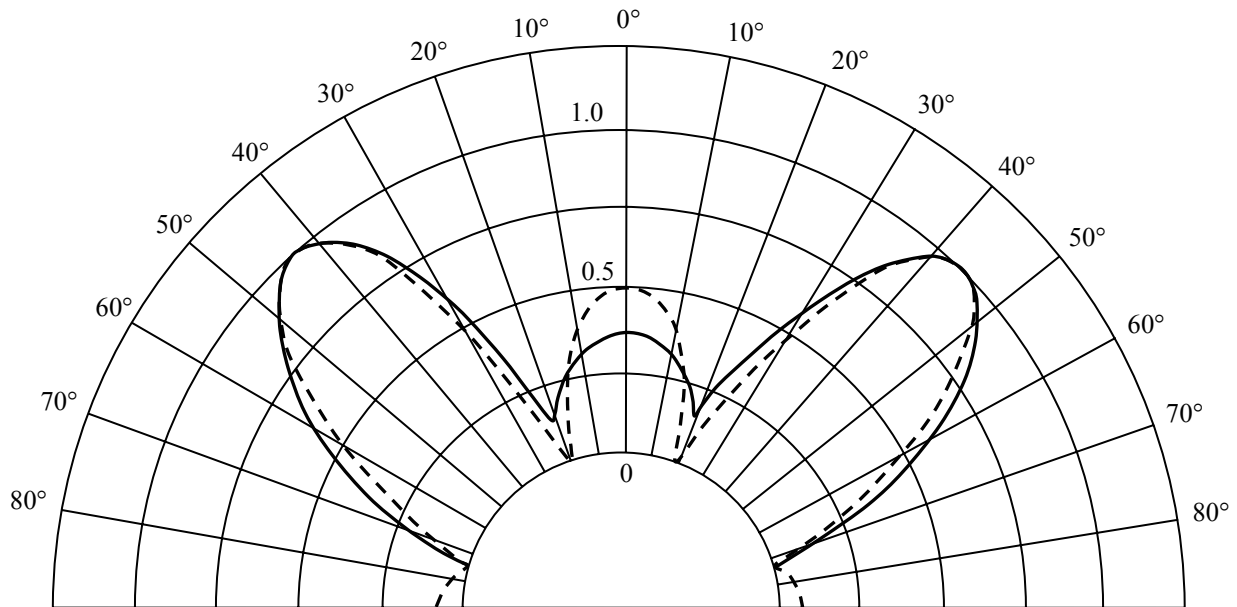

Fig.14. Radiation patterns of the transducer (Fig. 3) with fixed edges

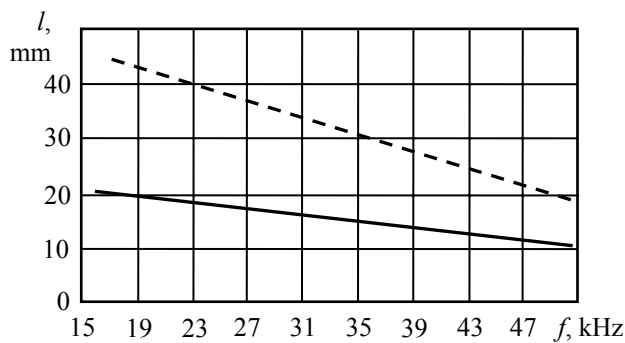

Fig.15. Diagram for calculating the width of the ceramic plate and the width of the elastic metal plate. The dotted line represents the width of an elastic plate and the continuous line - width of the piezoelectric ceramic plate.

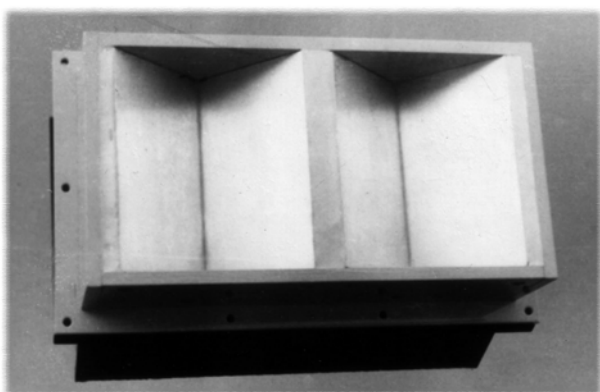

Fig.16. The actual image of the unidirectional acoustic antenna composed of symmetric bimorph piezoelectric ceramic transducers with fixed edges (Fig. 3)

The actual image of the unidirectional antenna composed of symmetric bimorph piezoelectric ceramic transducers with fixed edges (Fig. 3) is presented in Fig.16.

Conclusions

Experimental results show that the measured radiation pattern of the transducer in cosinusoidal flexural vibration is similar to the calculated radiation pattern.

The transducers in cosinusoidal flexural vibration, like the transducers in sinusoidal flexural vibration [1], may also be used successfully when designing acoustic antennas for various measurements in a gas environment.

The bimorph rectangular transducers with straight and parallel nodal lines of vibrations can successfully be used when designing unidirectional acoustic antennas.

References

1. **Petrauskas A.** A study of the design and the radiation patterns of rectangular bimorph acoustic transducers with thin piezoelectric ceramic plates. ISSN 1392 – 2114 Ultragarsas (Ultrasound). Kaunas: Technologija. 2008. Vol.63.No 4. P. 57-65.
2. **Chen Chao, Tin-Yan Lam, Kin-Wing Kwok and Helen Lai-wa Chan** Piezoelectric micromachined ultrasonic transducers with rectangular diaphragms for dual-frequency applications. Proc. SPIE. 2007. Vol. 6556. 65561J. DOI:10.1117/12.723610.
3. **Baborowski J., Ledermann N., Muralt P., Schmitt D.** Simulation and characterization of piezoelectric micromachined ultrasonic transducers (pMUTs) based on PZT/SOI membranes. Int. J. Comp. Eng. Sci. 2003. Vol. 4. P. 471-475.
4. **Barone A., Gallego-Juarez J. A.** On a modification of vibrating flat plates in order to obtain phase-coherent radiation. Acustica. 1970. Vol. 22. P. 187-188.
5. **Gallego-Juarez J. A., Rodriguez G., San Emeterio J. L., Sanz P. T., Lazaro J. C.** An acoustic transducer system for long-distance ranging applications in air. Sensors and actuators: A. physical. 1993. Vol.37-38(C). P. 397-402.
6. **Gallego-Juarez J. A.** Piezoelectric ceramics and ultrasonic transducers. Journal of Physics E: Scientific Instruments 1689. Vol. 22 (10). Art. No. 001. P. 804-816.
7. **Lin S.** Study on the high power air-coupled ultrasonic compound transducer. Ultrasonics. 2006. Vol.44 (SUPPL.). P. e545-e548.

8. **Lin S.** Piezoelectric ceramic rectangular transducers in flexural vibration. IEEE Transactions on ultrasonics, ferroelectrics and frequency control. 2004. Vol. 51. No.7. P. 865-870.
9. **Lin S.** Study on the Langevin piezoelectric ceramic ultrasonic transducer of longitudinal-flexural composite vibrational mode. Yadian Yu Shengguang /Piezoelectrics and acoustooptics. 2005. Vol.27. No.6. P. 620-623.
10. **Shu-Yu L.** High power air-borne ultrasonic transducers. Acta physica Sinica (overseas Edition). 1999. 8 SUPPL. No.1. P. S38-S41.
11. **Danilov V. N., Ermolov I. N.** Estimation of the length of the near zone of a rectangular transducer. Russian Journal of nondestructive testing. 2003. Vol.39. No.5. P. 333-338.
12. **Xian X., Lin S.** Study on the compound multifrequency ultrasonic transducer in flexural vibration. Ultrasonics. 2008. Vol. 48. No.3. P.202-208.
13. **Shuyu L.** Study on the radiation acoustic field of rectangular radiators in flexural vibration. Journal of Sound and Vibration. 2002. Vol.254. No.3. P. 469-479. doi:10.1006/jsvi.2001.4095.
14. **Shuyu L.** Study on the flexural vibration of rectangular thin plates with free boundary conditions. Journal of Sound and Vibration. 2001. Vol.239. No. 5. P. 1063-1071.
15. **Shuyu L** Equivalent circuits and directivity patterns of air-coupled ultrasonic transducers. JASA. 2001. Vol.109. No. 3. P. 949-957.
16. **Farag N. H., Pan J.** Free and forced in-plane vibration of rectangular plates. JASA. 1998. Vol.103. No.1. P. 408-413.
17. **Sung C.-C., Jan J. T.** The response of and sound power radiated by a clamped rectangular plate. Journal of Sound and Vibration. 1997. Vol.207. No.3. P. 301-317.
18. **Li N.** Forced vibration analysis of the clamped orthotropic rectangular plate by the superposition method. Journal of Sound and Vibration. 1992. Vol.158. No.2. P. 307-316.
19. **Warbuton G. B.** The vibration of rectangular plates. Proceedings of Institute of mechanical engineers. 1954. Vol.168. P. 371-381.
20. **Rayleigh L.** Theory of sound.(two volumes). New York: Dover Publications; 1987second edition. 1945 re-issue.
21. **Szilard R.** Theory and analysis of plates. Classical and numerical methods. New Jersey: Prentice-Hall.1966. P. 435.
22. **Jiang H., Adams D. E., Jata K.** Material damage modeling and detection in a homogeneous thin metallic sheet and sandwich panel using passive acoustic transmission. Structural Health Monitoring. December 2006. Vol. 5, Issue 4. P. 373-387. doi:10.1177/1475921706067764.
23. **Ruzzene M.** Vibration and sound radiation of sandwich beams with honeycomb truss core. Journal of Sound and Vibration. 2004. Vol.277. No.4-5. P. 741-763. doi: 10.1016/j.jsv.2003.09.026.
24. **Sorokin S. V.** Vibrations of and sound radiation from sandwich plates in heavy fluid loading conditions. Composite structures. 2000. Vol.48. No.4. P.219-230. doi:10.1016/S0263-8223(99)00103-8.
25. **Babic M.** A 200-kHz ultrasonic transducer coupled to the air with a radiating membrane. Ultrasonics, ferroelectrics and frequency control. IEEE Transactions. 1991. Vol.38. P.252 – 255.
26. **Brissaud M.** Theoretical modelling of non-symmetric circular piezoelectric bimorphs. Journal of micromechanics and microengineering. 2006. Nr. 16. P.875-885.
27. **Yamane H., Kawamura M.** Sound sources with vibration plates in flexural modes and reflection plates for airborne ultrasonics. J. Acoust. Soc. Japan. 1976. Vol. 32. No.2. P.83-91.
28. **Bindal V. and Chandra M.** An improved piezoelectric ceramic transducer for ultrasonic applications in air. Archives of acoustics. 1982. Vol. 7. No.3-4. P. 281-286.
29. **Honda Y., Matsuhisa H. and Sato S.** Radiation efficiency of a baffled circular plate in flexural vibration. Journal of Sound and Vibration. 1983. Vol.88. No. 4. P. 437-446.
30. **Barone A., Gallego-Juarez J A.** Flexural vibrating free-edge plates with stepped thickness for generating high directional ultrasonic radiation. JASA. 1972. Vol.51. No.3. P.953-959.
31. **Germano C. P.** Flexure mode piezoelectric transducers. IEEE Transactions on audio and electroacoustics. 1971. Vol. AU-19. No.1. P.6-12.
32. **Matsuzava K.** Sound sources for producing intense ultrasonic fields in small regions in air. – In: Eighth International Congress on Acoustics. London. 1974. Vol.11. P.709.
33. **Петраускас А., Домаркас В.** Особенности работы прямоугольных биморфных электроакустических преобразователей со свободными краями (in Russian). Вильнюс: Минтис. Ультразвук (Ultrasound). 1974. No.6. P.103-108.
34. **Petrauskas A.** Investigation and construction of measuring transducers for ultrasonic devices using flexural vibrations. Ph. D. thesis. Kaunas. 1975. P.147. (in Russian).
35. **Домаркас В., Мажонас А., Петраускас А.,** Изгибные колебания составных прямоугольных пьезопреобразователей. ISSN 0369-6367 (in Russian). Вильнюс: Минтис. Ультразвук (Ultrasound). 1989. Nr.21. P.43-50.
36. **Домаркас В., Петраускас А.** Колебания асимметричных биморфных пьезоизлучателей (in Russian). Вильнюс: Минтис. Ультразвук (Ultrasound). 1976. No.8. P.57-64.
37. **Домаркас В., Петраускас А.** Биморфные пьезокерамические преобразователи для измерений в газовых средах (in Russian). Вильнюс: Минтис. Ультразвук (Ultrasound). 1978. No.10. P.55-64.
38. **Домаркас В.** Эквивалентные четырехполосники асимметричных биморфных пьезоэлектрических преобразователей. ISSN 0369-6367 (in Russian). Вильнюс: Минтис. Ультразвук (Ultrasound). 1984. No.16. P.20-30.
39. **Теумин Н. И.** Ультразвуковые колебательные системы (in Russian). Moscow: Машгиз. 1959. 332 с.
40. **Бабаков И. П.** Теория колебаний (in Russian). Moscow: Госиздат технико-теоретич. литературы. 1958. P. 627.
41. **Kikuchi E.** Ultrasonic transducers (in Russian). Moscow: Mir. 1972. P.424.
42. **Домаркас В., Мажонас А., Петраускас А.** Исследование характеристик направленности пьезопреобразователей изгибных колебаний. ISSN 636-6367 (in Russian). Вильнюс: Минтис. Ультразвук (Ultrasound). 1983. No.15. P.48-51.
43. **Мажонас А., Петраускас А.** Оптимизация характеристик направленности акустических антенн. ISSN 0369-6367 (in Russian). Вильнюс: Минтис. Ультразвук (Ultrasound). 1984. No.16. P. 84-87.
44. **Miniialga V., Petrauskas A.** Estimation of directivity patterns of two rectangular acoustic radiators oriented at various angles. ISSN 1392 – 2114 Ultragarsas (Ultrasound). Kaunas: Technologija. 1998. No1(29). P. 20-23.
45. **Домаркас В., Петраускас А. Мажонас А.** Многоэлементные пьезокерамические преобразователи изгибных колебаний. ISSN 636-6367 (in Russian). Вильнюс: Минтис. Ультразвук (Ultrasound). 1981. No.13. P.24 - 29.
46. **Petrauskas A.** The optimization of directional characteristics for acoustic antennas from piezoceramic rectangular bimorph transducers in flexural vibration.. ISSN 1392 – 2114 Ultragarsas (Ultrasound). Kaunas: Technologija. 2007. No 1(62). P. 26-32.

A. Petrauskas

Stačiakampių simetrinių bиморфinių pjezoelektrinių keitiklių su kosininiu virpesių pasiskirstymu ant paviršiaus konstrukcijos ir spinduliuotės charakteristikos

Reziumė

Tirtos stačiakampių simetrinių bиморфinių pjezokeraminių keitiklių, kai virpesių išsidėstymas ant jų paviršiaus aprašomas kosinuso funkcija, konstrukcijos ir jų spinduliuotės charakteristikos. Pateiktos tokių keitiklių su laisvais ir įtvirtintais kraštais diagramos spinduliuotės kryptinėms charakteristikoms apskaičiuoti. Norint, kad tokių keitiklių darbas būtų efektyvus, reikia suderinti pjezokeraminių paketų virpesius su elastinių plokštelių, prie kurių šie paketai pritvirtinti, virpesiais. Apskaičiuojant tokių keitiklių kryptines charakteristikas, būtina nustatyti jų virpesių formą. Nustatant daugiaelemečių lankstymosi virpesių keitiklių spinduliuotės charakteristikas, galima laikyti virpesių pasiskirstymą ant keitiklio paviršiaus harmoniniu. Bиморфinių keitiklių spinduliuotės kampas priklauso nuo akustinių bangų ilgio santykio keitiklio paviršiuje ir darbo aplinkoje. Nedidelis keitiklio spinduliuotės kampo pokytis gali priklausyti ir nuo darbo dažnio. Pateikta konkreti vienkryptės akustinės antenos konstrukcija, sudaryta iš stačiakampių simetrinių bиморфinių keitiklių gardelės. Pateikta spaudai 2009 03 04

DOI: 10.5755/j01.u.64.1.17094