

Experimental-diagnostic investigation of operation parameters variations of industrial-technological system

A. Čereška

Vilnius Gediminas Technical University, Department of Machine Building,

Basanavičiaus str. 28, LT-03224 Vilnius, Lithuania,

Phone: +370 5 2370573, +370 5 2370594, Fax. +370 5 2745043, E-mail: audrius@me.vgtu.lt

Abstract

Defibrator of vertical working of wood chip nemalining and milling is investigated in this work. The principle of defibrator operation is described and principal and functional schemes are given.

Diagnostic investigation of defibrators operation parameters was carried out changing expenditure of defibrator steam and influencing different unacceptable factors. The obtained results of measurements are summarised and its analysis is done.

The more optimal work regimes of the investigated system are determined, that are secured the most productivity of work of searching system maximum by getting results of the analysis. Interdependence of work parameters of investigated mechanism is determined.

Keywords: experimental-diagnostic research, productivity of work, load of system, analysis

Introduction

Defibrators are bestowed for nemalining of wood filling. The first defibrators were with stony discs or with round stones that were remodelled wood, it feeding with a chain speed [1].

Modernising production mills with metallic discs were constructed that secured better labour productivity, quality of mass milling and lateral things were plumped into mass less [2, 3, 4].

Mills of different constructions with vertical and horizontal axle were developed too. Vertical milling discs are distributing nemalining equally on all surface of milling. Mills of such constructions becomes more popular for or milling of concentration of a high mass, but their maintenance and repair are more difficult comparing with mechanisms with vertical discs.

Nowadays qualitative milling is achieved during two or three levels of milling [5, 6]. There are attempts to get a good milling quality during one level of milling.

The defibrators that are produced now are similar or of identical construction.

There are attempts, that the technological process of milling would be shortened, that nemalining is performed at a lower temperature and consumption of vapour, that thermoelectricity are distinguished, that is necessary for nemalining would be lesser [7].

Economizing a power reserve it is tried to burden the technologic system maximum, but that shortens a work resource of mechanisms, working long at maximum and with over maximum regimes sometimes, decreases a margin of safety, also mechanisms work unstably, there may start unacceptable vibrations too, which may make resonance [8]. Resonant vibrations start suddenly and dragging on in particular time may happen sudden breakdowns, that is to cause inconsiderable damages.

In order to obtain it, it is necessary to distinguish prime parameters of the technological process, that influence work parameters of wood nemalining defibrators most and to determine the optimal work regimes [9].

Object of research and its principle of working

The object of the research is the defibrator of vertical working. It is used in production of wood splint for breaking of chip, were pressure of water vapour is 8-10 bars and temperature is 443-456 K. The degree of chip milling is 19,5-20,0 def/s, the productivity is 130-150 t/day.

All nodes of the defibrator are fixed by a concrete base. Roll of the rotor is embedded in two nodes of bearings that are assembled into frame. In the forward node of bearings that are two supporting bearings; in the final node then is one radial globular bearing. Steamy chip is given from the chamber of steaming 2 to the milling chamber 5 with two male screws. From the milling chamber 5 through tailpipe 10 mass is transported to the reservoir of mass 7, where successive technological processes take place [3].

A general view of the investigated system is given on Fig. 1, and the principal scheme of working - in Fig. 2, 3.



Fig. 1. General view of investigated object

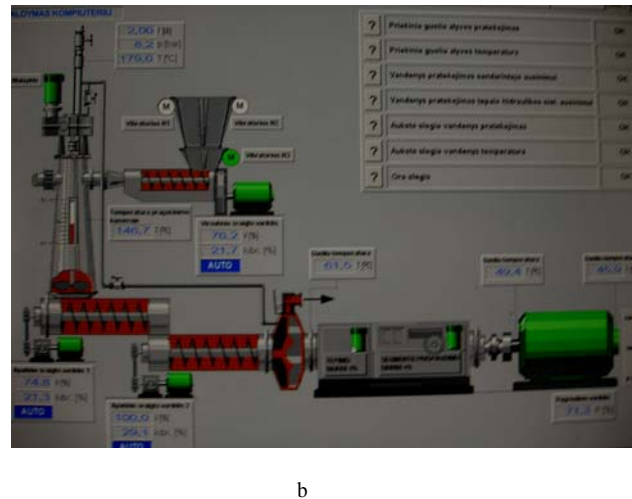
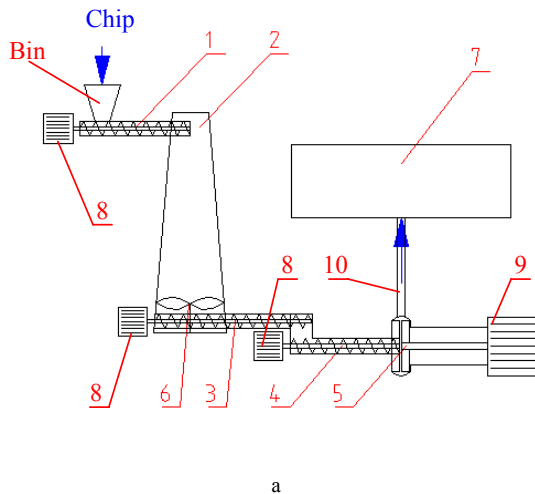

Fig. 2. Object of investigation: a- principle scheme, 1 – screw of supply of steaming camera, 2 – steaming camera, 3 – the first screw of supply, 4 – the second screw of supply grinding camera, 5 – camera with two discs, 6 – stirrer, 7 – reservoir of defibrating mass, 8 – electromotor, 9 – electromotor, 10 – tube of exhaust, b – computer – based scheme in the monitor screen.

The prepared chip is kept in a bin. From the bin through opening 1 it is poured over the upper supply screw of the defibrator 2, which is rotated by of electromotor, is moved through frame of screw to the chamber of steaming 3. In the chamber of steaming a chip is damped by steam of a high pressure 9-10 bars. The temperature in chamber of steaming supported 150-165⁰ C. In the chamber of steaming the chip is damped, mixing in dolly. Damping with steam is very important and from it depends degree of a milling mass, and damping is depending on the temperature of steam in the chamber of steaming and consumption of steam. From the first lower screws of the chamber of steaming 3 a chip is withdrawn and is transmitted to the second lower screw 4 that pushes a chip to the chamber of milling 5. The chip to the chamber of milling with the screw is pushed through opening of a still disc, so the chip is plumped between the segmental discs and grinded; it is eliminated with a turning movement from the milling chamber through a very little opening between discs. The disc of milling chamber is rotated with one powerful 600 kW electromotor 9 only, that moment of turning to roll is transmitted through the muff. The electromotor fixed to the concrete base. The speed of segments rotation is 1100-1460 rev/min. The diameter of discs is 960 mm. It is very important pressing of segments and distance between it for a process of control that is controlled by hydraulic mechanisms of pressing. From the chamber of milling is eliminated through the tailpipe 10 to the reservoir of mass 7. The defibrator is controlled by a computer-based desk of control that indicates separate working characteristics of the defibrator and the state of the defibrator generally.

Quality and costs of a production are dependent on a defibrators quality of work and productivity.

System of motors control

Increasing and decreasing workload of the electromotor, its workload is measured and analogical

signal is transmitted to DAC (DAC – device of analysis of analogical signal). Analogue signal DAC is transformed to electrical and with the help of amplifier is transmitted. The processed signal is transmitted to PC, where signal is analysed. Sifting information, it is transmitted to the block of control, then is given a command to accelerate or to slow down electro motors rotation. Block of control is processing information and gives signal to controllers, which control motors or slow down rotation.

If segments are fried and it is not supposed to grind amount of feeding mass in the camera of grinding, then the basic motor is burdened over 100 % and this is not allowed. The computer getting information that loads are over permissible standards, gives command to control block to decrease feeding of chip into grinding camera. Block of control gives command to the controller that it could decrease rotations of screw electromotor of the first supply. If workloads of the basic motor of the grind camera are small, then in that case block of control increases rotation speed of supply screw electromotor. When segments of the grind camera are not supposed to grind chip, the second screw of supply is getting large loads too. When segments are not supposed to grind chip and the second screw is providing chip further, the electromotor is burdened very much too. The computer perform analyses of loads and is sending command to block of control that it decreasing feed of a chip deal.

The basic work characteristics of the electromotor 9, which is rotating discs of grinding with segments are the following:

- Voltage – 380 V;
- Power of the electromotor – 600 kW;
- Frequency of revolution – 1500 rev/min;
- Current of rotor – 5,8 A;
- Resistance of rotor – 2,92 Ω.

Changing operation conditions subject to deal with steam and initial characteristics operation conditions of the electromotor are changed also.

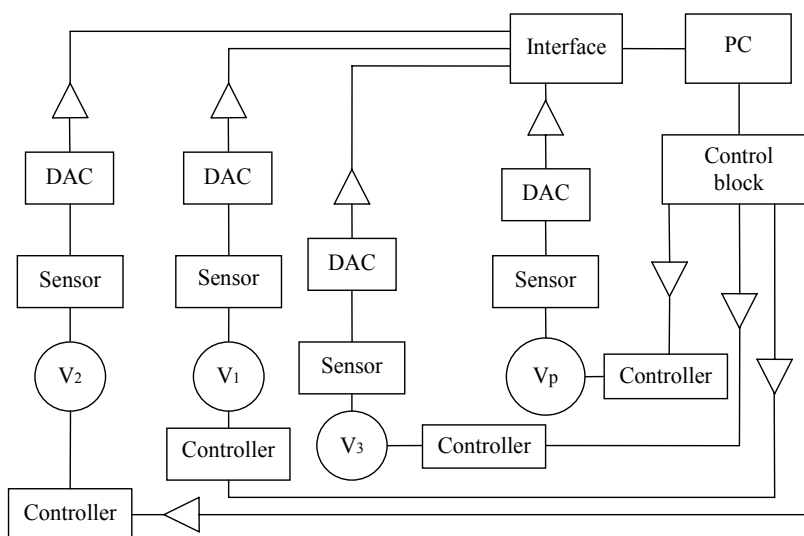

Fig. 3. Principal scheme of electromotors control of the defibrator: V_p – basic electromotor(9); V_1 – electromotor of the first screw, V_2 – electromotor (4) of the second screw, V_3 – electromotor (1) of the upper screw, DAC –device of analysis of analogical signal, Δ – amplifier of signal, PC –personal computer

Course of experimental investigations

A special computer programme is used for measurements, which gives instantaneous work parameters of the equipment at varying workloads. Special transducers are used for evaluation of workloads.

During investigation we have tried to find changes of work parameters by changing consumption of steam. Consumption of steam was changed and it was fixated how it changed the load of electromotors and what was productivity of work of screws, which supply chip.

The work characteristics of the defibrator were investigated at the following steam consumption:

1. Work parameters of the equipment were measured at 0.5 t/h;
2. Work parameters of the equipment were measured at 1.0 t/h;
3. Work parameters of the equipment were measured at 1.5 t/h;
4. Work parameters of the equipment were measured at 2.0 t/h.

During experiments were obtained results, their analysis performed and more optimal regimes of work of investigated system was determined, which depend on the consumption of steam.

Results of measurements and their analysis

The results during measurements obtained are given in graphs (Fig. 4, 5, 6, 7, 8). Analysis of the measurement results was carried out.

The main problem of the investigated system is that at small consumption of steam, it rises cameras of the main grind and load of other electromotors work which is supplying chip and is depended on a damp of the chip.

Work stability, reliability and small running costs are necessary for any mechanical system.

The main problems of the investigated system are determination and more optimal work parameters which are found from diagnostic measurements and their analysis only.

When the consumption of steam is 0,5 t/h, spread of electromotor load is 30-41 % of the lower first screw 3 and it is very big and it exceeds values of the nominal load. Spread of electromotor load of the screw 4 is 30-43 %, it is very big too and it is not neglectable probability that the screw may stop. When loads of the screw are very big, so speed is small. The speed of the screw 3 is 15-29 %, the speed of the screw 1 is 20-33 %, and spread of load of the main electromotor 9 is 80-110%. The screw 4 works with very big loads and the main electromotor 9 is not fit to grind deal of plenum ship. When the consumption of steam is 0.5 t/h, the equipment works badly and loads of motor are decreased automatically. Chip is milled badly, because it is damped insufficiently and segments are grinded considerably harder. For this reason loads of the main electromotor 9 rise in a room of grind, because it is not made to grind a chip. Mass is produced 25 % only from of full power of equipment. Work of the segments is very ineffective, unreliable and there is a high probability, that exceeding marginal loads could stop screws of chip innings automatically. Increasing load of the main electromotor 9 to 110 % it could stop automatically too. At such loads of the electromotors, it is unadvisable to work, because the system is operated at big loads on the equipment and its work is not unstable, but and unreliable also. It is not worth to economize steam, because when system works with a full power, the mass is obtained only 25 %.

When the consumption of steam is 1.0 t/h, spread of load electromotor of the screw 3 is 24-28%, spread of load electromotor of the screw 4 is 28-35%, load of the screw 1 is 24-28%, the speed of the screw 3 is 29-42%, the speed of the screw 1 is 33-46%, and spread of the load of the main electromotor 9 is 86-105%.

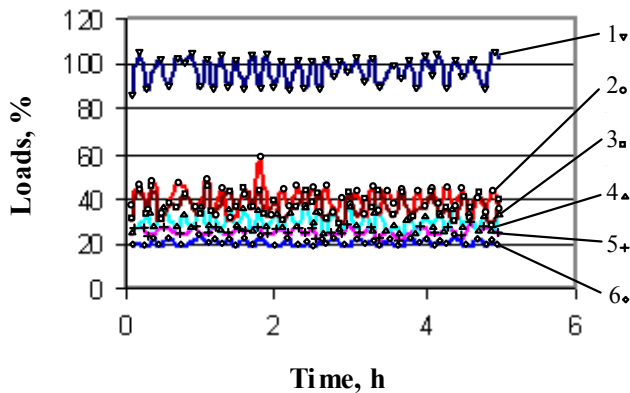

Fig. 4. Work parameters of the defibrator, when consumption of steams is 1.0 t/h: 1 - load of the main electromotor (9); 2 - speed of upper screw (1); 3 - speed of lower screw (4); 4 - load of upper screw (1); 5 - electromotor load of the first screw (8); 6 - electromotor load of the second screw (8)

The main electromotor 9 works heavily, loads of the electromotor are often decreased, because they exceed marginal possible loads of the electromotor. Loads of the electromotors of the screws 1, 3, 4 are very big - 24-35% and they are enlarged, because the normal loads are 20-25%. The screws works very unstably, loads and speed of revolution 33-46 % are balanced especially strongly. The loads are increased, when the room of grinding could not grind chip for its insufficient damp, and the screws are burdened, because segments are not made to grind chip, therefore loads of electro motors are increased and speed is decreased. Recourse is to increase consumption of steam only, because the equipment works very heavily and unstably, therefore the work is unproductive, the mass is produced only 50 % from a full potential of the equipment.

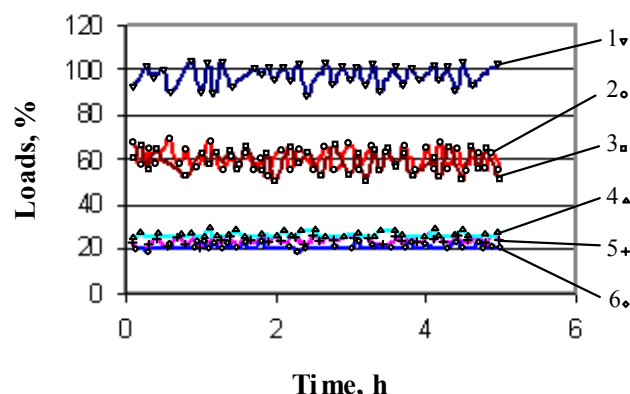

Fig. 5. Work parameters of the defibrator, when consumption of steams is 1.5 t/h: 1 - load of the main electromotor (9); 2 - speed of upper screw (1); 3 - speed of lower screw (4); 4 - load of upper screw (1); 5 - electromotor load of the first screw (8); 6 - electromotor load of the second screw (8)

When consumption of steam is 1.5 t/h, the load of the screw 3 electromotor is 22-26 %, spread of the screw 4 electromotor load is 19-23 %. The load of the screw 1 is 25-

28 %, the speed of the screw 3 is 62-51 %, the speed of the screw 1 is 65-54 % and spread of the main electromotor 9 load is 88-104 %. It can be seen from the work results, that loads of the main electromotor 9 are changed considerably more frequently and the spread of the motor load is more major than in other cases, then the electromotor works with such consumption of steam not so stable how being 2,0 t/h. The main electromotor 9 is not fit to grind chip, when the screw 3 provides 75-80 % and the main electromotor 9 works with enlarged loads 101-105 % very often, simultaneously the screw 4 supplies chip to grind room and the electromotor of the screw 4 works with enlarged loads. The block of control increases the speed of chip serving and determines speeds of screws 62-55 % automatically from the obtained signals of loads. Loads are increased for a insufficient irrigation of a chip and grinding chip is not easy, therefore segments are not made to grind chip and screws move more chip already what burdens electromotors additionally.

When expenditure of steam is 2.0 t/h, the main electromotor 9 works sufficiently well, spread of loads is 95-102 %. But the load exceeds permissible norm sometimes that is, loads exceed 100 %. The load of the screw 3 electromotor is 20-24 %. The load of the screw 4 electromotor is 18-20 %. The load of the screw 1 is 24-30%. The speed of the screw 3 is 82-73 %. The speed of the screw 1 is 84-74 %. The main electromotor 9 works with a full power keeping good characteristics, such characteristics, such as for the screw 3, the speed of rotation of which is 80 % and chip is damped sufficiently.

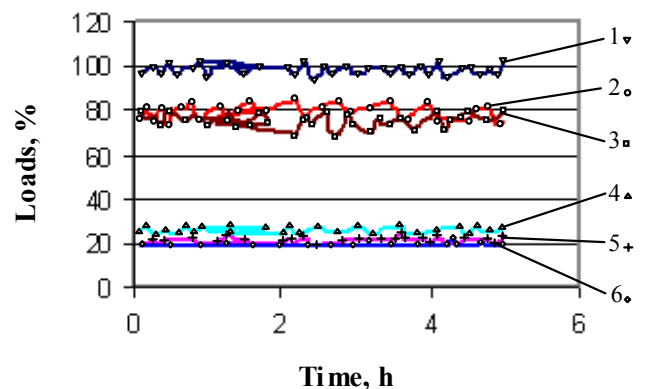

Fig.6. Work parameters of the defibrator, when consumption of steams is 2.0 t/h: 1 - load of the main electromotor (9); 2 - speed of upper screw (1); 3 - speed of lower screw (4); 4 - load of upper screw (1); 5 - electromotor load of the first screw (8); 6 - electromotor load of the second screw (8)

Work productivity of the main electromotor 9 is very important, because subject to load of motor, and it affects longevity of service and quality of work of all system.

The electromotor which is leaded over permissible norms works unstably and could be switch off at any moment automatically and that stops process of production. Spread of load of the electromotor 9 grind room, subject to irrigation of a chip, is shown in Fig. 8.

Chip is damped with steam before giving the chip to the defibrator. The steam is expensive, therefore it is

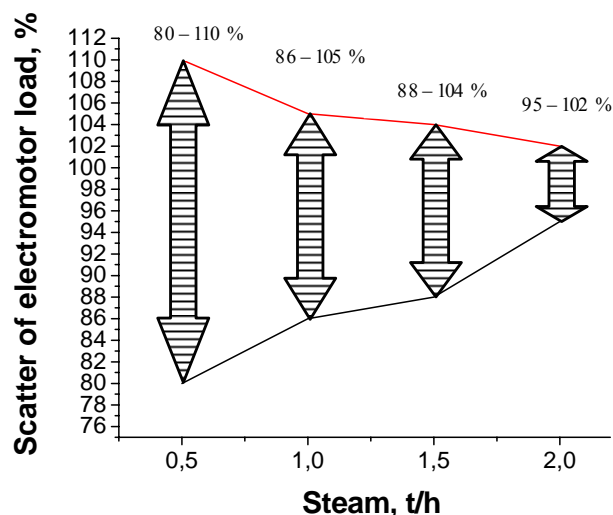

Fig. 7. Spread of electromotor (9) load, subject to irrigation of chip

economised as much as possible. How the productivity of made mass of industrial – technologic system depends on a feed of steam is given in Fig. 9.

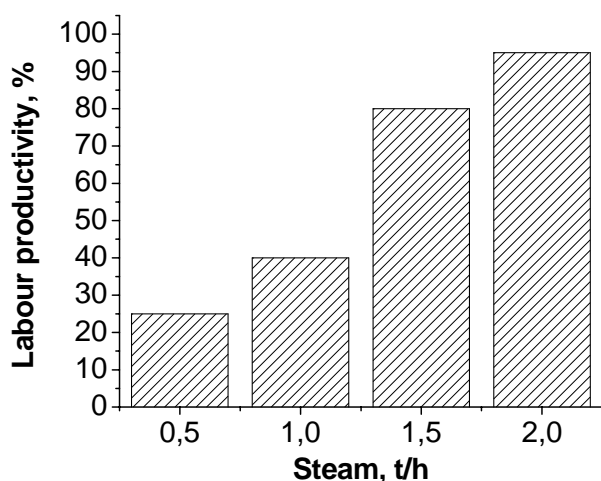

Fig. 8. Dependence of production productivity from deal of feeding steam

It can be seen from the results that are given in the graphs (Fig. 7, 8), that more moistened chips are supplied for grind, the smaller loads affect the electromotor 9, that is, the rotating segments of grind and it is major productivity of work of all system.

Summation of results

It is estimated the best characteristics of work of the analysed equipment - of the defibrator are different at different expenditures of steam.

The equipment begins to work heavily already at 1.5 t/h consumption of steam, major loads start, the equipment with a full power is not in a state to work, therefore speeds of screws are decreased and making of mass is decreased already by 15 %.

From the analysis follows, that spread of the main motor loads is 86-105 %, loads of motor are varied more and more frequently, then at such 1.0 t/h loads of steam our equipment worked not so stable, how it is at 1.5 t/h.

More effective work of the analysed equipment is when the consumption of steam is 1.65-1.85 t/h primarily there is smaller expenditure of steam, because production is very expensive. The electromotor is loaded more already, but it is normal and such work is stable. Speeds of screws are decreased a little by 70-57 %, the electromotors are loaded 20-26 %, but loads are small and equipment works stable, making of mass is balanced 90-85 %.

The 1.5 t/h consumption of steam is recommended to use now when making is necessary than 85 %, because with the 100% potential the defibrator is not in a state to work. It is necessary to decrease passing speed of screws chip for increased loads of the main electromotor and for additional loads of screws.

When the consumption of steam is 1.0 t/h, the work of the equipment is unstable, because loads of the main electromotor and of the electromotor of screws rotation are very big. The equipment in these regimes does not work in a production almost never, because the work of segments is not effective and the equipment is very laden, the result – different breakdowns. Productivity is very small, less than 40 %.

The best working characteristics are when the consumption of steam is 2.0 t/h.

When the consumption of steam is 0.5 t/h and system works with a full potential, the obtained mass is 25 % only, therefore the worst work characteristics of the analysed industrial – technological system are when the consumption of steam is 0.5 t/h.

Steam is expensive, it is necessary to economise it as much as possible, but when a dryer mass of chip is gotten to the room of grind, the discs of grind and screws, that are pushing the mass of chip are much more worn and the electromotors are working with maximum loads.

It is important, that mechanisms should not be overloaded too long over permissible standards of work regimes.

Conclusions

1. When consumption of steam is 1.0 t/h, the work of the equipment is unstable, because loads of the main electromotor and feeding of screws are very big. In these regimes the equipment almost never works, because work of segments is ineffective and the equipment is very laden, the result – different breakdowns. Productivity is very small, about 40 %.
2. When consumption of steam is 1.5 t/h the equipment works unstably starts, the major loads, the equipment with a full power is not in a state to work, why the speeds of screws are decreased and making of mass is decreased by 15 %.
3. It is recommended to use 1.5 t/h consumption of steam now, when the productivity must be lower than 85%, because with a 100% power the defibrator is not in a state suitable to work. For increased loads of the main electromotor and for additional loads of

screws it needs to decrease the speed of a chip passing the screws.

4. More effective work of the analysed equipment is when the consumption of steam 1.65-1.85 t/h, because the consumption of steam is lower. The basic electromotor is burdened normally and this work is stable. The speeds of screws are decreased marginally 70-57 %, its electromotors are burdened 20-26 %, but the loads are small and equipment works stable, productivity is balanced on 90-85 % limits. So, from the obtained results follow, that the most effective expenditure of steam of the defibrator is 2.0 t/h, that is the best working characteristics are obtained when the consumption of steam is ~ 2.0 t/h.
5. The worst working characteristics of the investigated industrial – technologic system are when the consumption of steam is 0.5 t/h.

References

1. Легоцкий С., Гончаров В. Расмалывающее оборудование. Москва. Лесная промышленность. 1991. 127 с.
2. Пери Р. Технология древесной массы. Минск. 2003. 327 с.
3. Зуйков А. Современные тенденции в развитии производства дефиберной массы. Москва. Лесная промышленность. 1997. 15 с.
4. Добровольский П. П. Производство древесной массы из щепы. Москва. Лесная промышленность. 1991. 77 с.
5. Галкин Н. Особенности эксплуатации дефибраторов. Москва. Лесная промышленность. 1999. 144 с.

6. Пузырев С. А. Производство различных древесных масс и факторы влияющие на их свойства. Москва. Лесная промышленность. 1990. 18 с.
7. Chiag Michigan C. Tech scientist tests progress. Timber producer. 1996. P.9.
8. Vekteris V., Čereška A. Investigation of resonance frequencies of rotor system with segmental sliding bearings. Ultragarsas. 2007. Vol.62. No. 3. P. 53-57.
9. Vekteris V., Čereška A. Diagnostical measurements of elements of mechatronical system. International Conference of DAAAM Baltic Industrial Engineering – Adding Innovation Capacity of Labour Force and Entrepreneur, Proceedings, Tallinn, Estonia. 20 – 22 April 2006. P.183-187.

A. Čereška

Gamybinės-technologinės sistemos darbo parametrų pokyčių eksperimentiniai-diagnostiniai tyrimai

Reziumė

Tirtas medžio skiedros plaušinimo ir malimo horizontalaus veikimo defibratoriaus. Aprašytas defibratoriaus veikimo principas ir pateiktos principinė ir funkcinė schemas. Atlikti defibratoriaus darbo parametrų diagnostiniai tyrimai keičiantis defibratoriaus garo sąnaudoms ir veikiant kitokiems nepageidaujamiems veiksniams. Matavimo rezultatai apibendrinti ir atlikta jų analizė. Iš analizės rezultatų nustatyti optimaliausi tiriamos sistemos darbo režimai, užtikrinantys didžiausią jos darbo našumą. Nustatyta tiriamojo mechanizmo darbo parametrų tarpusavio priklausomybė.

Tyrimo rezultatai pateikti grafiškai. Pabaigoje pateiktos apibendrintos išvados.

Pateikta spaudai 2008 12 5

DOI: 10.5755/j01.u.64.1.17095