

Diagnosing adhesive joints in laminar composites by ultrasonic flaw detection method

S. Spadlo

Kielce University of Technology, Poland

Al. Tysiąclecia P.P. 7, 25-314 Kielce,

Phone 48 41 3424675; E-mail sspadlo@tu.kielce.pl

Abstract

In rocket and aviation technology, thin-walled elements shaped as casings, shields passages etc. which should be ready to operate under high mechanical loads are applied. In most cases, the operational and maintenance safety is strictly correlated with the expected reliability of these elements. These constructions often operate under additional exposure to heat, erosion and chemical influence of the flowing agent and their protection is therefore necessary. Any visual inspection of the glue joint quality is practically impossible. Up to now, the parts have been inspected manually by guiding the ultrasonic probe along the surface. Lack of special equipment caused difficulties connected with precision guidance of the ultrasonic probe along the examined surface. The article presents the arrangement and components of a computer measurement setup used to examine adhesive joints of thin-walled metal casings with laminar composites. The system makes it possible not only to measure, record and analyze the ultrasonic signal but also to present a graphical representation of the examination results. The use of special so-called broadband probes which generate very short (0.2 μ s) pulses of longitudinal waves has made it possible to observe the influence which the quality of the bonding of the composite layer with the thin-walled steel casing has on the conditions of ultrasonic wave propagation inside the steel casing.

Key words: laminar composites, adhesive - bonded joints, ultrasonic inspection

Introduction

In rocket and aviation technology, thin-walled elements shaped as casings, shields passages etc. which should be ready to operate under high mechanical loads are applied. In most cases, the operational and maintenance safety is strictly correlated with the expected reliability of these elements. These constructions often operate under additional exposure to heat, erosion and chemical influence of the flowing agent and their protection is therefore necessary.

One of the possible solutions is to create layers of materials resistant to the media mentioned above, such as ceramic or composite coverage made of carefully selected materials.

Any visual inspection of the glue joint quality is practically impossible. Up to now, the parts have been inspected manually by guiding the ultrasonic probe along the surface. Lack of special equipment caused difficulties connected with precision guidance of the ultrasonic probe along the examined surface. Consequently, the quality of the obtained results heavily depended on personal skills and experience in the flaw detector servicing. This method was practically useless for determining the overall gluing quality. Moreover, it was impossible to register the results and process them graphically or analyze them.

The main difficulty of automating the inspections of the elements mentioned above was due to the lack of the probes conforming to specific characteristics and equipment that could be used in situations discussed above. Having in mind the industrial demand for this research, the author tried to solve the presented problem.

The equipment have been developed for examining the elements of the kind mentioned (pipe, conical pipe) with the internal thermal insulation padding made of a layered

composite including layers built of synthetic caoutchouc and filler mix. These layers are protected by another layer made of carbon-epoxy laminate, as shown in Fig. 1.

The detailed requirements have been defined for the examined element handling. They did not allow for dampening the inside of the pipe so that the only solution in mind was to apply the acoustic wave on the exterior of the pipe using water as the indispensable coupling medium.

The analysis of measurement conditions

The available references [1], [6], [7] mention many ways of inspecting the gluing quality for the elements made of materials displaying acoustic parameters similar to those applied in our case and having similarly defined measuring conditions. The longitudinal waves introduced perpendicularly to the inspected surface have been applied for a regular single probe, double probe (the pulse echo method) or two regular probes – transmitting and receiving one with slightly inclined acoustic axes which intersect near the place in depth where the surfaces meet; the shear waves were used as well. For thin-walled elements, the Lamb plate type waves were also applied. They were generated by one probe and received by another one after crossing the layer of the external material (pulse transmission method).

The experimental investigations which have been carried out using methods as described above for the available ultrasonic probes gave no satisfactory results for the frequencies within the range of 2 MHz – 10 MHz so that they were practically useless in the automated measuring system. This happened due to the small (0.4 mm in this case) thickness of the wall for the pipe made of maraging steel. In particular, the time of flight through the

pipe wall for the acoustic wave was 0.14-0.15 μs and it was much smaller than the typical acoustic pulse duration. This fact made it impossible to observe the acoustic phenomena occurring on the boundary surface placed on the inside of the material because it was masked by

interference with a strong pulse lasting over 1 μs which was generated by the reflection from the external surface of the examined material (water - steel boundary).

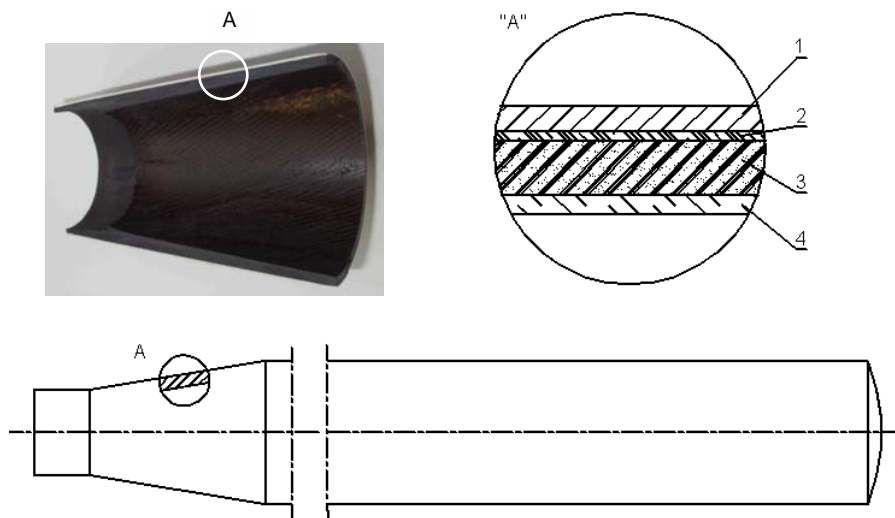

Fig. 1. Layout and a photograph of the examined structure, 1- casing of maraging steel, 2 – glue joint, 3 – layer built from synthetic gum with a filler, 4 – carbon fiber laminate

The application of special probes [3] with broadband transducers, which are able to generate very short pulses (lasting 0.2 μs) of longitudinal waves enable to observe the influence of the gluing quality for the internal layer on the wave propagation conditions in the external layer (steel). The ultrasonic wave introduced as perpendicular to the surface is subjected to multiple reflection inside the steel pipe wall generating a sinusoidal, gradually decaying ringing signal. Its frequency amounts to half of the acoustic wave cycle within the examined material so it is consequently dependent on the wall thickness and on the wave velocity for the acoustic wave propagating in the examined material. The amplitude of such resonance vibrations is considerably lower than the amplitude of the pulse reflected from the external surface because for every wave pass through the media boundary there is energy loss which increases with the difference between the wave impedances for these media. The internal steel wall of the pipe is almost totally reflecting in case of the gluing absence, which means steel to air boundary.

Proper gluing results in a much smaller difference in the wave impedances on this boundary and some wave energy passing to the glued surface is dissipated due to the strong damping material properties for such frequency. This phenomenon is responsible for the faster decay of the ringing signal. A similar method used for the assessment of the gluing quality for materials of a larger thickness (large enough to resolve pulses which are many times reflected from the surface boundary) is described in the references [7] as “measurement of the penetration range”.

Fig. 2a and 2b illustrate the first ultrasonic pulse reflected from the external pipe wall including the ringing signal in the case of gluing absence (a) and for proper gluing (b) for the ultrasonic 5 MHz probe. For the gluing absence, the level of the ringing signal was lower by - 15

dB than the amplitude of the pulse reflected from the material surface.

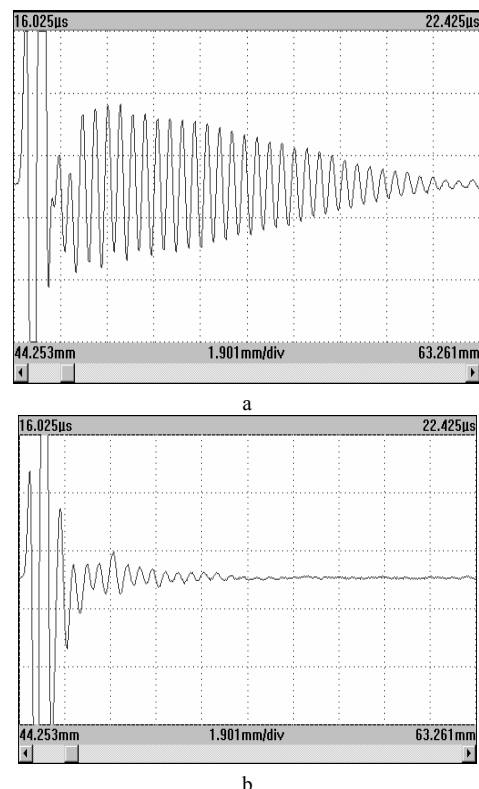

Fig. 2. First ultrasonic pulse reflected from the external surface of a steel pipe displaying the ringing effect for the gluing absence (a) and the pulse for the proper gluing (b); broadband, 5 MHz probe was used

The described phenomenon has been observed using a normal probe designed for the longitudinal 5 MHz center

frequency waves with a bandwidth of 4.5 MHz and with a 20 mm thick methyl polymethacrylate (PMM) acoustic buffer. Another observation has been taken for a normal probe designed for longitudinal 10 MHz center frequency waves with the frequency bandwidth of 8 MHz and with a 30 mm thick aluminum acoustic buffer. The width of the ultrasonic wave beam generated by the probes is dependent on the diameter of the ultrasonic transducers and it was in both cases (for the applied probe distance) approximately 12 mm.

Following the results presented above, the gluing quality has been practically assessed by measuring the ringing signal amplitude level within the 1.6 μ s time gate duration which was delayed by 1.5 μ s in reference to the beginning of the pulse reflected from the steel pipe wall.

This is the averaged signal acquired from an area of 1 cm² and the amplitude threshold has been experimentally determined by comparison with the calibration sample.

In order to automate the measurement process, the rotary motion with a step motor has been applied for the pipe immersed in water. This movement has been kinematically coupled with the ultrasonic probe displacement along its axis. The acoustic beam axis swept a helical curve on the pipe surface. The helical pitch has been adjusted to approximately 10 mm. The perpendicular position of the ultrasonic probe and the fixed distance of 10 mm from the pipe surface work as time delay for the signal and give also the required acoustic coupling. Moreover, the distance between the successive peripheral measurements has been set to 10 mm, which ensures that all the examined area will be covered for the assumed ultrasonic beam width.

Measuring equipment and software

The need for automating the measuring process, including analysis of the ultrasonic signal, recording, visualization of the results and control of the ultrasonic

probe displacement prompted the authors to use a PC and the Windows® operating system as the basis for the control/measuring bus for the whole equipment.

Fast access to ultrasonic signals can be assured only by specialized extension PC cards so they were used for the experiments instead of separate digital devices operating via much slower external interfaces available. The SFT4001C ultrasonic pulser-receiver PC card and STF4200 analogue-to-digital converter were used, both being products of SOFRATEST, France. These cards, operating on the ISA data bus, may be internally synchronized with the clock signal coming from the pulser-receiver PC card and their optimum cooperation occurs at a frequency of 80 MHz.

The software is able to realize the function of a typical ultrasonic flaw detector with the screen resolution of 512 x 256 pixels, two hardware gates (monitors located on PC cards) and two software gates, system for data saving on hard disks and data browsing. All the settings of the transmitter-receiver parameters, analogue-digital converter and monitoring system can be stored in a disk file and retrieved at any moment [4].

The stand is equipped with a stepping motor power supply. The motor is controlled by the computer. Limit switches are also installed enabling the probe positioning at the start point and ensuring the automatic switch off after the measurement completion. The layout of the experimental setup is presented in Fig. 3.

The probe displacement above the surface of the examined pipe segment takes place along the helical curve – it is a result of the superposition of the rotary movement executed by the stepping motor and longitudinal motion being a result of rolling the rubber roll along the examined surface. The axis of rolling and the axis of the examined object are at an angle equal to the helical lead angle.

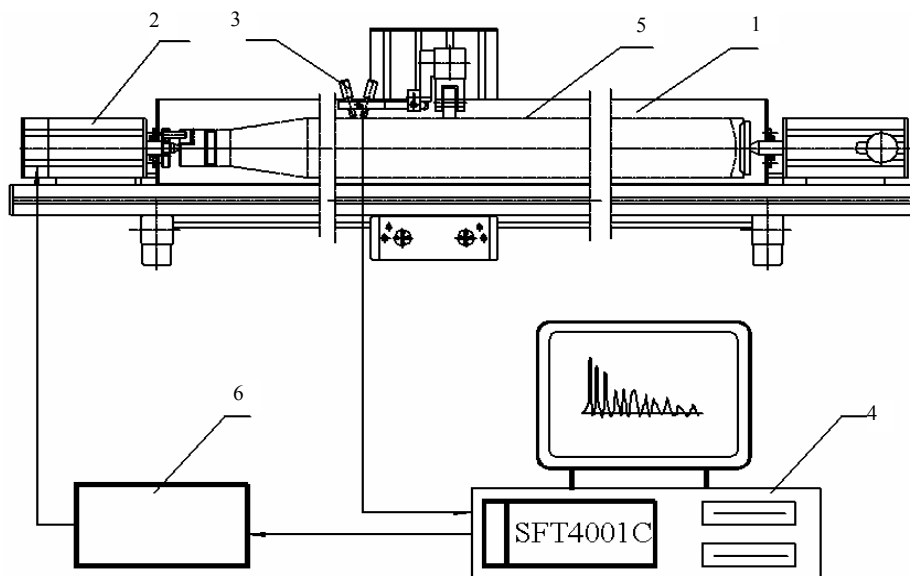

Fig. 3. Setup of the experimental stand, 1- operating tank, 2 – driving system, 3 – ultrasonic probe, 4 – computer equipped with software for the control functions, 5 – examined object, 6 – stepping motor controller

Methodology of experimental investigations

Requirements imposed by the designer on adhesive joints can be typically defined by specifying the percent share of the unglued area to the total joint area. The area of the maximum unglued surface or relative locations of the unglued places can also be given. The graphical presentation accounts for an additional factor, which is needed for estimating the correctness of the joint.

The developed methodology of ultrasonic tests including measurement automation and the applied experimental setup together with the computer system for data acquisition including the elaborated software makes it possible to render an accurate estimation of the examined joint quality. The complete measuring system is presented in Fig. 4.



Fig. 4. Photograph of the measuring system during the experiments

Areas have been detected where there was no adhesive joining between the composite and the metal surface. The phenomenon of damping the ultrasonic signal reflected from the glued layer of the thermal insulation has been employed for the proposed measurement method. The ultrasonic signal is transmitted and received by the ultrasonic probe using the echo technique [1, 6].

The area of the measuring gate encloses the measuring place. Each input signal which, exceeds the threshold level, which was assumed as 25% of the display window height (threshold in the measuring gate), is registered by the software as the unglued thermal insulation.

Individual signals registered while the signal threshold crossings are noted as colored fields on the graphical computer image.

These signals are additionally registered and processed by the computer program as the percent share of the unglued area.

The oscilloscope representation of the ultrasonic signal appearing in one of the windows on the computer screen for properly glued thermal insulation is presented in Fig. 5a. The ultrasonic signal image for the place of the unglued thermal insulation is presented in Fig. 5b.

For automating the inspection of the gluing quality, additional options offering a simpler use of the equipment have been applied. Selecting them from the available menus reduces the amount of on-screen information to one window with graphical presentation of the examination

results and one monitoring window sized at 128 x 128 pixels, showing the threshold level and the selected fragment of the ultrasonic signal after detection (full wave rectification). Examination process can be started or interrupted by pressing "Space" key on a computers keyboard and it stops automatically after completion.

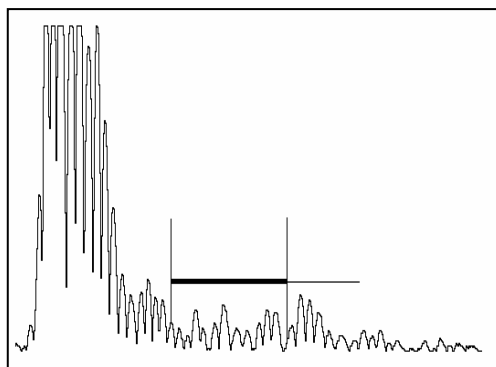

a

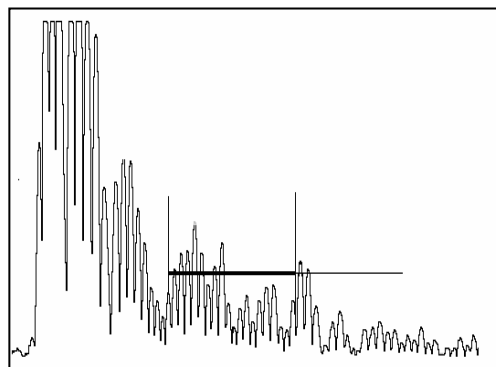

b

Fig. 5. Typical oscilloscope representation of the ultrasonic signal in place of a) properly glued thermal insulation, b) unglued thermal insulation

Increase of the ultrasonic signal over the threshold level in the selected time range (visible in the monitoring window) is denoted by the red color.

The relevant data file includes the current date and number of successive measurements made on the given day, extra information on the compact measurement results (flawed area in cm² and the percent share), current gain factor of the receiver and the file name containing full results.

The stepping motor control is made via the computer parallel port and the emergency stop interrupting the measurement can be executed by the limit switch on the drive system. The limit switches are connected to the computer via the computer game port. The set of control parameters of the mechanical movement can be changed only by editing the program initializing file. The most sensitive parameter – the receiver gain (which is set during the calibration process) is every time recorded along with the measurement results.

Inspection of the gluing quality of the rocket engine combustion chamber

The experiments were aimed at inspecting the quality of the gluing joint between the steel casing and the thermal

insulation layer. The relevant detailed requirements are normally specified in the available technical documentation attached to each inspected product.

The combustion chamber of a sustained rocket engine of the thrust of 15 kN was considered as a typical object of the examination.

Requirements imposed by the designer on the adhesive joints can be typically defined by specifying the percent share of the unglued area to the total joint area. The area of maximum unglued surface or relative locations of the unglued places can also be given. The examples of not glued locations (flaws) were given in Fig. 6a.

The map of the examined surface [8] is a detailed result of the inspection and it is obtained during the surface scanning process. A typical image is shown in Fig. 6b – there are visible areas where the gluing of the thermal insulation and the metal is not satisfactory. There are digital data printed below, concerning the flawed zones: their total surface and their percent share to the total chamber surface.

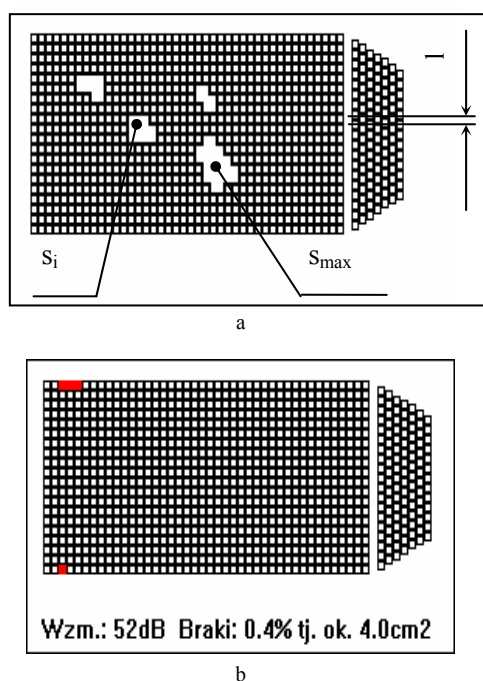

Fig. 6. Typical distribution of not glued areas (faults) in the inspected product (a), typical image presenting of the test result (b)

Each representation of the results in the map form can be analyzed in view of the requirements stated by the designer.

Conclusions

1. The ultrasonic measurements of layered composites should be preceded by a selection of ultrasonic probes of adequate characteristics and operating frequency.
2. Possibility of employing the ultrasonic signals for estimating the quality of the adhesive layered joints has been explored in this work.
3. Proper determination of the time gate duration for the investigated signals and their time delay relative to the initial instant for the pulse reflected from the steel pipe surface makes it possible to use such signals for estimating the ultrasonic wave damping characteristics

and, consequently, for estimating the glued joint condition.

4. Analysis of the performed investigations shows that if one aims at obtaining reliable results it is necessary to define precisely the area of the measurement and properly select the distance between the probe and the examined surface; these measurement parameters should be preset during calibration sample testing.
5. Effective assessment of the glue joints implies their possible applications in highly reliable products and makes it possible to estimate the quality of the adhesive joints directly on the manufacturing line and it can be helpful in immediate recognizing of the reasons for the flaws occurrence and their avoiding by manufacturing process modification.
6. The applied method is well fitted for storing of the measurement results as computer files which is in many cases imposed by the elaborate a procedures.

Reference

1. **Alyeszyn A. P. et al.** Methods of ultrasonic flaw detection in materials. Machine building. Moscow. 1989. (in Russian).
2. **Calikowski R., Oleksiak Z., Pytko S., Skorupa A.** The ultrasonic flaw diagnosing of friction joints. Ed. PWN. Warsaw. 1989. (in Polish).
3. **Cisłowski W., Mottl Z.** Short-pulse broadband ultrasonic transducer. Proceed. of the XIVth Conference Non-destructive Testing, R-9, Kiekrz, Poland. 1985. (in Polish).
4. **Gutkiewicz P., Spadło S.** Computer measurement system for inspecting the quality of thin-walled metal-composite joints by ultrasonic flaw detection method. Proceed. of the 3th Scientific Conference. Precision Targetting Ammunition, Execution, Protection and Power Supply Systems. Ameliówka, Poland. 2000. (in Polish).
5. **Obraz J.** Ultrasound measurement techniques. WNT, Warsaw. 1983. (in Polish).
6. **Pawłowski Z.** Non-destructive testing. Handbook. Ed. SIMP. Warsaw. 1984. (in Polish).
7. **Pilarski A., Marciniak B.** The ultrasonic flaw detection method for evaluating shear strength of laminates. Proceed. of the VIIth Conference Non-destructive Testing, K-10, Uniejów, Poland. 1977. (in Polish).
8. **Spadło S., Gutkiewicz P.** Computer system for evaluating adhesive joints in laminate composites by ultrasonic flaw detection method. Transactions of the Kielce University of Technology (KUT). Kielce, Poland. 2004. Vol. 80. P. 431-438. (in Polish).
9. **Teti R., Alberti N.** Ultrasonic identification and measurement of defects in composite material laminates. Ann. CIRP, 39/1/1990. P. 527-530.

S. Spadło

Klijuotų įrenginių sluoksnių sujunginių ultragarsinė diagnostika ir gedimų ieška

Reziumė

Rakietinių variklių plonasienių elementų naudojamos formos korpusai, skydai ir aviacijos technologijos turėtų būti parengtos veikti esant didelėms mechaninėms apkrovoms. Daugeliu atvejų eksploatacija priežiūra ir sauga yra artimai susijusios su šių elementų patikimumu. Konstrukcijos dažnai patiria papildomą šilumos poveikį ir cheminį poveikį, vyksta erozija ir paviršių aptekėjimas, todėl apsauga yra būtina. Bet apžiūrėti bendrą klijų kokybę beveik neįmanoma. Iki šiol dalys buvo tikrinamos rankiniu būdu - ultragarsiniu zondų išilgai paviršiaus. Specialios įrangos trūkumas sukelia sunkumų, susijusių su ultragarsinio zondavimo tikslumu. Straipsnyje pateiktas kompiuterio matavimo išdėstymas ir komponentų konfigūracijos, naudojamos patikrinti plonasienių metalų diuritų su sluoksniškais kompozitais prisiklijavimui prie korpuso. Sistema leidžia ne tik įvertinti, registruoti ir analizuoti ultragarso signalą, bet ir pateikti grafinio tyrimo rezultatus. Naudojant specialius plačiajuosčius zondus, kurie siunčia labai trumpą (0,2 μs) impulsą, buvo galima stebėti ir išilginės bangos įtaką, ir nustatyti kokybę.

Received: 3 06 2009

DOI: 10.5755/j01.u.64.2.17100