

Investigation of correlation in bearings' vibrations of high-performance centrifugal pumps

V. Volkovas, A. Perednis

Kaunas University of Technology, Technological System Diagnostic Institute,

Kęstučio str. 27, 44312 Kaunas, Lithuania,

E-mail: vitalijus.volkovas@ktu.lt

E-mail: arunas.perednis@gmail.com

Abstract.

The article analyzes the reasons of increase in vibrations of four equal high-performance centrifugal pumps and their correlations in case of different working rotations. The influence of rigidity of bearings' housing and rotors on the values of vibrations is analyzed. The results of the investigation on correlation in bearings' vibrations of one of these pumps done earlier were used to check the objectivity in other pumps. The change in the correlations of vibrations is explained by different dynamic models in two characteristic ranges of working rotations. The uncertainty of the data measurement of these tests was analyzed and it was shown that the total uncertainty does not have essential impact on the values of vibrations and their changes used in the correlation investigation.

Keywords: pump, bearing, dynamical behavior, mathematical model, vibration analysis, data correlation, diagnostics

1. Introduction

The rotating systems form quite a wide class of mechanical systems that is applied in a very versatile mode and that has become an integral part of any machine and most of mechanisms. The big dynamic load of rotating systems is determined by the growth of speed, while the requirements of high reliability and durability have directly affected the constructional elements of the systems. The control of rotating systems is becoming deeper and deeper, and the diagnostics of technical condition is directed to separate units and elements. Insufficient depth of diagnostics (possibility to detect faults in the hierarchy of the elements of mechanical system) did not allow diagnosing the appearing faults on the level of elements, and when they appear in the system, usually it is already impossible to avoid serious consequences of accidents. It could be mentioned as an example that the faults of the elements of pumps (bearings, torque collars, working wheels and shafts) in "Mažeikių nafta" Ltd. in 1986-1996 resulted in big losses, when fire was destroying all technological lines [1]. The accident that happened on August 17, 2009 in Russia, in Sayan-Shushensk hydroelectric station is regarded as the technogenic catastrophe that was caused by insufficient control of the elements of turbines and disregard of their degradation [2]. The reliability and durability of engineering assets, repair possibilities and control means (including diagnostic means) have a direct influence on the safe exploitation [3].

Rotating systems of energetic objects are turbines, generators and high-performance pumps, which are characterized by dynamic processes. They require increased attention for technical condition, its identification and control. The dynamics of rotating systems and diagnostics of faults is the area of mechanical systems that is being actively investigated, but despite numerous monographs and published investigations on dynamics and diagnostics of the systems, they remain

unsolved. The development of rotating systems, new constructions, materials and functions raise new questions not only in the meaning of methods and tools, but also the conceptual questions.

Among the variety of diagnostic methods of rotating systems, the vibroacoustic methods are distinguished by their high universality and wide application in practice [4]. However, the distribution of the parameters of rotating systems, peculiarities of constructions, difficulties of the mathematical model of its dynamics in the case of fault, uncertainty of the fault's analysis when the location and amount are unknown and the non-homologous influence of the fault on the stability of the entire construction stimulate the further development of vibrodiagnostic methods and analysis of the systems the vibrations in various aspects.

The work [5] has analyzed the high performance centrifugal supply pump of the steam turbine CBПЭ-320-550 JIM3. The main problem of this supply pump is the enlarged vibrations of the bearings (they exceed the mean norm of the vibration speed significantly – 7,1 mm/s) and the characteristic thrust of the dimensions on the rotor's rotation. The data of the monitoring system of pumps were used to analyze the correlation between the vibrations of bearings of the pump's rotor and different components of the measured vibration spectrum. It was determined that the vibration speed of the bearings of the pump's rotor in the horizontal direction can be characterized by a high correlation value when the rotation increases. Also the sign of the correlation coefficients of the components of individual spectrum changes at the same time and this could outline the energy distribution of the processes for the account of the influence of superharmonics on vibration values.

We try to collect data in this work, which would confirm this hypothesis and explain the phenomenon of vibration changes and reveal their reason, following the models of vibrations.

2. Monitoring data of supply pumps and fault analysis

The investigated objects are four high-performance centrifugal supply pumps of the steam turbine EMS 5-8,

type CBПЭ-320-550 JIM3 (see Fig. 1). Each pump consists of electric motor, hydro-socket, reducer and multistage pump (its section is presented in Fig. 2).

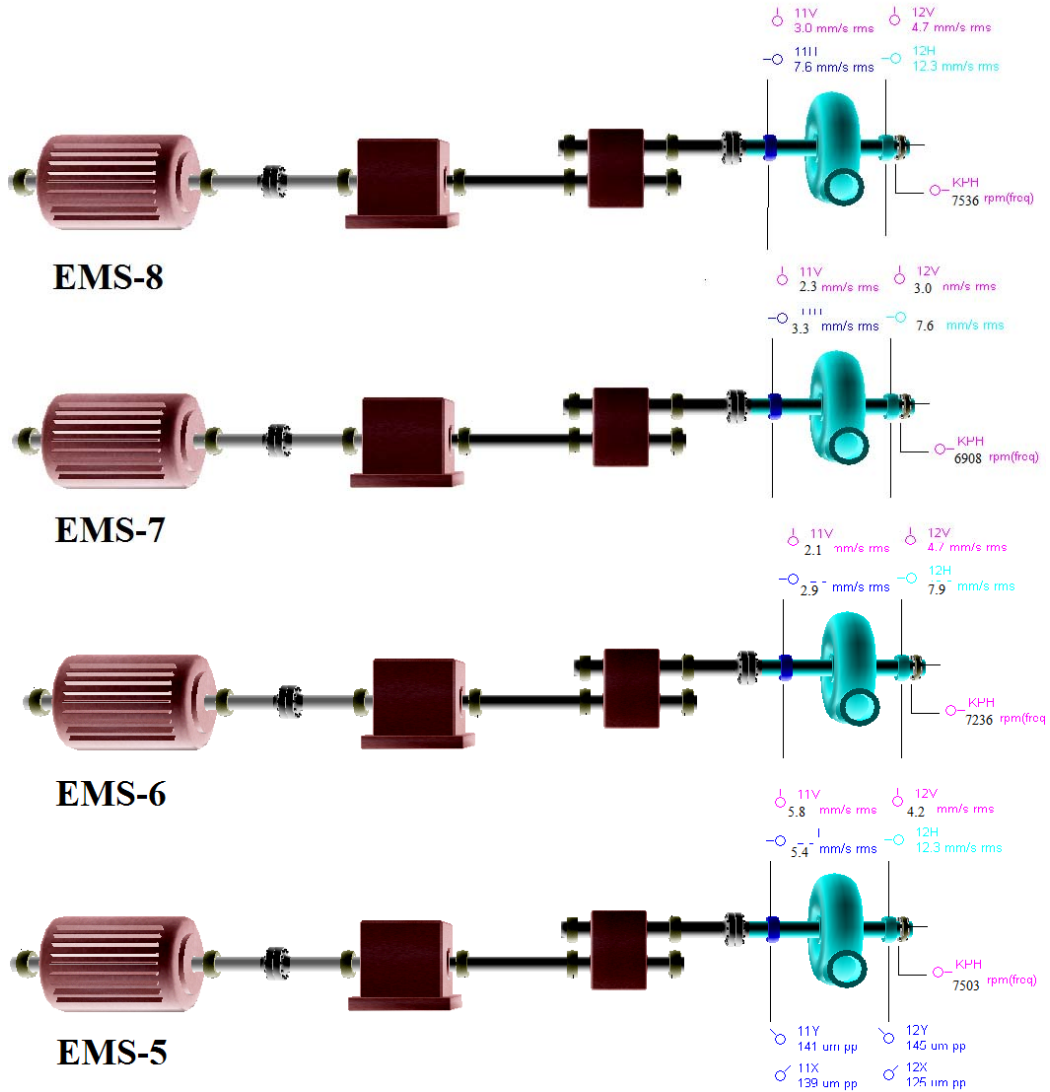

Fig 1. Investigated high-performance centrifugal pumps and vibration monitoring data of their 11 or 12 bearings in different observation time

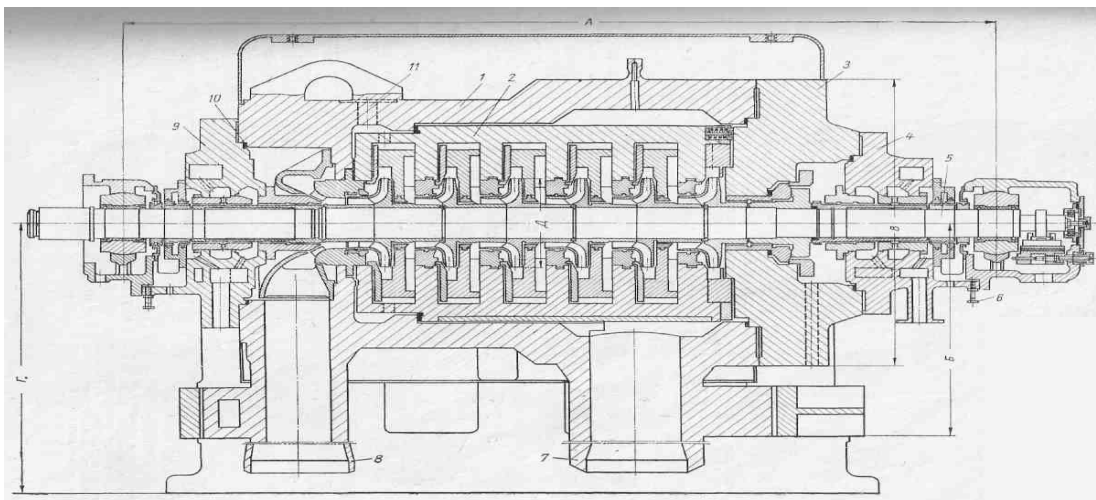

Fig. 2. Section of centrifugal pump: 11 bearings on the left, 12 – on the right

Table 1. Components of the vibration spectra of 11 and 12 bearings of centrifugal pumps in the horizontal (H) and vertical (V) directions

	11 V, mm/s	11 H, mm/s	12 V, mm/s	12 H, mm/s	f_1 Hz	f_2 Hz	f_7 Hz	r.p.m.
EMS-8	0,7-(31Hz) 0,5-(125Hz) 0,7-(543Hz)	6,3-(125Hz) 1,8-(173Hz) 0,5-(251Hz)	4,1-(125Hz) 2,1-(181Hz) 2,4-(881Hz)	3,3-(125Hz) 2,9-(173Hz) 4,0-(251Hz)	125	251	875	7500
EMS-8	0,3-(206Hz) 0,9-(245Hz) 1,5-(724Hz)	0,8-(38Hz) 1,9-(103Hz) 0,7-(206Hz)	1,3-(51Hz) 1,9-(103Hz) 2,7-(724Hz)	5,6-(103Hz) 2,5-(206Hz) 0,7-(245Hz) 1,0-(724Hz)	103	206	721	6186
EMS-7	0,8-(51Hz) 0,9-(116Hz) 2,5-(818Hz)	6,9-(116Hz) 1,0-(175Hz) 1,9-(233Hz)	1,4-(51Hz) 1,3-(430Hz) 2,6-(818Hz)	2,8-(116Hz) 2,1-(175Hz) 7,6-(233Hz)	116	233	812	6960
EMS-7	0,5-(53Hz) 1,8-(107Hz) 1,1-(749Hz)	0,6-(46Hz) 2,9-(107Hz) 0,9-(214Hz)	4,1-(107Hz) 2,1-(181Hz) 2,4-(881Hz)	5,6-(107Hz) 1,6-(125Hz) 1,2-(749Hz)	107	214	749	6421
EMS-6	1,7-(115Hz) 0,9-(159Hz) 1,2-(810Hz)	No measurement	2,0-(115Hz) 0,7-(144Hz) 1,4-(810Hz)	No measurement	115	230	805	6949
EMS-6	1,2-(51Hz) 1,0-(102Hz) 0,9-(714Hz)	No measurement	1,4-(38Hz) 1,2-(51Hz) 2,9-(714Hz)	No measurement	102	204	714	6152
EMS-5	3,4-(124Hz) 1,9-(374Hz) 1,5-(623Hz)	15-(124Hz) 6,0-(253Hz) 1,6-(888Hz)	1,1-(46Hz) 3,0-(124Hz) 2,8-(873Hz)	5,8-(124Hz) 2,6-(252Hz) 2,9-(882Hz)	124	248	868	7440
EMS-5	1,1-(51Hz) 1,3-(103Hz) 3,1-(721Hz)	3,5-(103Hz) 1,9-(186Hz) 6,5-(206Hz)	2,0-(103Hz) 0,8-(206Hz) 4,5-(721Hz)	14-(103Hz) 3,9-(206Hz) 8,1-(721Hz)	103	206	721	6184

Remark: data in bold are from the work [5].

The instruments provided by vibration monitoring system allowed analyzing the orbits of bearing motion and vibration spectra, and “waterfall” diagrams (see Figs. 3 and 4). However the analysis’ results did not allow determination the reasons of the specific behavior of the 11 and 12 bearings in transient modes, i.e. to make diagnosis of the pump state unambiguously. Therefore, we shall use the earlier investigations in order to determine the reasons of increased vibrations of all four pumps when the working rotations of the pump are changing.

The data recorded in one year period by the monitoring system “Bently Nevada 3500” [4] were used as measurement data for an additional correlation analysis, aim of which was to determine dependences: pump rotation – 11H vibrations, pump rotation – 12 H vibrations, 11H vibrations – 12 H vibrations, correlation between these bearing vibration spectrum components and also to assess quantitatively the relation between symptoms and diagnosis and to explain the dynamical behavior of the pump in transient modes (see Table 1).

Working with minimum pump (EMS-5) load, when the pump rotation is about 6200 r.p.m., the 12H bearing vibration (H – in the horizontal direction) increases to 14mm/s, while 11H at the same time decreases down to 3,5 mm/s. The vibration values at these rotations are stable, but when the pump is loaded maximally and rotation reaches 7500 r.p.m. – 12H decreases down to 5,8 mm/s, and 11H increases to 15 mm/s. This is evident in the table when the vibration measurement data f_1 (f_1 is the first harmonic of working rotations) is compared in case of minimal and maximum rotation (Table 1). Such growing tendencies of vibrations are seen in all the pumps, except EMS-6 that does not have any vibration measurements of 11H and 12H bearings.

When the vibration measurement data f_2 (f_2 is the second harmonic of working rotations) are compared in Table 1, the component is not big and makes 1/3 or smaller part of the absolute vibration.

Table 1 also distinguishes separately f_7 (f_7 is the seventh harmonic of working rotations). This is working

vibration of the pump's vanes that is not very big, except for the vibration of EMS-5 12H bearing, where it makes 1/2 part of the absolute vibration. These vibration tendencies could be seen in "waterfall" diagrams (see Fig. 3 and 4).

The dynamical behavior of pump's bearings in transient modes did not allow determining completely the

reasons for increase and decrease of vibrations, thus the additional correlation analysis of measurement data was performed and the natural frequencies of bearings were measured using the method of mechanical impedance.

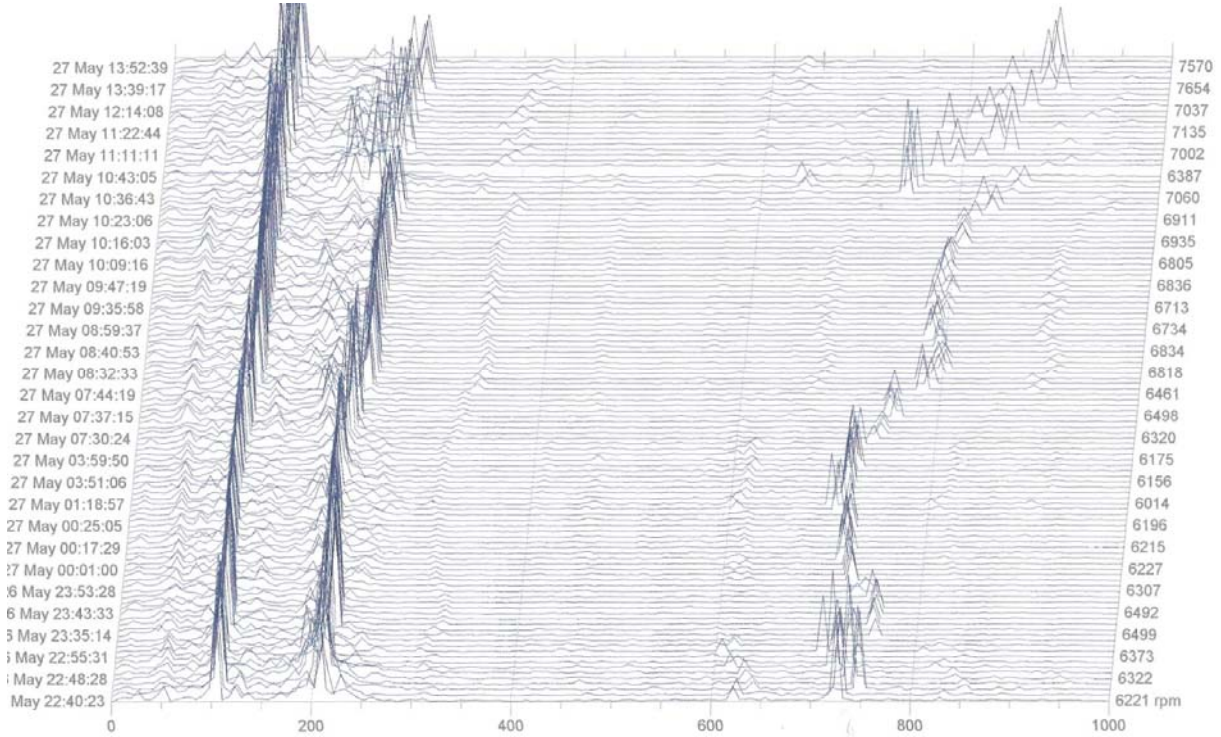

Fig. 3. Waterfall diagram of 12H bearing of EMS-5 pump, when the working rotations change during operation

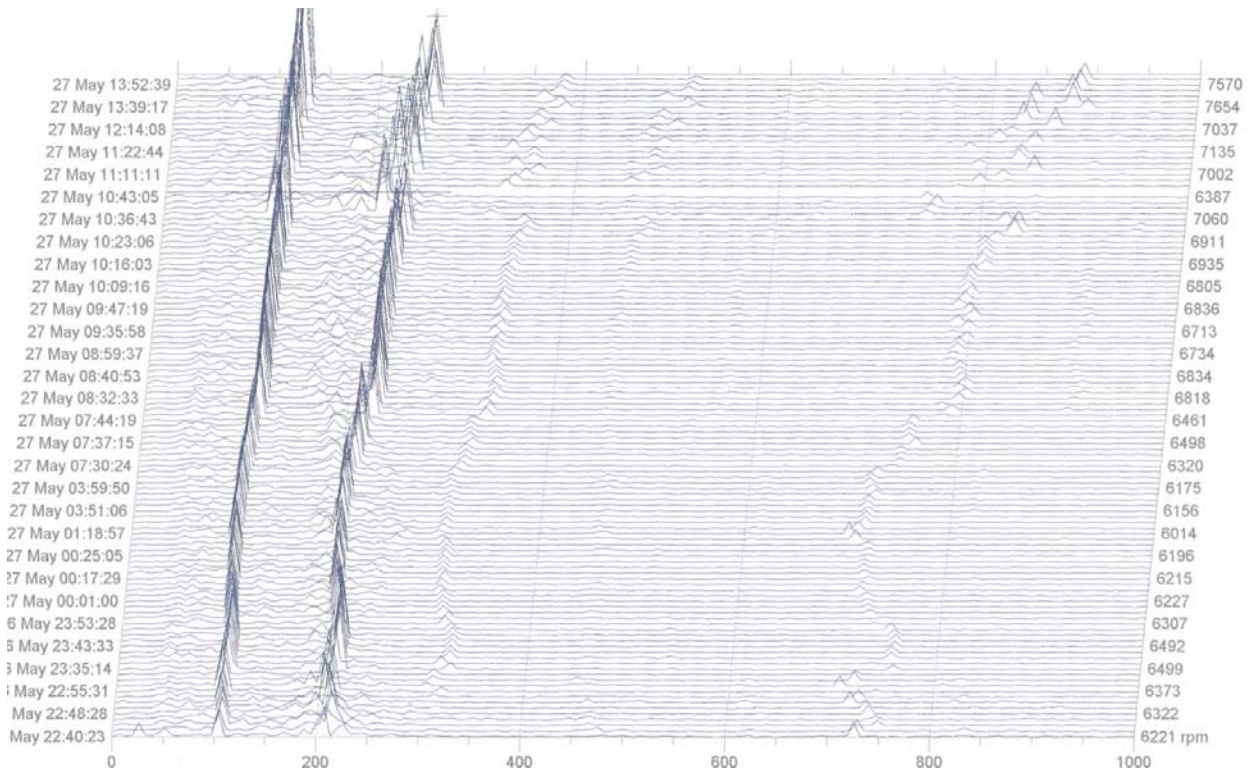

Fig. 4. Waterfall diagram of 11H bearing of EMS-5 pump, when the working rotations change during operation

3. Investigation of pump's natural frequencies

The natural frequencies of the fastening of supply pump's bearings and pump base were investigated in experimental way using a pulse method by exciting

vibration in horizontal (H) and vertical (V) directions [5]. The biggest response was received while exciting in the horizontal direction.

Fig. 5 provides frequency responses of the all analyzed support elements of pumps' bearings and base.

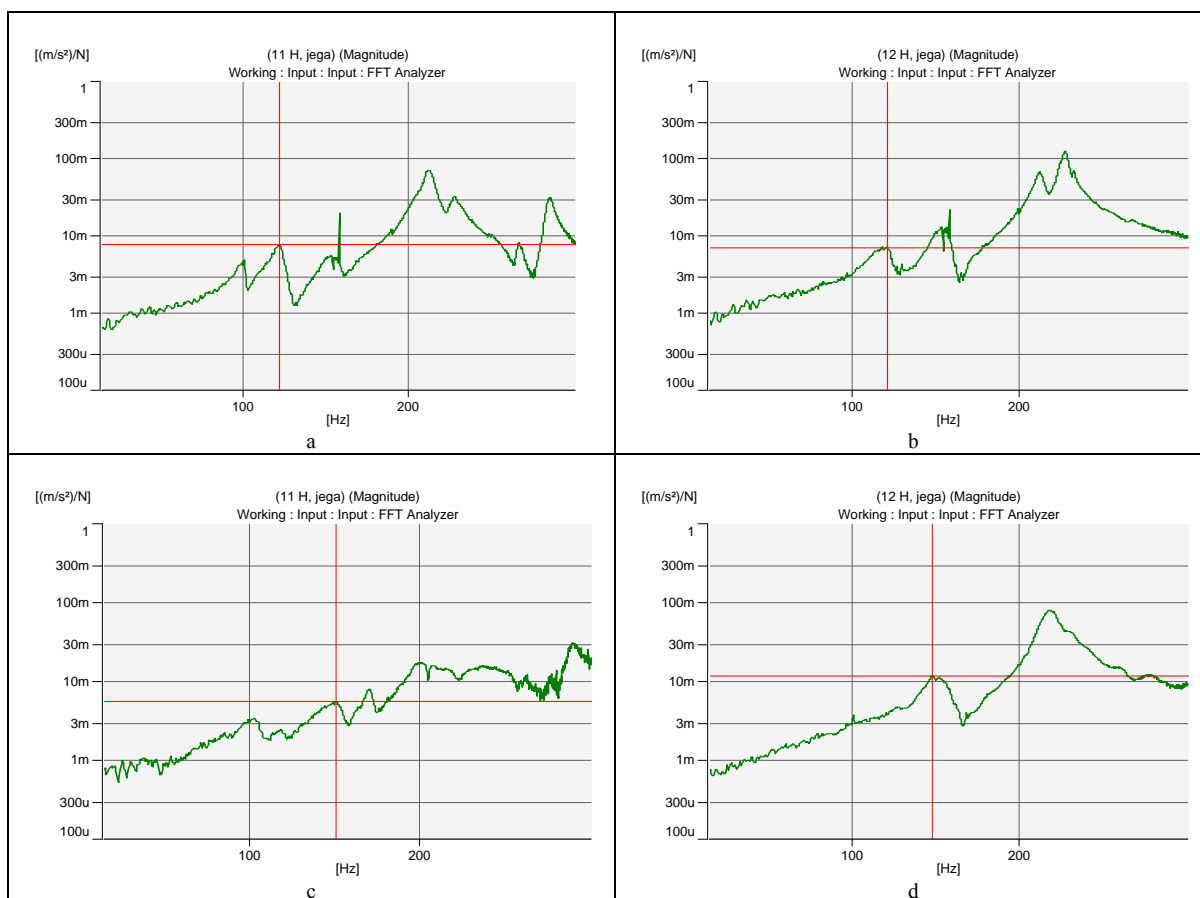

Fig. 5. Frequency responses of centrifugal pump bearings: a - EMS-5 – frequency response of 11 bearing vibration in the horizontal direction when excitation is performed in horizontal direction beside 11 bearing; b - EMS-5 – 12 frequency response of bearing vibration in horizontal direction when excitation is performed horizontally beside 12 bearing; c - EMS-6 – vibration in horizontal direction of bearing's base when excitation is performed beside 11 pump base; d - EMS-6 – 12 bearing vibration in vertical direction when excitation is performed vertically beside 12 bearing

The analysis of natural frequencies shows that vibrations of 11 and 12 bearings of all the pumps in the horizontal direction are different according to the resonance frequencies and amplifications. This is the reason of above indicated specific vibration states and behaviors (when the rotation increases and decreases). It should be noted that the peak of the 11 H frequency response at the 106 Hz value might be the outcome of the pump base natural frequency. The frequency responses of 12 H bearing are close to 128 Hz. It could be said that one of the problems of these pumps is that the natural frequency of the housing of pump bearings is very close to the pump rotor's first harmonic. This could also be seen in the "waterfall" diagrams (see Figs. 3 and 4) – it is seen how with the changing working rotation, the f_1 harmonic of 11 bearing increases and that of 12 bearing decreases, or on the contrary, that of 11 decreases and of 12 bearing increases. This could be related to the coincidence of natural frequency of the housings of bearings and rotation speed.

4. Uncertainty analysis of vibration measurements and its influence on monitoring data

Each measurement result has a measurement uncertainty, thus the quality evaluation of measurement data also affects the uncertainty of our vibration analysis and conclusions [6]. The measurement uncertainty in the present vibration monitoring system consists of three main components: the component of environmental impact, the instrumental component (calibration uncertainty, instrument's location with regard to the object) and the component of time (because vibration is temporary characteristic). This component of time requires to take into consideration past data when the uncertainty is assessed [7]. This article has been analyzing similar uncertainty of the time component of a rotating system and following this it is possible to state that the measurement uncertainty does not have a big influence on the obtained results.

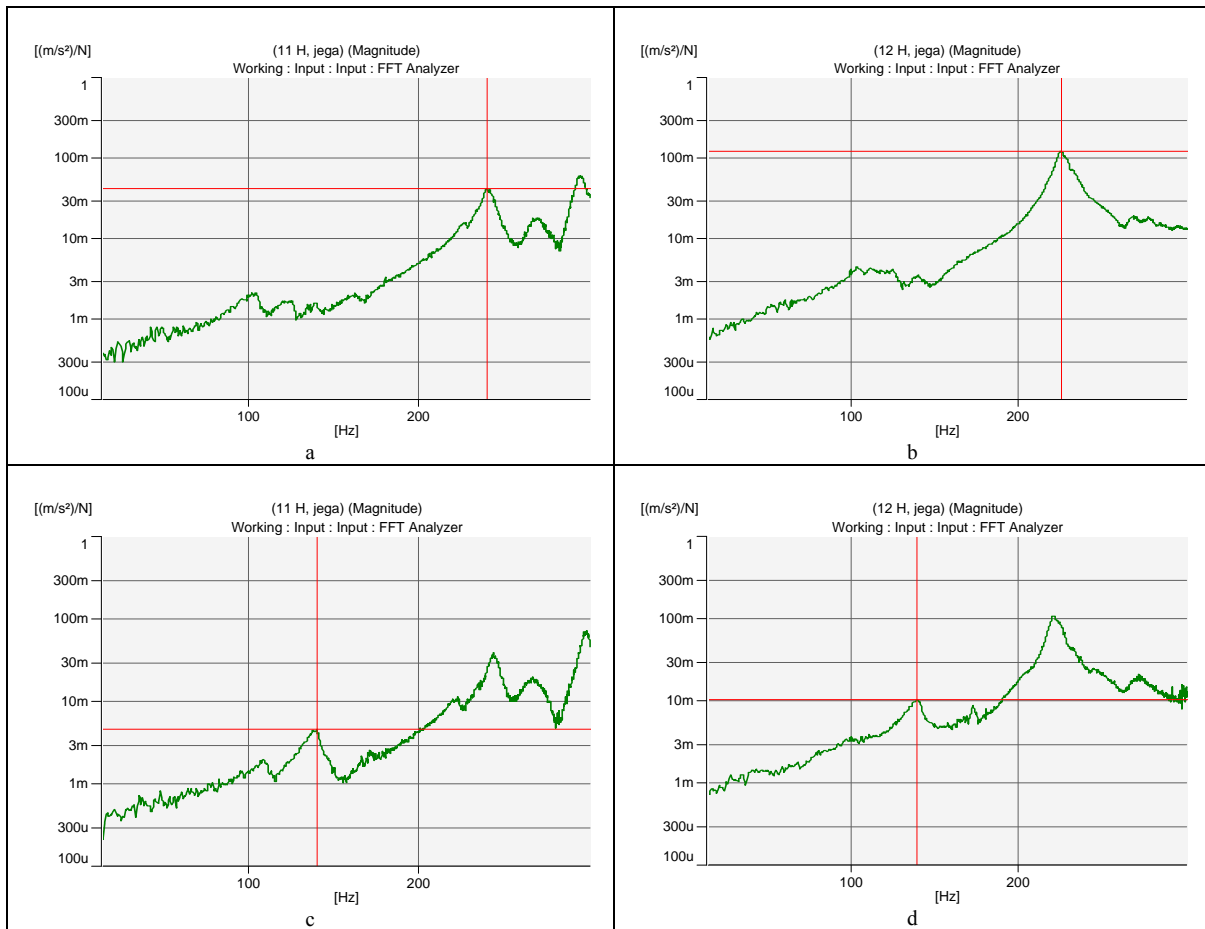

Fig. 6. Frequency responses of centrifugal pump bearings: a - EMS-7 – frequency response of 11 bearing vibration in horizontal direction when excitation is performed in horizontal direction beside 11 bearing; b - EMS-7 – 12 frequency response of bearing vibration in horizontal direction when excitation is performed horizontally beside 12 bearing; c - EMS-8 – vibration in horizontal direction of bearing’s base when excitation is performed beside 11 pump base; d - EMS-8 – 12 bearing vibration in vertical direction when excitation is performed vertically beside 12 bearing

5. Dynamical and mathematical models of pumps’ vibrations

According to the investigation, when the rotation of pump’s rotor changes, the natural frequencies of the bearing bases and rotor’s dynamical characteristics affect the vibration values. In case of a high vibration correlation, the rotor may be analyzed as a solid body,

while the pump’s dynamical model could be simplified as it is shown in Fig. 7.

We shall analyze the simplified model of the pump and we shall consider it a rigid beam on elastic supports. The dynamic model of the pump is a uniform rigid beam supported at the ends with linear springs of stiffness k_1 and k_2 and viscous dampers c_1 and c_2 at the points A and B respectively.

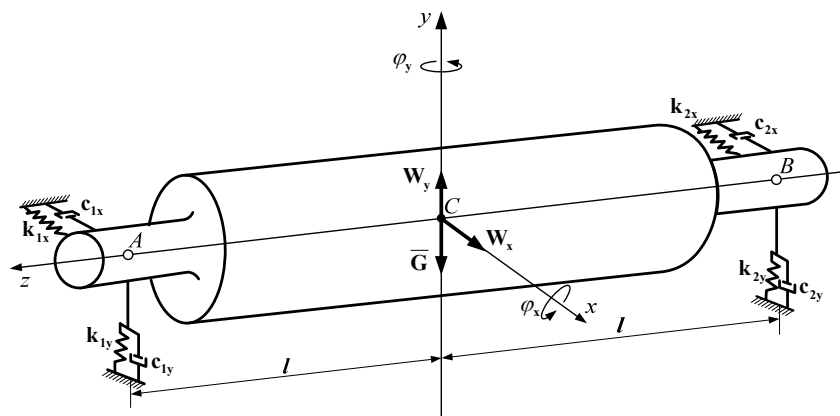

Fig. 7. Dynamical model of centrifugal pump

For the correlation investigation of vibrations at the point *A* (bearing of pump 11) and the point *B* (bearing of pump 12) we shall consider them independent in the directions *x* and *y*. Then the equation of motion in the *y* direction shall be:

$$\mathbf{M}\ddot{\mathbf{w}} + \mathbf{C}\dot{\mathbf{w}} + \mathbf{K}\mathbf{w} = 0 \quad (1)$$

where $\mathbf{w} = \{w_y, \varphi_x\}^T$ is the displacement vector, w_y – in the *y* direction and φ_x the small angles about *x* axis; $\mathbf{M} = \text{diag}[m, I]$, the mass matrix; m is the mass, and I the mass moment of inertia about the mass center of the beam;

$\mathbf{K} = \begin{bmatrix} k_1 + k_2 & -k_1l + k_2l \\ -k_1l + k_2l & k_1l^2 + k_2l^2 \end{bmatrix} = [k_{ij}]$, stiffness influence coefficient matrix;

$\mathbf{C} = \begin{bmatrix} c_1 + c_2 & -c_1l + c_2l \\ c_2l - c_1l & c_1l^2 + c_2l^2 \end{bmatrix} = [c_{ij}]$, damping influence coefficient matrix.

The equation of motion in the *x* direction could be written in the analogous mode.

These equations led to determination of natural frequencies from an algebraic equation

$$\begin{vmatrix} -\omega^2 m + k_1 + k_2 & -k_1l + k_2l \\ -k_1l + k_2l & -\omega^2 I + k_1l^2 + k_2l^2 \end{vmatrix} = 0 \quad (2)$$

The system's natural frequency ω_i is subject to stiffness k_1 and k_2 for constant m, l and I .

When rotation increases, the resonances of separate pump's discs is manifested (this is seen in the Fig. 3, 4 and Table 1). It could be presumed that superharmonics are excited by various discs, which change the rotation of vibration components by 7000 r.p.m. In this case the rotor shall be considered as a flexible shaft with several masses (see Fig. 8).

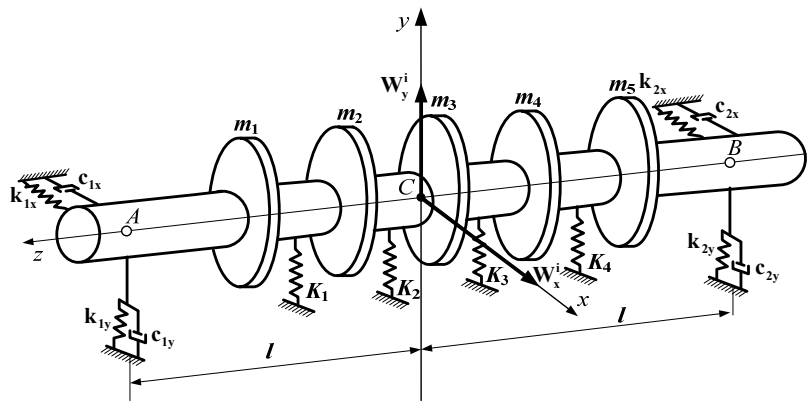

Fig. 8. Dynamical model of centrifugal pump with discs

There the dynamical model could be expressed by five discs arranged on the shaft symmetrically with masses m_i and stiffness K_i (see Fig. 8). It is five-degree-of-freedom

system. Applying the Newton's law we obtain the equations of motion and then frequency equation:

$$\begin{vmatrix} -m_1\omega^2 + k_1 + K_1 & -K_1 & 0 & 0 & 0 \\ -K_1 & -m_2\omega^2 + K_1 + K_2 & -K_2 & 0 & 0 \\ 0 & -K_2 & -m_3\omega^2 + K_2 + K_3 & -K_3 & 0 \\ 0 & 0 & -K_3 & -m_4\omega^2 + K_3 + K_4 & -K_4 \\ 0 & 0 & 0 & -K_4 & -m_5\omega^2 + K_4 + k_2 \end{vmatrix} = 0 \quad (3)$$

Following the analysis of the Eq.2 and 3, we see that the natural frequencies in the second case depend on m_i and K_i . As $m_i < m$, it is possible to state that the second model shall have more resonances at high frequencies. Therefore when the pump's rotation increases, the energetic redistribution of vibration components takes place, and this affects decrease of processes' correlation and appearance of super resonances. Of course, we have used simplified models, which do not show the full view of dynamics, but they are sufficient to explain the changes of vibrations of pump bearings related to the debit's regulation while changing the pump's rotation.

6. Conclusions

1. The analysis of monitoring system data – vibration time-wise change curves, orbits and bearing vibration spectra might be insufficient to explain dynamical behavior of the system and to make conclusions about the state of rotating system.
2. The data correlation analysis supplements the instruments of monitoring system and extends their informative scope. This can be especially effective in transient modes of a rotating system.
3. When rotation of a rotating system (centrifugal pumps) changes, the small differences of natural

frequencies of the bearing fastening elements and their overlaid frequency responses with different amplification features beside natural frequencies may be the reasons of inverse vibroactivity of the rotor bearings and then the vibration of those bearing exceed permissible limit.

4. The total measurement uncertainty of a stationary monitoring system of vibration measurements is very small and does not have an essential influence on the vibration values and their changes used in the investigation of correlations.
5. The earlier investigation results on a vibration correlation of one of the pumps were used to check the objectivity in other pumps. The change in the correlations of vibrations is explained by different dynamic models in two characteristic sectors of working rotations.

References

1. **Jonušas R., Jurkauskas A., Volkovas V.** Rotorinių sistemų dinamika ir diagnostika. ISBN 9986-13-898-1. Monografija. Kauno technologijos universitetas. Kaunas: Technologija. 2001. P.295.
2. http://www.infox.ru/accident/incident/2009/09/11/SP_tri_goda_naza_d_pr.phtml
3. **Volkovas V.** Development and application of vibroacoustic diagnostics and condition monitoring methods in Lithuania. *Insight*. 2001. Vol. 43. No. 6. P.376—380.
4. **Bently D., Hatch C., Grissom B.** Fundamentals of rotating machinery diagnostics. Bently Pressurized Bearing Press. 2002. P.723.
5. **Volkovas V., Eidukevičiūtė M., Perednis A.** Investigation of correlation in centrifugal pumps monitoring data. *Vibroengineering* 2008. Proceedings of 7th International Conference. October 9-11, 2008, Kaunas University of Technology, Lithuanian Academy of Science, IFTOMM National Committee of Lithuania. - ISSN 1822-1262. Kaunas. 2008. P. 6 -10.
6. **Eidukevičiūtė M., Volkovas V.** Measurement uncertainty in vibromonitoring systems and diagnostics reliability evaluation. *Journal of Sound and Vibration*. ISSN 0022-460X. 2007. Vol. 308. Iss. 3-5. P. 625-631. Internet access: <<http://www.sciencedirect.com/science/journal/0022460X>>.
7. **Eidukevičiūtė M., Volkovas V.** Investigation of uncertainty in vibromonitoring of rotating systems transient modes. *Journal of Vibroengineering*. ISSN 1392-8716. Vilnius. 2008. Vol. 10. No. 4. P.465-469.
8. **Grybos R.** *Dynamika maszyn wirnikowych*. Polska Akademia Nauk. Warszawa. 1994. P. 110-113.

V. Volkovas, A. Perednis

Didelės galios išcentrinų siurblių guolių virpesių koreliacijos tyrimas

Reziumė

Apartos keturių vienetų didelės galios išcentrinų siurblių virpesių padidėjimo priežastys ir koreliaciniai ryšiai esant skirtingiems darbiniam sūkiams, apibūdinta guolių korpusų ir rotoriaus standumų įtaka virpesių dydžiams.

Naudojantis vieno iš šių siurblių guolių virpesių koreliacinių ryšių ankstesnio tyrimo rezultatais patikrintas duomenų objektyvumas kitų siurblių atžvilgiu. Virpesių koreliacinių ryšių pokyčiai paaiškinti skirtingais dinaminiais modeliais dviejuose būdinguose darbinų sūkių ruožuose.

Be to, išnagrinėtas šių tyrimų duomenų matavimo neapibrėžties modelis ir parodyta, kad suminė neapibrėžtis nedaro esminio poveikio virpesių dydžiams ir jų pokyčiams, nustatytiems tiriant koreliaciją.

Pateikta spaudai 2009 10 08

DOI: 10.5755/j01.u.64.4.17124