

УДК 621.314.631: 681.586

Transducers with piezoelements in circuits of electric filters

V. Sharapov¹, R. Kažys², A. Vladiškauskas², L. Kunitskaya¹, Zh. Sotula¹, V. Tuz¹, K. Bazilo¹

*1 - Cherkasy State Technological University,
460, Shevchenko Blvd., Cherkasy, Ukraine,*

E-mail: v_sharapov@rambler.ru

2 - Kaunas University of Technology,

Studentu56-350, LT-51424 Kaunas, Lithuania,

Abstract

Transducers with piezoelements in electric filters are developed and investigated. Inclusion of piezoelements in to circuits of filters has allowed to obtain amplitude-frequency responses (AFR), corresponding to these filters, and thus to expand their frequency range. However, the drawback of the mentioned transducers is necessity of use for some schemes of two piezoelements or a piezoelement and the condenser. For elimination of this shortcoming it is proposed to use in circuits of piezotransformers also. Besides, for one or for two systems it is offered to put electrodes so that the electric field vector between these electrodes would be at the angle α to a polarisation vector. It allows to get electric voltage which exceeds the voltage for a conventional case when $\alpha = 0$ on these electrodes. Eight schemes of such transducers are developed. Computer models with which help it is possible to predict AFR of the transducers with piezoelements and piezotransformers in schemes of electric filters are developed.

Keywords: piezoceramic transducer, electric filter, dynamic characteristics.

Introduction

Piezoceramic transducers are widely used in hydroacoustics, electro-acoustics, in ultrasonic, medical and measuring technics, in scanning probe nanomicroscopes, piezoengines and in other areas of a science and technics.

Piezoelectric transducers occupy a special place in hydroacoustics, being in essence, with ears and eyes of the underwater and surface ships.

Widely enough in transducers of different functions are applied bimorph piezoelements which usually consist of a disk piezoelement and the metal plate, joined among themselves by means of glue or fusible solder [1-3].

The bimorph piezoelements possess 10 times higher sensitivity, than monomorph, however have a narrow working frequency range.

Resonant frequency of a bimorph element can be defined approximately under the formula [4]:

$$f_0 \approx \frac{0,45Ch}{r^2 \sqrt{1-\mu^2}}, \quad (1)$$

where $C = \sqrt{E\rho}$, h is the thickness of a piezoelement, r is the piezoelement radius, E – Young's module, ρ is the density of a material of a piezoelement, μ is the Poisson's coefficient.

In practice the resonant frequency of used bimorph elements usually is of the order of some kilohertz [3].

Problem and approach

Some methods of expansion of a working frequency range are known. Most obvious of them consists in decrease transducer overall dimensions, however sensitivity thus decreases. Besides, this method is not suitable for low-frequency radiators [3]. One more method consists in use of a spatial energy force structure of a piezoelement [4]. The method which consists in

introduction of a spatial electromechanical feedback is interesting also, however it leads to more complicated transducer design.

Let's consider in this work possibility of expansion of a working range of frequencies of transducers by inclusion of piezoelement in to circuits of electric filters.

The idea is based on a creation of such transducers that the piezoelement (piezoelements) included in to the scheme of the electric filter would possess the amplitude-frequency responses (AFR), which corresponds to the AFR of the filter.

Electric filters are well enough studied and described in [6, 7]. As the electric filter is called the device serving for allocation (or suppression) electric voltage or currents of the selected frequency.

Depending on characteristics some types of filters from which the greatest interest for the given case is represented by filters of the low-pass and high-pass are known.

Low-pass filters (LPF) pass oscillations of all frequencies from a direct current and to some top cut-off frequency ω_c .

High-pass filters (HPF) pass oscillations from some cut-off frequency ω_b to infinitely high frequencies.

In order the transducer would have AFR of the filter, the piezoelement or piezoelements are included in to the circuit of the filter instead of condensers.

Results

Two cases of the transducer with piezoelements in low-pass filter are shown in Fig. 1 [8-10].

In this case force F is applied to on one of the piezoelements (PE1). The second piezoelement is used as a condenser.

For investigation the transducer on a basis of a bimorph element which consists of a metal plate from

brass Ø36 with the thickness of 0,3 mm and a piezoement from piezoceramic element IITC-19 with the diameter 30 mm and thickness 0,8 mm was used. The basic resonant frequency of the transducer oscillations - 3,5 kHz.

Results of the computer modelling of the transducer presented in Fig. 1a, by means of the package MicroCap 9.6.1, are shown in Fig. 2.

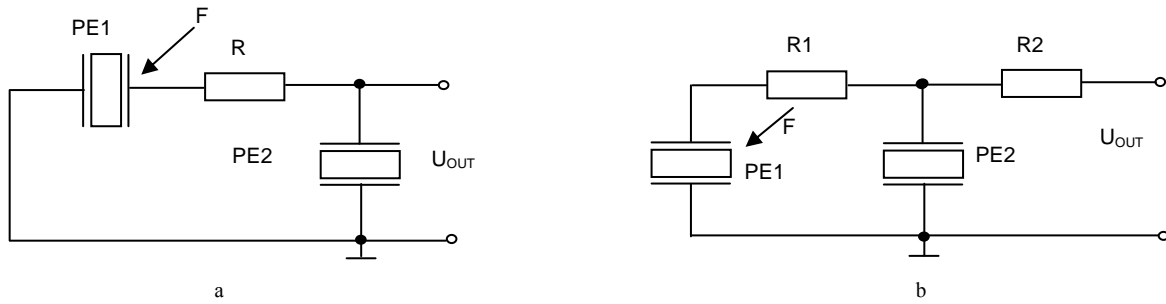

Fig. 1. Transducers of mechanical quantities with piezoelements in low-pass filter

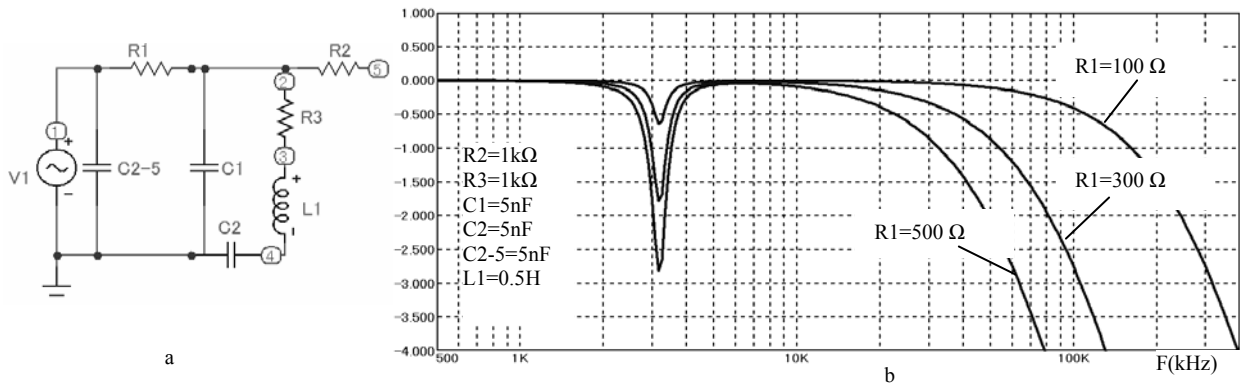

Fig. 2. The equivalent circuit and amplitude-frequency response (AFR) of the transducer (Fig. 1a): a - the equivalent circuit, b - the amplitude-frequency responses at different R1 when R3=1kΩ, C1=5nF, C2=5nF, C2-5=5nF L1=0.5H

Apparently from Fig. 2, AFR of the transducer depends on a resistance of the resistor R1. On AFR there is a blockage on frequency 3,5 kHz, corresponding to the resonant frequency of the bimorph element.

Similar results are obtained for the transducers shown in Fig. 1b.

Two schemes of the transducer with piezoelements in the HPF are shown in Fig. 3 [11-14].

In the transducer (Fig. 3a) the force F acts only on one piezoelement (PE1). In the second case (Fig. 3b) the force is applied to both piezoelements.

Results of computer modelling of the transducer presented in Fig. 3 shown in Fig. 4.

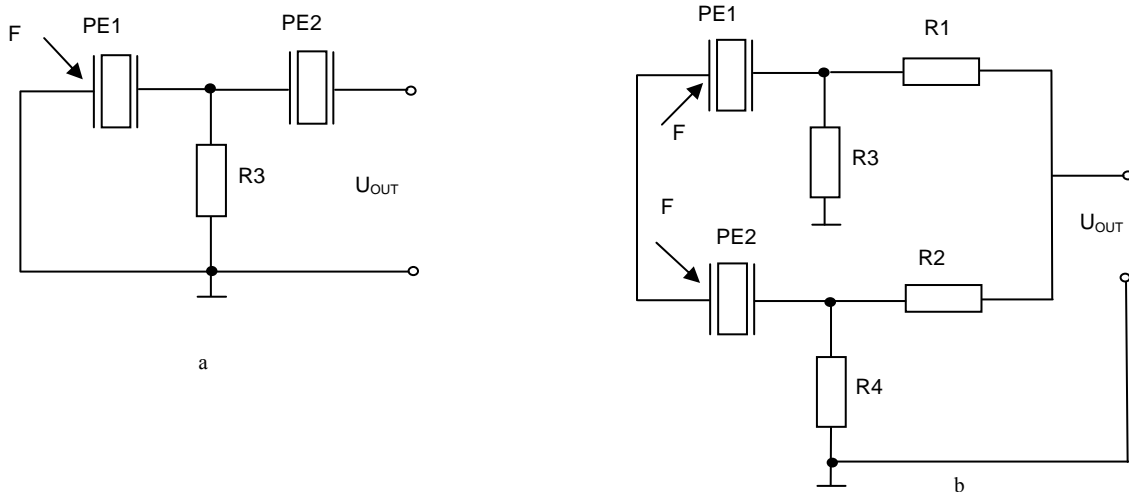

Fig. 3. Transducers of mechanical quantities with piezoelements in the HPF

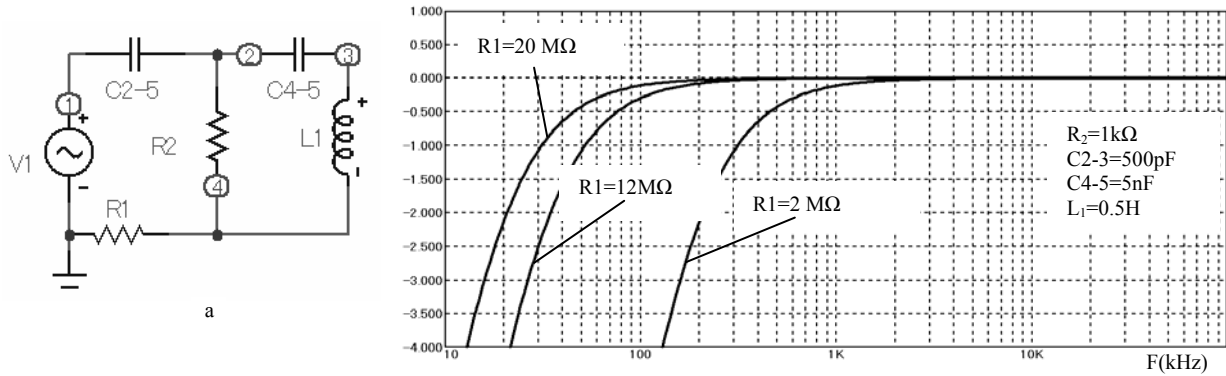

Fig. 4. The equivalent circuit and AFR of the transducer (Fig. 3a): a - the equivalent circuit, b - the amplitude-frequency responses at different values of resistance R1 at R2=1kΩ, C2-5=500pF, C4-5=5nF, L1=0.5H

Apparently from the results of modelling AFR of the sensor depends on a value of the resistance R3.

Similar results are received for the transducer (Fig. 3b).

Disadvantage of the mentioned transducers is necessity of use of two piezoelements or a piezoelement and the condenser.

For elimination of this disadvantage it is offered to use piezotransformers, that is, the piezoelements with two systems of electrodes.

Besides, for one or for two systems it is proposed to put electrodes so that the electric field vector between these electrodes would be at the angle α to the polarisation vector ($0 < \alpha \leq 90^\circ$). It allows to get on these electrodes electric voltage, which exceeds the voltage for a traditional case when $\alpha = 0$ [3, 5].

Some circuit diagrams of the transducers implementing these ideas, are shown in Fig. 5 [14-17].

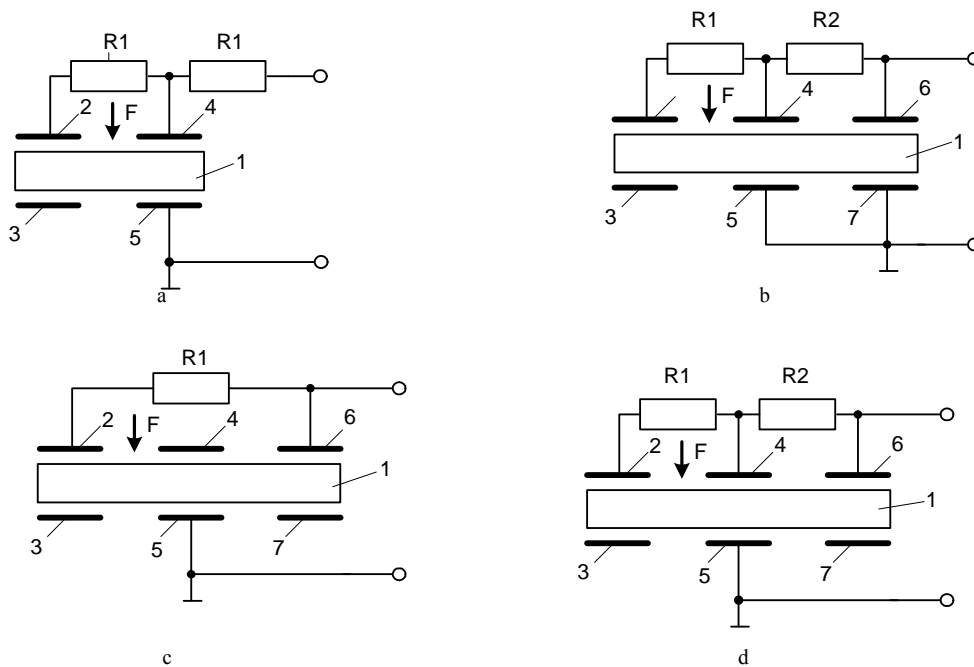

Fig. 5. Piezotransducers with piezotransformers in low-pass filters

The transducer of mechanical quantities (Fig. 5a) contains a piezoelement 1 with two systems of electrodes 2, 3 and 4, 5 and resistors R1 and R2. The resistors are connected to the electrodes of the piezoelement and the transducer's output. The electrode 5 is connected to the common ground. The electrodes 2, 3, 4 and 5 have the identical area, therefore at identical mechanical influence on them the identical electric charge is formed.

Meanwhile, capacity C2-5 between the electrodes 2 and 5 much less capacities C4-5 between electrodes 4 and

5. It is related, obviously, to the bigger distance between electrodes and, probably, change of the dielectric permeability in a piezoelectric material as capacity measurements are made at the angle α ($0 < \alpha \leq 90^\circ$) to the polarisation vector \mathbf{P} [3]. Therefore, the electric voltage on the electrode 2 is higher, than on the electrode 4 what creates favorable conditions for the transducer and filter operation.

For experiments the piezoelement made of the piezoceramic element ИТC-19 with the diameter 30 mm

and thickness of 0,8 mm and a metal plate made of brass Л63 with the diameter 36 mm and the thickness of 0,3 mm was used.

Computer modelling of piezoceramics transducers was carried out by means of the program MicroCAP which allows to predict the amplitude-frequency responses of the transducer.

The equivalent circuit and the amplitude-frequency responses of the transducer constructed under the scheme given in Fig. 5a, are shown in Fig. 6.

In the equivalent circuit (Fig. 6a) parameters of the L1, C2, R3 correspond to the dynamic parameters of the bimorph piezoelement, capacity C1 - interelectrode capacity C4-5. The electric voltage on the electrode 2 is presented by the generator V1.

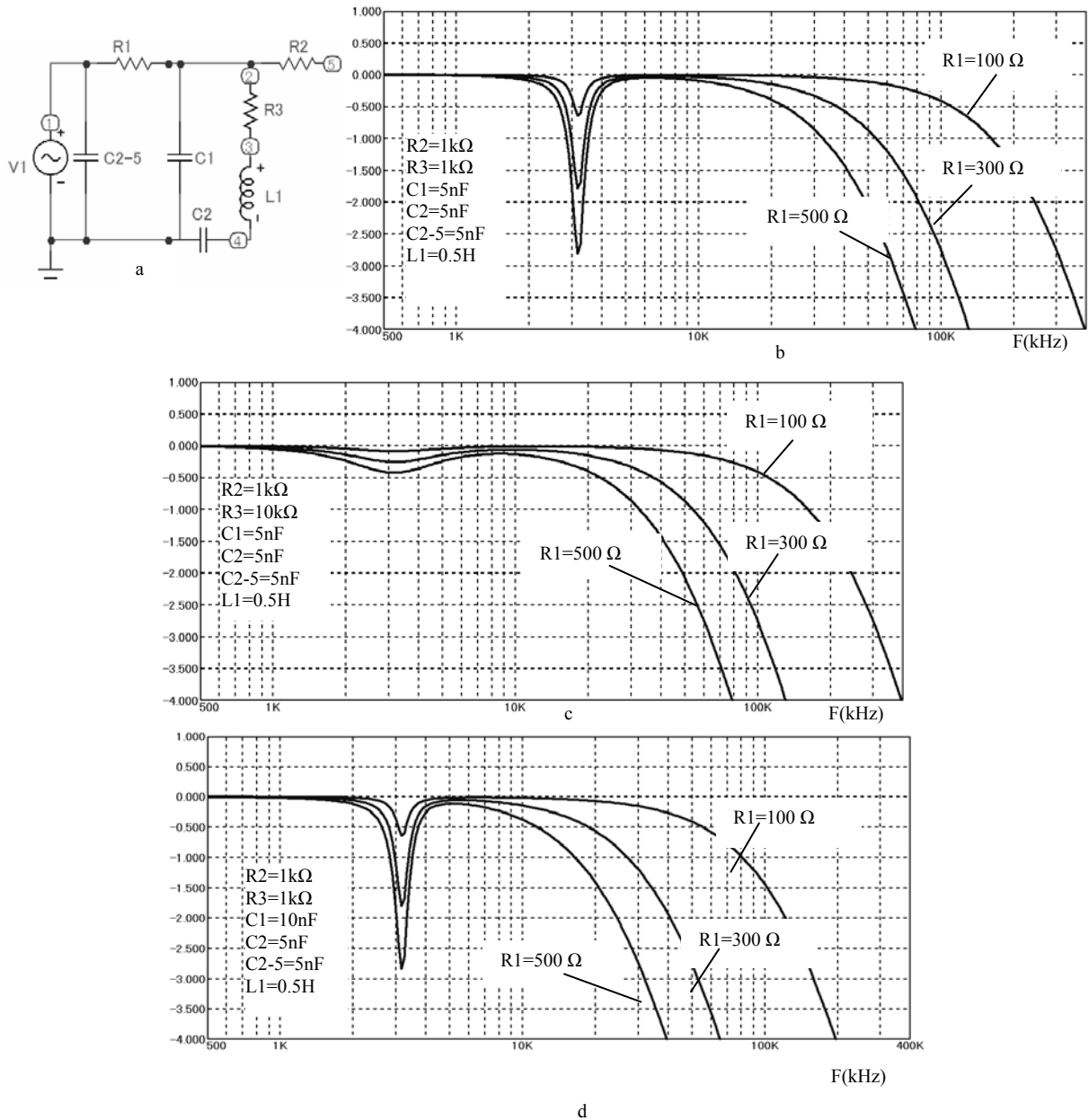

Fig. 6. The equivalent circuit and AFR of the transducer (Fig. 5a): a - the equivalent circuit, b - the amplitude-frequency responses at different values of the resistance R1 at R3=1kΩ, C1=5nF, C2=5nF, C2-5=5nF L1=0.5H, c - the amplitude-frequency responses at different values of the resistance R1 at R2=10kΩ, C1=5nF, C2=5nF, C2-5=5nF L1=0.5H, d - the amplitude-frequency responses at different values of the resistance R1 at R3=1kΩ, C1=10nF, C2=5nF, C2-5=5nF L1=0.5H

From Fig. 2, follows that on the AFR there is "failure" at the frequency ~ 3,5 kHz, corresponding resonant frequency of bimorph a piezoelement. Depth of this "failure" depends on a quality of the bimorph element, that is, on the value of the resistance R3.

The linearity AFR and the bandwidth depends on the

resistance R1.

The transducer (Fig. 5b) differs from the transducer in Fig. 5a by the additional circuit R2 - C6,7 which enables one more integration of the input signal formed on the electrode 2.

The equivalent circuit and amplitude-frequency response of the transducer constructed under the scheme Fig. 5b are shown in Fig. 7.

From Fig. 7, follows that in this case the transducer has more linear frequency characteristic.

The transducer's scheme (Fig. 5c) differs from the scheme in Fig. 5a that in this case the systems of electrodes 2-3, 4-5, 6-7 is used.

The electrode 5 is connected to the common ground of the circuit. The area S_2 of the electrode 2 is less than area S_5 of the electrode 5, and the area S_6 of the electrode 6 is equal to the area S_5 , that is $S_2 < S_5$ and $S_5 = S_6$.

Therefore, the interelectrode capacities $C_{2-5} < C_{5-6}$, and consequently, electric voltage on the electrode 2 turns out more than on the electrode 6. It is experimentally established also, that the resonant frequency of the bimorph transducer increases.

The equivalent circuit and amplitude-frequency responses of the transducer constructed under the scheme Fig. 5c are shown in Fig. 8.

The equivalent circuit and amplitude-frequency responses of the transducer constructed under the scheme Fig. 5d are shown in Fig. 9.

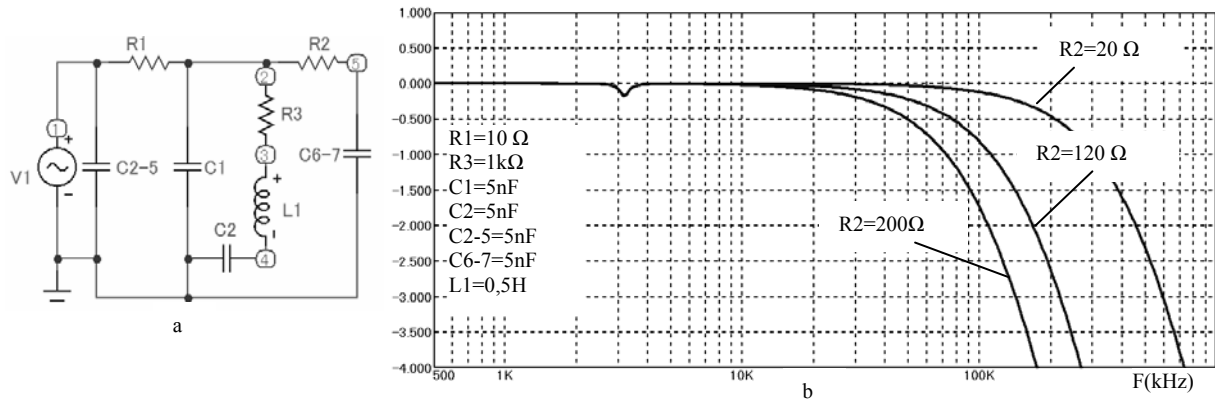

Fig. 7. Equivalent circuit and AFR of the transducer (Fig. 5b): a - the equivalent circuit, b - the amplitude-frequency responses at various values of the resistance R_2 at $R_1=100\Omega$, $C_1=5nF$, $C_2=5nF$, $C_{2-5}=5nF$, $C_{6-7}=5nF$, $L_1=0,5H$

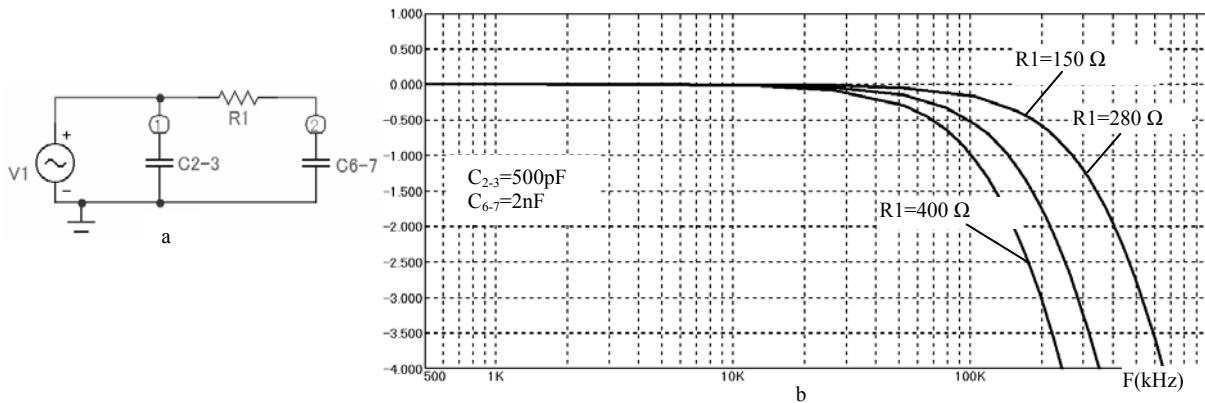

Fig. 8. Equivalent circuit and AFR of the transducer (Fig. 5c): a - the equivalent circuit, b - the amplitude-frequency responses at various values of the resistance R_1 at $C_{2-3}=500pF$, $C_{6-7}=2nF$

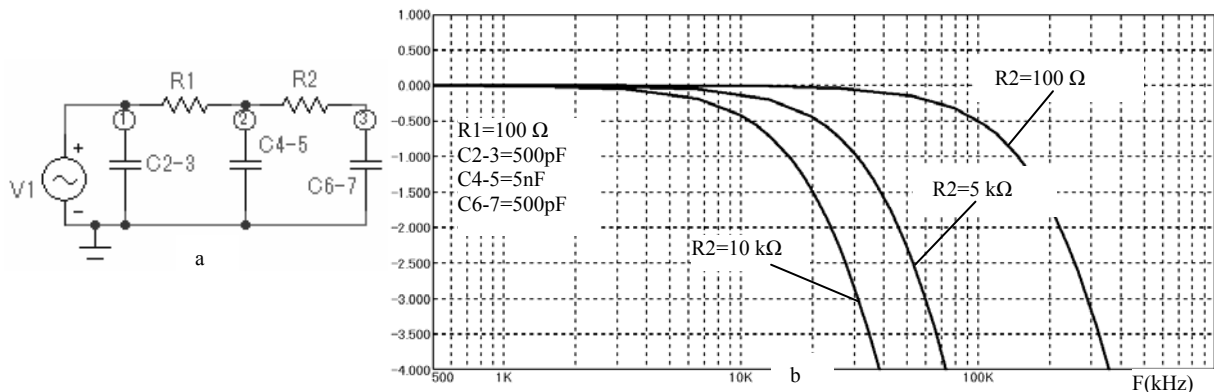

Fig. 9. Equivalent circuit and AFR of the transducer (Fig. 5d): a - the equivalent circuit, b - the amplitude-frequency responses at various values of the resistance R_2 at $R_1=100\Omega$, $C_{2-3}=500pF$, $C_{4-5}=5nF$, $C_{6-7}=500pF$

Some transducers with piezotransformers in high-pass filters are shown in Fig. 10 [18-21].

The transducer (Fig. 10a) contains a piezoelement 1 with two systems of electrodes 2, 3 and 4, 5 and resistor R1. The electrode 4 is connected to the transducer's input. The electrode 5 is connected through resistor R1 to the electrode 2 and the common ground of the circuit. Electrodes 2, 3, 4 and 5 have the identical areas, therefore at identical mechanical influence on them the identical electric charge is formed. Meanwhile, capacity C_{2-5} between the electrodes 2 and 5 is much less than the capacity C_{4-5} between the electrodes 4 and 5. It is related, obviously, to the bigger distance between electrodes and, probably, change of dielectric permeability in a piezoelectric material, as capacity measurements are made

to the angle α ($0 < \alpha \leq 90^\circ$) to a vector of polarisation P [3].

For experiments the piezoelement made from piezoceramic ПТС-19 with the diameter 30 mm and thickness of 0,8 mm and a metal plate made from brass Л63 with the diameter 36 and the thickness of 0,3 mm was used.

Computer modelling of piezoceramics transducers was carried out by means of the program MicroCAP, which allows to predict the amplitude-frequency response of the transducer.

The equivalent circuit and amplitude-frequency responses of the transducer constructed under the scheme Fig.10a, are shown in Fig.11.

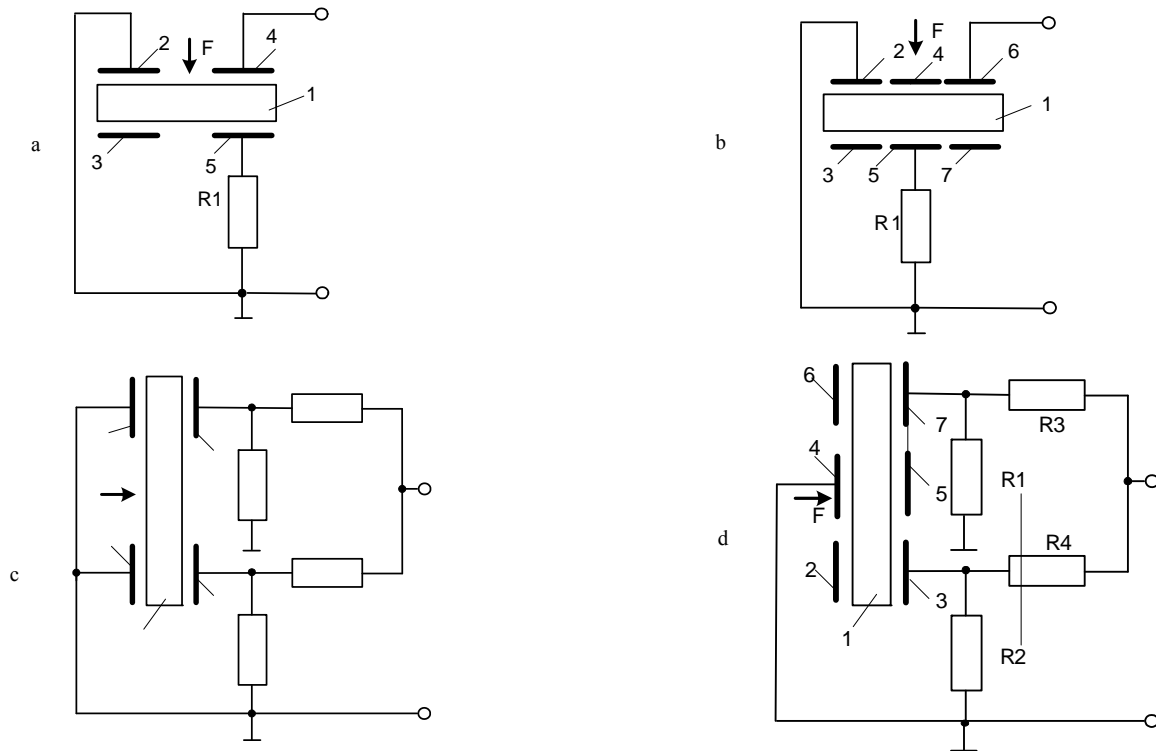

Fig. 10. Transducers with piezotransformers in schemes of HPF

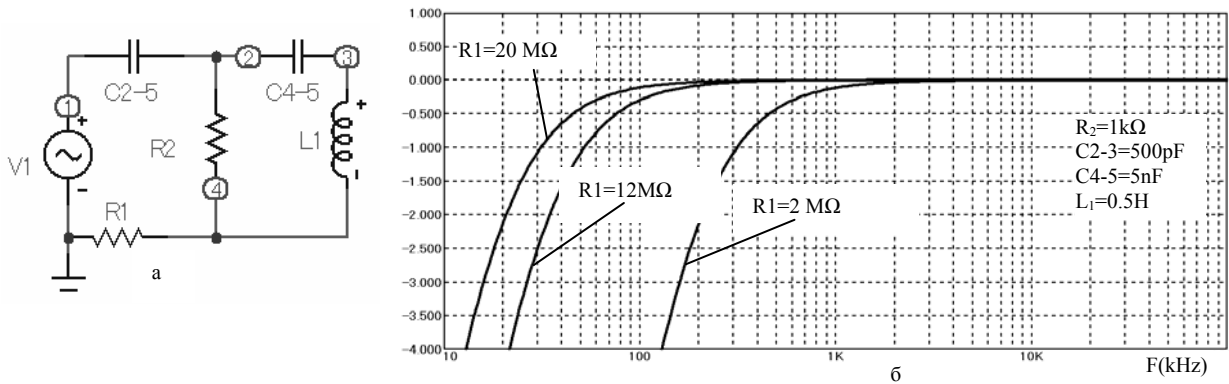

Fig.11. Equivalent circuit and AFR of the transducer (Fig. 10a): a - the equivalent circuit, b - the amplitude-frequency responses at various values of the resistance R1 at R2=1kΩ, C2-5=500pF, C4-5=5nF, L1=0.5H

From Fig. 11 follows that the transducer has a linear AFR and the bandwidth of a working frequencies depends on resistance R1.

The transducer (Fig. 10b) differs from the transducer (Fig. 10a). The transducer has three systems of electrodes 2-3, 4-5, 6-7. The electrode 5 is connected to the resistor

R1, the electrode 2 - with the general wire, the electrode 6 - with a transducer's output.

The equivalent circuit and amplitude-frequency responses of the transducer constructed under the scheme Fig.10b, are shown in Fig.12.

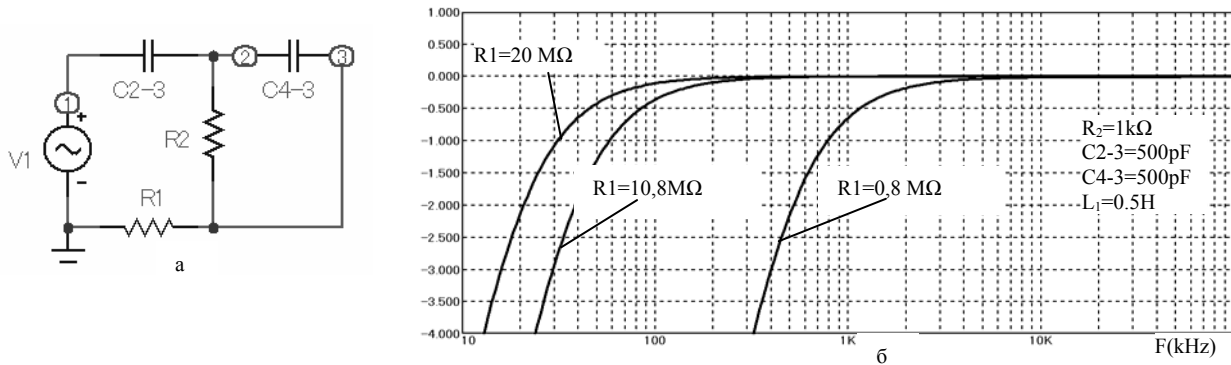

Fig. 12. Equivalent circuit diagram and AFR of the transducer (Fig. 10b): a - the equivalent circuit, b - the amplitude-frequency responses at different values of resistance, R1 at C2-3=500pF, C4-3=500pF, L1=0.5H

Apparently from Fig. 12, in this case the transducer has a more linear frequency characteristic at smaller values R1.

The transducer scheme (Fig. 10c) differs from the scheme in Fig. 10a that two pairs systems of electrodes 2-3 and 4-6, and four resistors in this case are used. The electrodes 2 and 4 are connected to the common ground. The electrode 3 is connected to the resistors R2 and R4, and R2 the second conclusion of resistor R4 - with a

transducer's output is connected to the general wire, and. The electrode 5 is connected to the resistors R1 and R3. The resistor R1 is also connected to the common ground and the resistor R3 - to a transducer's output. The equivalent circuit and amplitude-frequency responses of the transducer constructed under the scheme presented in Fig. 10c are shown in Fig. 13.

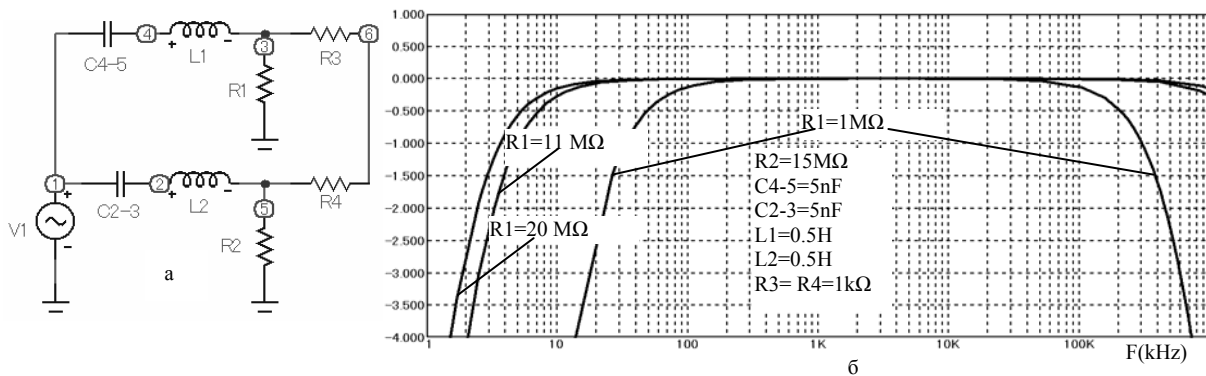

Fig. 13. Equivalent circuit diagram and AFR of the transducer (Fig. 10c): a - the equivalent circuit, b - the amplitude-frequency responses at different values of resistance R1 at C2-3=5nF, C4-5=5nF, R2=15 MΩ, R3= R4=1kΩ, L1=L2=0.5H

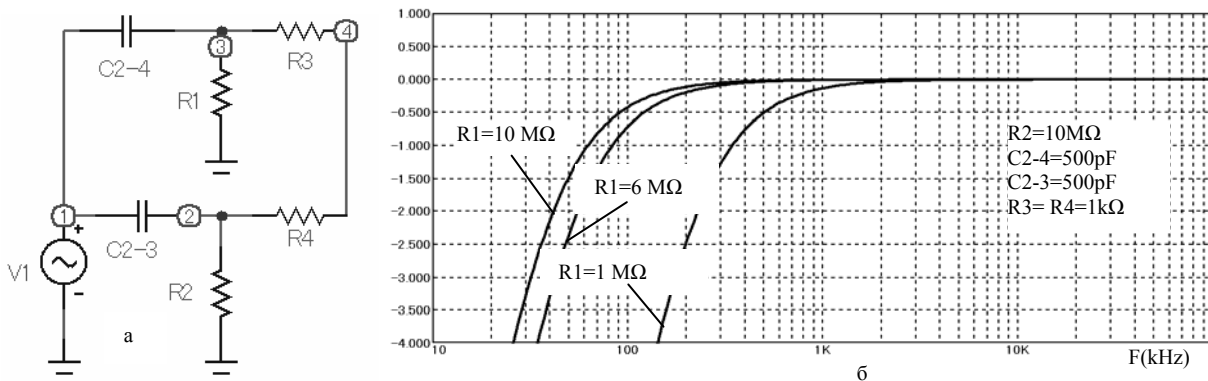

Fig. 14. Equivalent circuit diagram and AFR of the transducer (Fig. 10d): a - the equivalent circuit, b - the amplitude-frequency responses at different values of resistance R1 at R2=10 MΩ, C2-3=500pF, C2-4=500pF, R3= R4=1kΩ

Apparently from Fig. 13, a working frequency range of this transducer is essentially wider.

The equivalent circuit diagram and amplitude-frequency responses of the transducer's constructed according to Fig. 10d, are shown in Fig. 14.

Apparently from Fig. 11-14, by selecting corresponding resistance and piezoelement capacitance it is possible to increase a working frequency band 10-15 times and more.

Conclusions

1. Transducers with piezotransformers in electric filters were developed and investigated.

2. Application in the piezotransformer of integrating and differentiating circuits has allowed to expand a working range of frequencies of the transducer, thus AFR remains linear in a wide range of frequencies.

3. Computer models were developed, with which help it is possible to predict AFR of the transducers with piezotransformers in high-pass electric filters.

References

1. **Domarkas V., Kažys R.-J.** Piezoelectric transducers for measuring devices. Vilnius: Mintis. 1974. P.258 (in Russian).
2. **Kažys R.-J.** Ultrasonic information measuring systems. Vilnius: Mokslas. 1986. P. 216.
3. **Sharapov V. and others.** The piezoelectric sensors. Under red. V. M. Sharapov. Moscow: Technosfera. 2006. P. 632 (in Russian).
4. Piezoceramic transducers: The directory / Ed. S. I. Pugachev. L.:Sudostroenie. 1980. P.232 (in Russian).
5. **Sharapov V., Vladišauskas, Bazilo K., Kunitskaya L., Sotula Zh.** Methods of synthesis of piezoceramic transducers: spatial energy force structure of piezoelement. ISSN 1392-2114, Ultragarsas (Ultrasound). Kaunas: Technologija. 2009. Vol. 64, No. 4. P. 44-50.
6. **Titse U., Shenk K.** Semi-conductor circuitry. M.:Mir. 1983 (in Russian).
7. **Kaufman M., Sidman A. G.** Practical guidance by calculations of schemes in electronics. The directory / Ed. F. N. Pokrovskiy.
8. **Sharapov V. M., Trembovetskaya R. V. and others.** Piezoelectric transducers of mechanical quantities with a piezoelement in the scheme of the filter bottom frequencies. Bulletin of Cherkasy State Technological University. 2005. № 1. P.86-89 (in Russian).
9. Patent of Ukraine № 8606. Piezoelectric transducers of mechanical quantities. Sharapov V. M., Musienko M. P., Trembovetskaya R.V. Publication 15.08.2005 (in Ukrainian).
10. Patent of Ukraine № 8609. Piezoelectric transducers of mechanical quantities. Sharapov V. M., Trembovetskaya R. V. Publication 15.08.2005 (in Ukrainian).
11. **Sharapov V. M., Trembovetskaya R. V.** Piezoelectric transducers of mechanical quantities with a piezoelement in the scheme of the filter top frequencies. Bulletin of Cherkasy State Technological University. 2005. № 2. P.32-35 (in Russian).
12. Patent of Ukraine № 8613. Piezoelectric transducers of mechanical quantities. Sharapov V. M., Trembovetskaya R. V. 2005 (in Ukrainian).
13. Patent of Ukraine № 8604. Piezoelectric transducers of mechanical quantities. Sharapov V. M., Trembovetskaya R. V., Musienko M. P. 2005 (in Ukrainian).
14. Patent of Ukraine for application №U2010.00638 from 22.01.2010. Piezoelectric transducers of mechanical quantities. Sharapov V. M. and others (in Ukrainian).
15. Patent of Ukraine for application №U2010.00623 from 22.01.2010. Piezoelectric transducers of mechanical quantities. Sharapov V. M. and others (in Ukrainian).
16. Patent of Ukraine for application №U2010.00620 from 22.01.2010. Piezoelectric transducers of mechanical quantities. Sharapov V. M. and others (in Ukrainian).
17. Patent of Ukraine for application №U2010.00616 from 22.01.2010. Piezoelectric transducers of mechanical quantities. Sharapov V. M. and others (in Ukrainian).
18. Patent of Ukraine for application №U2010.00617 from 22.01.2010. Piezoelectric transducers of mechanical quantities. Sharapov V. M. and others (in Ukrainian).
19. Patent of Ukraine for application №U2010.00618 from 22.01.2010. Piezoelectric transducers of mechanical quantities. Sharapov V. M. and others (in Ukrainian).
20. Patent of Ukraine for application №U2010.00619 from 22.01.2010. Piezoelectric transducers of mechanical quantities. Sharapov V. M. and others (in Ukrainian).
21. Patent of Ukraine for application №U2010.00621 from 22.01.2010. Piezoelectric transducers of mechanical quantities. Sharapov V. M. and others (in Ukrainian).

V. Sharapov, R. Kažys, A.Vladišauskas, L. Kunitskaya, Zh. Sotula, V. Tuz, K. Bazilo

Pjzokeitikliai elektrinių filtrų schemose

Reziumė

Sukurti ir tyrinėjami pjzokeitikliai elektrinių filtrų schemose. Pjzoelementų taikymas filtrų schemose įgalina gauti amplitudines - dažnines charakteristikas, tokios kaip elektriniuose filtruose ir praplėsti jų darbinį dažnių sritį. Darbe siūlomos schemos su pjzotransformatoriais, kai elektrodai išdėstomi taip, kad elektrinio lauko vektorius būtų kampu α į poliarizacijos vektorių. Tai leidžia gauti įtampą, kuri viršija įtampą gaunamą tradiciniu atveju, kai kampas ant šių elektrodų $\alpha = 0$. Pasiūlytos tokių filtrų aštuonios schemos.

Pateikta spaudai 2010 02 17

DOI: 10.5755/j01.u.65.1.17138