

## Modeling of adaptive hydrodynamic segmental bearings

A. Čereška, V. Vekteris

*Vilnius Gediminas Technical University, Mechanic Faculty, Department of Machine Building,*

*Basanaviciaus str. 28, LT-03224 Vilnius, Lithuania,*

*Phone: +370 5 2370573, +370 5 2744734, Fax. +370 5 2745043,*

*E-mail: [audrius.cereska@vgtu.lt](mailto:audrius.cereska@vgtu.lt), [vekteris@vgtu.lt](mailto:vekteris@vgtu.lt)*

### Abstract

There are a lot of mechanics vibrant systems in the modern technique, therefore research of vibrations have a big academic and practical importance. Physical, dynamic and mathematic modeling is done researching modern systems.

Adaptive hydrodynamic segmental bearings of several constructions are researched in this paper. The method of modeling of this type bearings and principles are given. Dynamic and mathematical models of adaptive hydrodynamic bearings are created.

**Keywords:** rotor, bearing, segments, dynamic model, mathematic model, signal, amplitude, frequency

### Introduction

Bearings of roll and of sliding friction are used very widely in industry. These bearings working with sliding friction principle for roll bearings work more accurately and with considerably higher revolution frequencies. There are investigative works for diagnostic of sliding friction bearings and for creation of diagnostic methods and for analysis less largely than for systems with roll bearings [1, 2].

This situation is due to many reasons. One of them is that, hydrodynamic bearings are characterized with a little vibroactivity and then it is easy to substantiate vibrosignal, that is interflowed with different noises. Different internal and external factors also act in a rotary system [1, 2].

There are a lot of constructions of adaptive hydrodynamic bearings, because hydrodynamic bearings are used in different rotary systems: in rotor knots of different machines, turbines of vapor and gas of a big power, powerful electro motors, ventilators, compressor, pumps, generators, mechanism of ships of a big turning frequencies and in others mechanismus [3, 4].

Different scientists of the world and Lithuania investigated bearings of this type, its results they had published in [5-14].

Physical model is made researching these bearings theoretically and is done using dynamic and mathematic modeling [15, 16, 17, 18, 19]. Made model is important to anticipate to characteristics of real object as far as more possible. The main stage of modeling is the formation of dynamic and mathematic models. The correct results of model solution are gotten only making it correctly. It needs to perform experimental researches, and then getting results are equated and there are fixed errors. Model can be corrected appreciating errors [16].

The first object of these researches is to determine chance of modeling and security, the basic consistent patterns of work, reasons of breakdowns, influence of outside factors and chances of diagnostic with methods of all-it-on control [20] which are in the systems with mounted hydrodynamic bearings of sliding frequency.

### Stages of modeling of rotary systems with adaptive hydrodynamic bearings

There are a lot of mechanical vibratory systems in a modern technique, therefore investigation of vibrations have a big academic and practical interest. Physical, dynamic and mathematic modeling is done researching modern systems.

The whole process of vibrodiagnostic researches are taken on Fig. 1 [16].

Process of vibrodiagnostic researches includes 12 essential stages:

1. The object is chosen in the first;
2. Physical model of researching object is structured.
3. Dynamic model of research object is created for analytic vibrodiagnostic research. The research system is simplified and none but what needs for subsequent research is left in the model. It is tried to make dynamic model simple over downgrading, but it to leave and herewith such as, that it can investigate vibrations of object with due truth. Several dynamic models may structure, and from it can be choosing one or some to research further. One dynamic model is researched on the docked case;
4. Mathematic model of chosen dynamic mode is structured;
5. Resolution of mathematic model is done;
6. Numerical model is created;
7. Decision of numerical model is done;
8. The obtained resolutions are analyzed, structural and parametric optimistic synthesis is done (structure of dynamic model and of own object from which that model is made are corrected, parameters of dynamic model are changed expediently, that its characteristics are passed provided parameters early);
9. Appealing to results of analysis and synthesis, it makes recommendations to improve object;
10. Doing analytic stages of research or before even, experiments can be carried out. Character of vibrations and operation are researched;
11. Physical origin of vibrations are determined, it is ascertained vibrations that are sprigged up in the

object, is they are forced, or spontaneous, linear or no linear, sources of vibrations excitation are determined and so on.

12. The obtained analytical and experimental results of research are leveled.

Data of experiments, reasons of vibrations coming especially needs to know in all stages of analytical

researches, but in the first instance – for making dynamic object of the investigated object.

The described scheme (Fig. 1) of vibrodiagnostic researches could be done not all.

There are a lot of different mechanic, mechatronic and other systems, that research of vibrations have a big pure and practice meaning in modern technique.

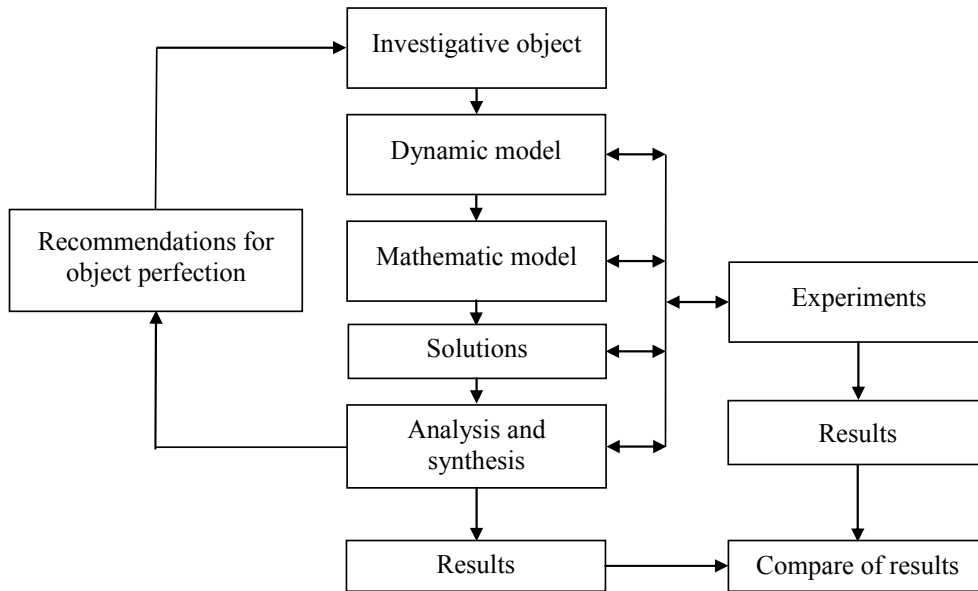

Fig. 1. Principal scheme of modeling step

### Modeling of adaptive hydrodynamic segmental bearings

Dynamic and mathematic modeling is an important stage researching adaptive hydrodynamic bearings [16, 17]. In Fig. 2a is taken the physical model of adaptive hydrodynamic bearing and in Fig. 2b – dynamic model.

The position „0“ of rotor centre lies with rotor rotation frequency  $\omega$ . When rotor rotation frequency is fixed  $\omega = const$ , the position „0“ of the centre is fixed theoretically.

The system of coordinates  $xOy$  is introduced. Forces  $F_x, F_y$  are upstarted being small changes in the coating of

lubricant, forces are tried to restore the rotor to primary position, that is - to a stable position of the rotor rotation. Term of effect of these forces:

$$\begin{aligned} F_x &= -C_{xy}y - C_{yx}x - K_{yy}\dot{y} - K_{yx}\dot{x}, \\ F_y &= -C_{yy}y - C_{xx}x - K_{xy}\dot{y} - K_{xx}\dot{x}, \end{aligned} \quad (1)$$

where  $C_{xy} \neq C_{yx}$ ,  $K_{xy} \neq K_{yx}$ ;  $C_{ij}$  and  $K_{ij}$  - stable coefficients. These coefficients are different for bearings of different types.

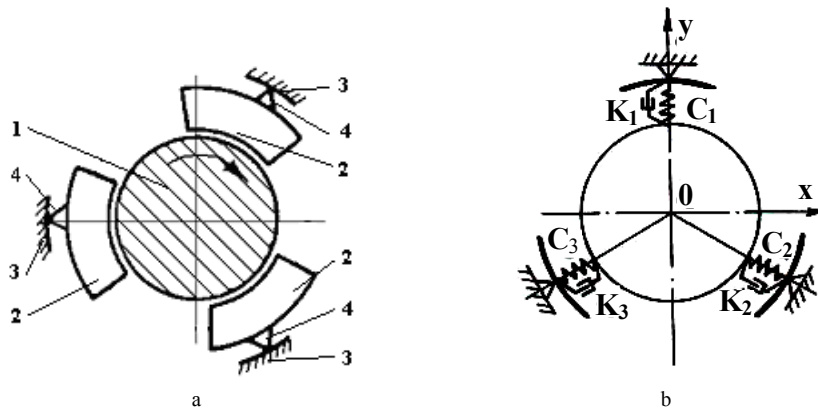

Fig. 2 Adaptive hydrodynamic bearings: a – physical model, 1 - rotor, 2 – segments 3 - spindle head 4 - adaptive thrust; b – dynamic model,  $K_1, K_2, K_3$  - coefficients of rigidity,  $C_1, C_2, C_3$  - coefficients of elasticity.

**Modeling of adaptive hydrodynamic bearings with shoulders that are connected segments**

Dynamic model is made having adaptive hydrodynamic bearings with shoulders that are connected (Fig. 3).

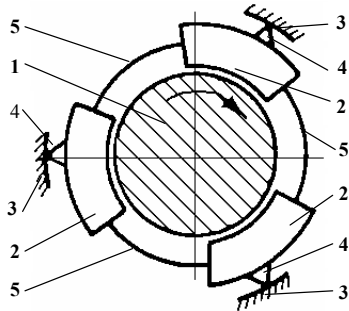

Fig. 3 Physical model of adaptive hydrodynamic bearings with elastic shoulders that are connected segments: 1 - rotor, 2 – segments 3 - spindle head 4 - adaptive thrust; 5 – several elastic shoulders that are connected segments

In the (Fig. 4) systems stress is created by preloading the connecting bands by way of radial displacement of the supporting elements.

The bending moment and normal force of bands assume the following value;

$$M_{0\varphi} = F_{0r\Lambda} \left[ \frac{1}{\beta} - \frac{\cos\left(\frac{\beta}{2} - \varphi\right)}{2\sin\frac{\beta}{2}} \right], \quad (2)$$

and

$$N_{0\varphi} = -\frac{F_0}{2\sin\frac{\beta}{2}} \cos\left(\frac{\beta}{2} - \varphi\right), \quad (3)$$

where  $F_0$  is the force from bearing elements applied to the segments;  $\beta = \frac{2\pi}{n}$  is the fixed angle which determine the position of the applied force  $F_0$ ;  $n$  is the number of concentrated forces  $F_0$   $\varphi$  is the current angle.

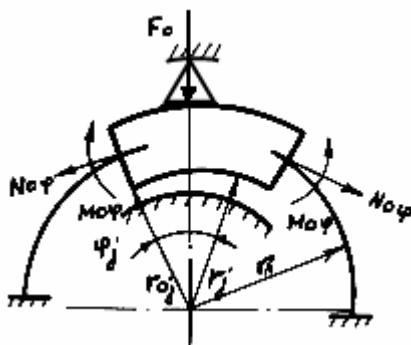

Fig.4. Powers that are operated on segments of bearing being preconceived weighting

In the the systems stress is created by the hydrodynamic pressure and temperature stress in the form of the existing moment  $M_{NT}$  (Fig. 5) which includes temperature and hydrodynamic components. The moment

of resistance of the band has the opposite direction. In this case the angle of rotation and the stress forces of the connecting bands can be determined by means of equations:

$$\begin{aligned} & \frac{\partial^2}{r_y^2 \partial \varphi^2} \left( D \frac{\partial^2 u_r}{r_y^2 \partial \varphi^2} \right) + \frac{2}{r_y^2 \partial \varphi \partial z} \left[ D(1-\nu) \frac{\partial^2 u_r}{\partial \varphi \partial z} \right] + \\ & + \frac{\partial^2}{\partial z^2} \left( D \frac{\partial^2 u_r}{\partial z^2} \right) = p - \frac{Eh_y u_r}{(1-\nu^2)r_y^2} + \frac{Eh_y \alpha T_0}{(1-\nu^2)r_y} - \\ & - \frac{\partial^2}{r_y^2 \partial \varphi^2} \left[ D(1+\nu) \frac{\alpha \Delta T}{h_y} \right]. \end{aligned} \quad (4)$$

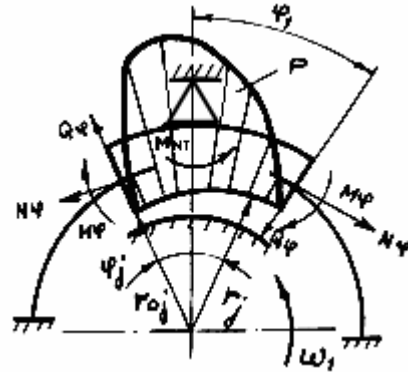

Fig.5. Powers that are operated on segments of bearing being hydrodynamic pressure

If moments of revolution are like 0, that Eq. 4 is simplified

$$\begin{aligned} & \frac{\partial^2}{r_y^2 \partial \varphi^2} \left( D \frac{\partial^2 u_r}{r_y^2 \partial \varphi^2} \right) + \frac{\partial^2}{\partial z^2} \left( D \frac{\partial^2 u_r}{\partial z^2} \right) = p - \frac{Eh_y u_r}{(1-\nu^2)r_y^2} + \\ & + \frac{Eh_y \alpha T_0}{(1-\nu^2)r_y} - \frac{\partial^2}{r_y^2 \partial \varphi^2} \left[ D(1+\nu) \frac{\alpha \Delta T}{h_y} \right]. \end{aligned} \quad (5)$$

Rigidity of connective shoulders of segments are given, it is proportionate to hydrodynamic pressure directly and it is proportionate to angle of segments turning conversely.

**Modeling of adaptive hydrodynamic bearings with elastic ring that is connected segments**

Dynamic model is made having adaptive hydrodynamic bearings with shoulders that are connected (Fig. 6).

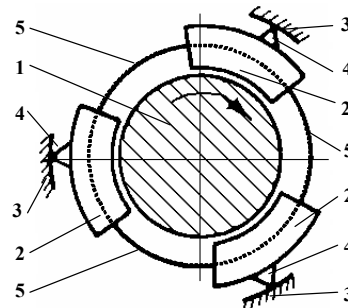

Fig.6. Physical model of adaptive hydrodynamic bearings with elastic ring that is moved easily and is connected segments: 1 - rotor, 2 – segments 3 - spindle head 4 - adaptive thrust, 5 - elastic ring

If no load is applied to a rotating cylinder then the equations of motion in the forces for free (Fig. 7) undamped vibrations will take the form:

$$\begin{pmatrix} m_y \ddot{y} \\ 0I_y \ddot{\varphi} \end{pmatrix} + \begin{pmatrix} C_y 0 \\ 0C_\varphi \end{pmatrix} \begin{pmatrix} y \\ \varphi \end{pmatrix} = \begin{pmatrix} 0 \\ 0 \end{pmatrix}, \quad (6)$$

where  $m_y, I_y$  - mass of the moving elastic element and its polar moment of inertia;  $C_y, C_\varphi$  - rigidity by coordinates  $y, \varphi$ .

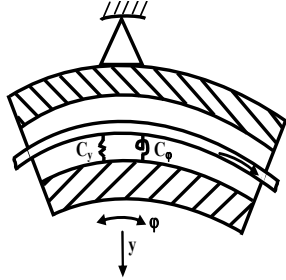

Fig. 7. Dynamic model, when elastic ring is empty

If a turbulent force acts on the elastic cylinder only in one segment (Fig. 8), the forced undamped vibrations will be described by the following equations:

$$\begin{pmatrix} m_y \ddot{Y} \\ 0I_y \ddot{\varphi} \end{pmatrix} + \begin{pmatrix} C_y 0 \\ 0C_\varphi \end{pmatrix} \begin{pmatrix} Y \\ \varphi \end{pmatrix} = \begin{pmatrix} F_y \\ M_\varphi \end{pmatrix}. \quad (7)$$

When the elastic cylinder is suspended in all segments the equations of motion will take on the form:

$$\begin{pmatrix} m_y \ddot{x} \\ 0m_y \ddot{y} \end{pmatrix} + \sum_{i=1}^n C_i \begin{pmatrix} \cos^2 \alpha_i \sin \alpha_i \cos \alpha_i \\ \sin \alpha_i \cos \alpha_i \sin^2 \alpha_i \end{pmatrix} \begin{pmatrix} x \\ y \end{pmatrix} = \begin{pmatrix} F_x \\ F_y \end{pmatrix}. \quad (8)$$

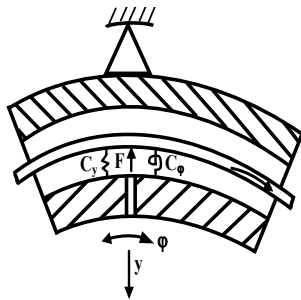

Fig. 8. Dynamic model, when elastic ring is laden only in one segment

If no load is applied to the elastic cylinder (Fig. 9), then its free vibrations under viscous damping are determined by the following equations of motion:

$$\begin{pmatrix} m_y \ddot{y} \\ 0I_y \ddot{\varphi} \end{pmatrix} + \begin{pmatrix} H_y 0 \\ 0H_\varphi \end{pmatrix} \begin{pmatrix} y \\ \varphi \end{pmatrix} + \begin{pmatrix} C_y 0 \\ 0C_\varphi \end{pmatrix} \begin{pmatrix} y \\ \varphi \end{pmatrix} = 0, \quad (9)$$

where  $H_y$  and  $H_\varphi$  - coefficients of viscous damping.

When the elastic cylinder is under the effect of perturbation in tangential openings of each segment (Fig. 10), the forced vibrations under viscous damping are determined by the following equations of motion:

$$\begin{pmatrix} m_y \ddot{x} \\ 0m_y \ddot{y} \end{pmatrix} + \sum_{i=1}^n C_i \begin{pmatrix} \cos^2 \alpha_i \sin \alpha_i \cos \alpha_i \\ \sin \alpha_i \cos \alpha_i \sin^2 \alpha_i \end{pmatrix} \begin{pmatrix} x \\ y \end{pmatrix} + \sum_{i=1}^m C_i \begin{pmatrix} \cos^2 \alpha_i \sin \alpha_i \cos \alpha_i \\ \sin \alpha_i \cos \alpha_i \sin^2 \alpha_i \end{pmatrix} \begin{pmatrix} x \\ y \end{pmatrix} = \begin{pmatrix} F_x \\ F_y \end{pmatrix}. \quad (10)$$

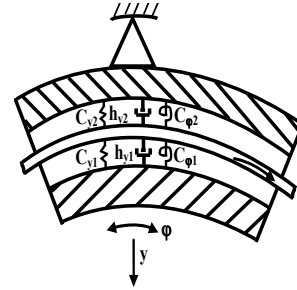

Fig. 9. Dynamic model, when segment is empty of elastic ring

In the same way the equation of motion for angular coordinates in the matrix expression takes on the following form:

$$\begin{pmatrix} I_y \ddot{\Theta} \\ 0I_y \ddot{\Theta} \end{pmatrix} + \sum_{i=1}^n H_{\Theta i} \begin{pmatrix} \cos^2 \alpha_i \sin \alpha_i \cos \alpha_i \\ \sin \alpha_i \cos \alpha_i \sin^2 \alpha_i \end{pmatrix} \begin{pmatrix} \Theta \\ \Theta \end{pmatrix} + \sum_{i=1}^m C_{\Theta i} \begin{pmatrix} \cos^2 \alpha_i \sin \alpha_i \cos \alpha_i \\ \sin \alpha_i \cos \alpha_i \sin^2 \alpha_i \end{pmatrix} \begin{pmatrix} \Theta \\ \Theta \end{pmatrix} = \begin{pmatrix} M_\varphi \\ M_\Theta \end{pmatrix}, \quad (11)$$

where  $H_{\Theta i}$  and  $C_{\Theta i}$  are the coefficients of viscous damping by coordinates  $\varphi$  and  $\Theta$ .

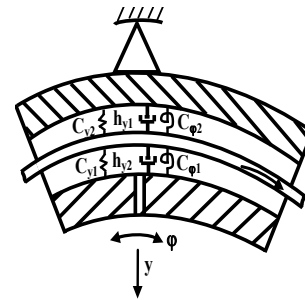

Fig. 10. Dynamic model, when elastic ring is stimulated in the inside of every segment

### Dynamic model of elastic ring that is connected bearing segments

The elastic ring that connects segments improves characteristics of bearing work, but is started up and problems together as such as vibrations of this ring, which is contributed to vibrations of bearing segment.

Vibrations of adaptive hydrodynamic bearings segments are researched in the article [10], but vibrations in the bearing without segments and ring that is connected segments are made (Fig. 11).

Matrix of mass movement applying the second Newtonian law is given by

$$M\ddot{q} + H\dot{q} + Cq = Q, \quad (12)$$

where  $M, H, C$  are the matrixes of mass, elasticity and rigidity;  $q$  are the broad-brush coordinates.

Eq. 12 is described dimensional vibrations of ring by six coordinates in general case. Unidirectional movement of mass in a work regime could evaluate only and therefore outspread Eq. 12 would appeared so

$$\begin{bmatrix} m & 0 \\ 0 & 0 \end{bmatrix} \begin{bmatrix} \ddot{y} \\ 0 \end{bmatrix} + \begin{bmatrix} h_{y1} & 0 \\ 0 & h_{y2} \end{bmatrix} \begin{bmatrix} \dot{y} \\ 0 \end{bmatrix} + \begin{bmatrix} C_{y1} & 0 \\ 0 & C_{y2} \end{bmatrix} \begin{bmatrix} y \\ 0 \end{bmatrix} = \begin{bmatrix} Q \\ 0 \end{bmatrix}, \quad (13)$$

where  $M = \begin{bmatrix} m \\ 0 \end{bmatrix}$ ,  $\ddot{q} = \begin{bmatrix} \ddot{y} \\ 0 \end{bmatrix}$ ,  $H_y = \begin{bmatrix} h_{y1} \\ h_{y2} \end{bmatrix}$ ,  $\dot{q} = \begin{bmatrix} \dot{y} \\ 0 \end{bmatrix}$ ,  $C_y = \begin{bmatrix} C_{y1} \\ C_{y2} \end{bmatrix}$ ,

$q = \begin{bmatrix} y \\ 0 \end{bmatrix}$ ,  $Q = \begin{bmatrix} Q \\ 0 \end{bmatrix}$ .

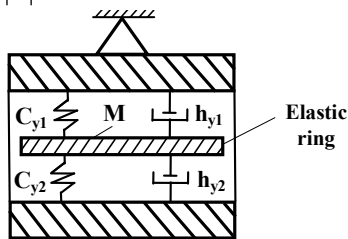

Fig.11. Dynamic model of bearing elastic ring.  $M$ -mass of ring,  $C_{y1}, C_{y2}$  - elasticity,  $h_{y1}, h_{y2}$  -rigidity

### Results and its discussion

The obtained results of adaptive hydrodynamic segmental bearings researches are given (Fig. 12 - 19). Results are given rotor rotating with 2000 and 4000 rotation frequency.

Results of experimental researches (Fig. 12 - 19) demonstrate differences of vibrations of adaptive hydrodynamic bearing with several shoulders (Fig. 12a - 19a) and of adaptive hydrodynamic segmental bearing with ring (Fig. 12b - 19b) that is linked segments.

For the rotor rotating 2000 rpm the difference between horizontal amplitudes of vibrochange signals (Fig. 12a) is  $1,2 \mu\text{m}$  (Fig. 12b). For the rotor rotating 4000 rpm the difference between horizontal amplitudes of vibrochange signals (Fig. 16a) is  $14 \mu\text{m}$  (Fig. 16b). Analogous results are obtained and between signals of vertical changes. For the rotor rotating 2000 rpm the difference between vertical amplitudes of vibrochange signals (Fig. 14a) is  $2,8 \mu\text{m}$  (Fig. 14b). For the rotor rotating 4000 rpm the difference between vertical amplitudes of vibrochange signals (Fig. 18a) is  $18,2 \mu\text{m}$  (Fig. 18b).

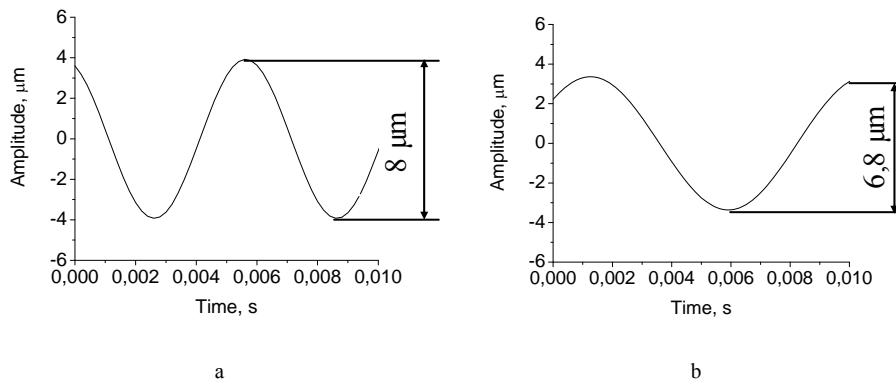

Fig. 12. Adaptive hydrodynamic bearings signal of vibrochange in the horizontal direction, when frequency of rotor rotation approximately is 2000 rpm: a - with several shoulders that are connected segments, b - with elastic ring that is moved easily

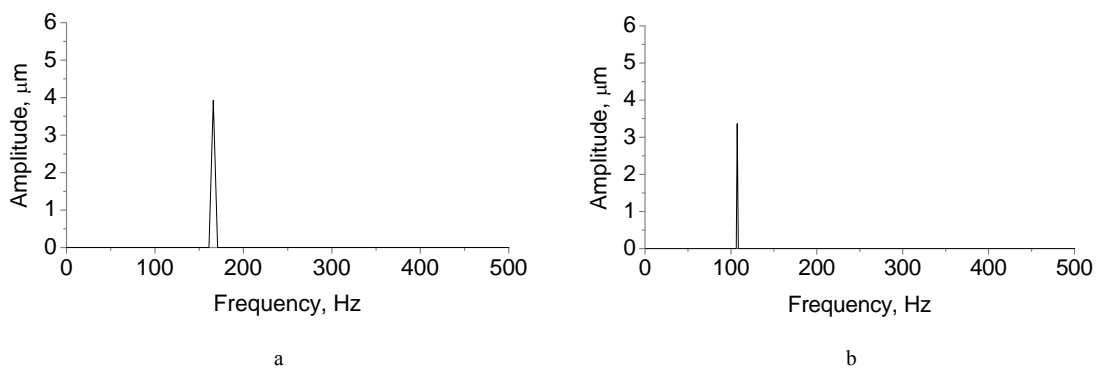

Fig. 13. Adaptive hydrodynamic bearings vibrochange signal of spectrum in the horizontal direction, when frequency of rotor rotation approximately is 2000 rpm: a - with several shoulders that are connected segments, b - with elastic ring that is moved easily

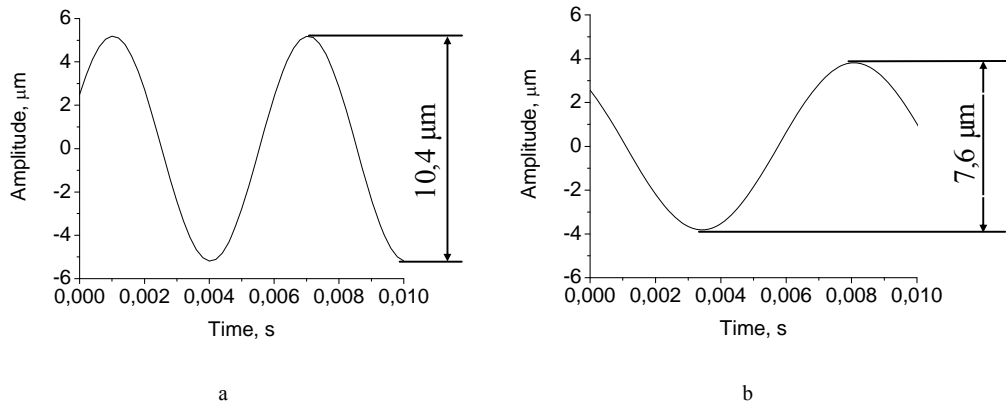

Fig. 14. Adaptive hydrodynamic bearings signal of vibrochange in the vertical direction, when frequency of rotor rotation approximately is 2000 rpm: a - with several shoulders that are connected segments, b - with elastic ring that is moved easily

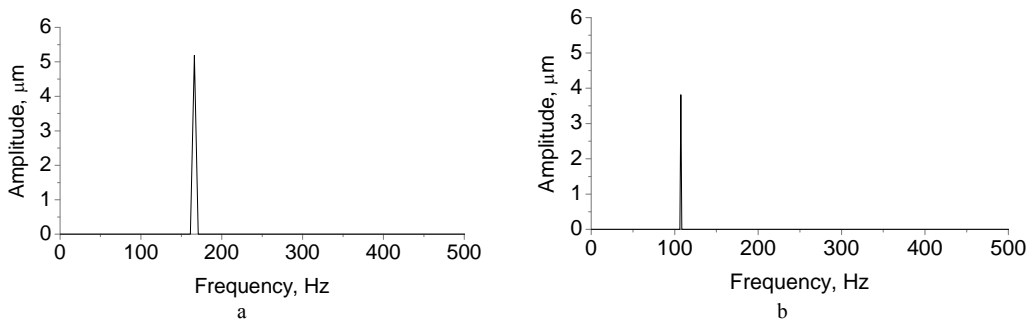

Fig. 15. Adaptive hydrodynamic bearings vibrochange signal of spectrum in the vertical direction, when frequency of rotor rotation approximately is 2000 rpm: a - with several shoulders that are connected segments, with elastic ring that is moved easily

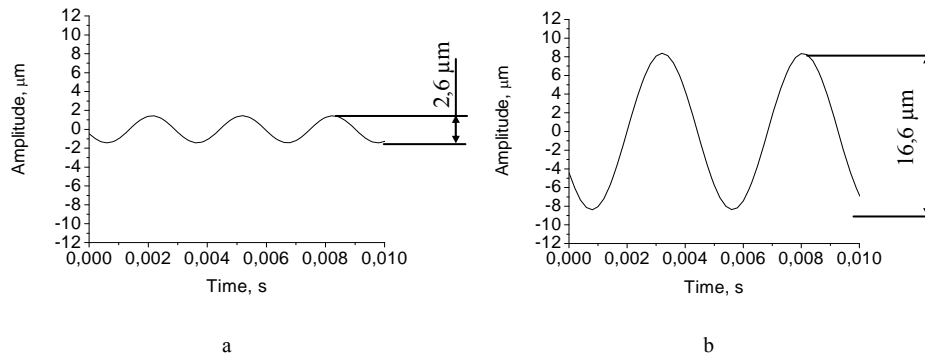

Fig. 16. Adaptive hydrodynamic bearings signal of vibrochange in the horizontal direction, when frequency of rotor rotation approximately is 4000 rpm: a - with several shoulders that are connected segments, b - with elastic ring that is moved easily

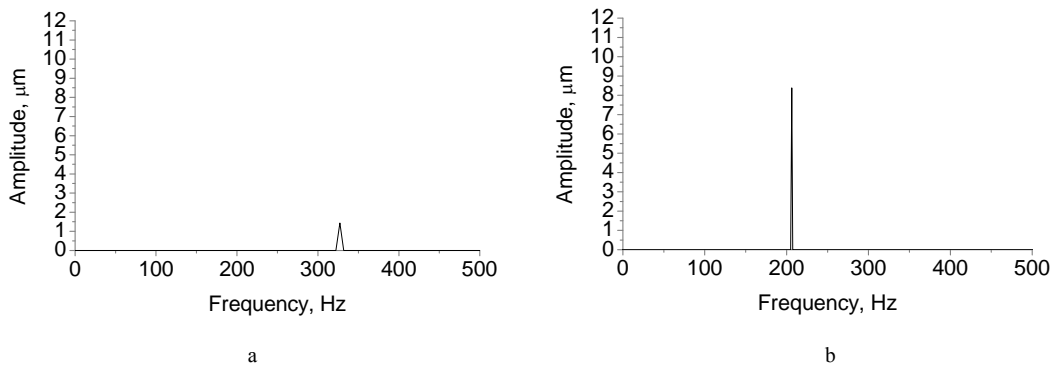

Fig. 17. Adaptive hydrodynamic bearings vibrochange signal of spectrum in the horizontal direction, when frequency of rotor rotation approximately is 4000 rpm: a - with several shoulders that are connected segments, b - with elastic ring that is moved easily

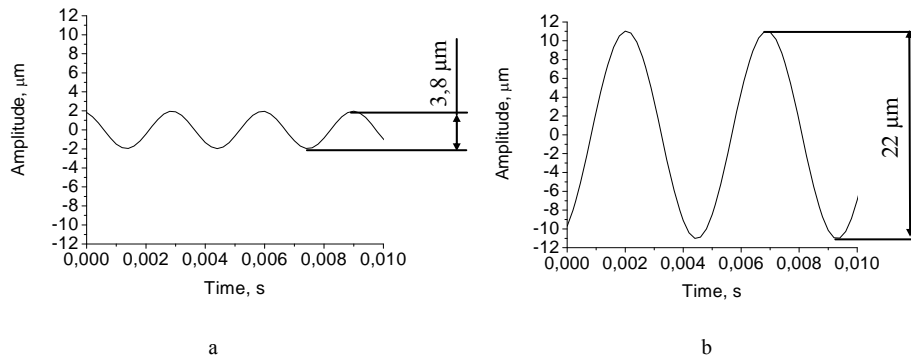

Fig. 18. Adaptive hydrodynamic bearings signal of vibrochange in the vertical direction, when frequency of rotor rotation approximately is 4000 rpm: a - with several shoulders that are connected segments, b - with elastic ring that is moved easily

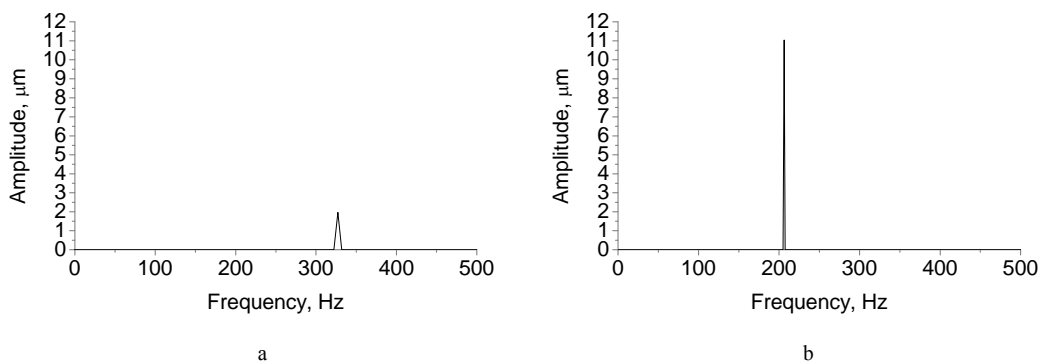

Fig. 19. Adaptive hydrodynamic bearings vibrochange signal of spectrum in the vertical direction, when frequency of rotor rotation approximately is 4000 rpm: a - with several shoulders that are connected segments, b - with elastic ring that is moved easily

The difference between amplitudes of vibrochanges signals spectrums of adaptive hydrodynamic bearings with several shoulders that are connected segments, rotor rotating 2000 rpm and rotor rotating 4000 rpm, is 2 times almost.

The difference between amplitudes of vibrochanges signals spectrums of adaptive hydrodynamic bearings with elastic ring that is connected segments, rotor rotating 2000 rpm and rotor rotating 4000 rpm, is 3 times almost.

The physical models of bearings (Fig. 2a, 3, 6) are very similar, but dynamic and mathematic models are different just us indexes of work of these bearings (Fig. 12 - 19). Knowing correctly indexes of work bearings in a wide range of rotation frequencies only it can choose correctly bearings for particular mechanismus. That shows that parameters of work are differenced being very analogous and constructively not difference systems almost.

Adaptive hydrodynamic segmental bearings with connecting segments elastic ring work more stable than adaptive hydrodynamic segmental bearings with connecting segments several shoulders, this can be seen from the obtained results. That matter is that the frequency of rotor rotation hold sway to work stability of these bearings. It is very important, that system would work, independently from different factors. Outside factors could be different: frequency of rotor rotation, change of temperature and so on.

It is important using dynamic mechanisms, that it could be longevity, could work surely and stably. Unstable work of separate knot disturbs the work of all system. Investigated bearings are used in different mechanismus that work in different conditions and regimes. It is important, that stable work of these bearings would be in a wide range of rotation frequencies.

Resonant frequencies could establish itself vibrations of system. Frequencies of vibrations of the investigated system and other parameters can be found knowing the vibration frequencies of each investigated unit of the whole system.

## Conclusions

Adaptive hydrodynamic segmental bearings with several shoulders connecting segments operate more stable than adaptive hydrodynamic segmental bearings with elastic ring connecting segments, because changes between amplitudes of spectrums are made 2 occasions, when changes of other bearings are made 3 occasions.

Complex research of system only, that is dynamic mathematic modeling and experimental researches are given full information about investigative system, its possible breakdowns, regularities of work and other parameters.

Knowing indexes of work bearings exactly in a wide range of rotation frequencies only could choose bearings for concrete mechanism correctly.

A lot of sources that make vibrations in adaptive hydrodynamic segmental bearing complicate the modeling.

#### References

1. **Barzdaitis V., Činikas G.**: Monitoring and diagnostic of rotor machines. Kaunas, Technology. 1998. P.364.
2. **Vekteris V., Čereška A., Jurevičius M.** Comparable analysis of vibrodiagnostic results of rotary components with different type bearings. Journal of Vibroengineering. 2008 June. Vol. 10. No. 2. P.251-255.
3. **Vekteris V. J.**: Adaptive tribological systems. Theory and application. Scientific publications. Vilnius: Technique. 1996. P. 203.
4. **Vekteris V.** Autoadaptive fluid film bearings. Mechanika. 2000. Vol.26. No. 6. P.57-62.
5. **Lipowsky G., Solyomvari K., Varga G.**: Vibration testing of machines and their maintenance. Amsterdam: Elsevier Science Publishers. 1990. P.303.
6. **Muszynska A.**: Vibrational diagnostics of rotating machinery malfunctions. International Journal of Rotating Machinery. USA. 1995. Vol.1. No. 3-4. P.237-266.
7. **Karnopp D. C., Margolis D. L., Rosenberg R. C.**: System dynamics: A unified Approach, 2-nd ed. USA. John Wiley and Sons, Inc. 1990. P.514.
8. **Bently D. E.** Rotating machinery measurements 101. Orbit, USA 1994. Vol.15. No. 2. P. 4-6.
9. **Vekteris V., Čereška A.** Diagnostics of functioning quality of the systems with sliding bearings. Mechanika. Kaunas: Technology. 2002. No. 2. P. 51-56.
10. **Vekteris V., Čereška A., Jurevičius M.** Diagnostic analysis of similar constructions of adaptive hydrodynamic bearings. Ultragarasas. Kaunas: Technology. 2008. Vol. 63. No. 3. P.47-52.
11. **Barzdaitis V., Činikas G.** Condition monitoring data formats used in rotating machinery diagnostics. Mechanika. Kaunas: Technology. 1997. No. 2. P. 40-48.
12. **Agams M. L., Payondeh S.** Self-excited vibration of statistically unloaded pads in tilting-pad. Journal Bearings. Fournal of Lubrication Technology. 1983. Vol. 105. No 3. P. 64-72.
13. **Bently D. E., Hatch CH. T.**: Fundamentals of rotating machinery diagnostics. Bently Pressurized Bearing Company, printed in Canada, first printing. 2002. P.725.
14. **Čereška A., Vekteris V.** Analytical research of hydrodynamic bearings in mechatronical systems. Solid State Phenomena. Trans tech publications LTD. 2005. Vol. 113. P. 383-387.
15. **Childs D.**: Turbomachinery rotordynamic. Phenomena, Modeling and Analysis. J.Wiley & Sons, Inc. New York. 1993. P.476.
16. **Augustaitis V. K.**: Mechaninių virpesių pagrindai. Vilnius. Žiburio leidykla. 2000. P.319.
17. **Аурусгайтис В. К.** Анализ и синтез колебаний машин к приводу металлорежущих станков. Вильнюс. Техника. 1994. С.308.
18. **Barzdaitis V., Činikas G.** Mechaninių ir mechatroninių sistemų modeliavimas ir tyrimas. KTU: Technologija, Kaunas. 1996. P.29p.
19. **Бекрепис В., Черешка А.** Машиностроение и техносфера XXI века. Сборник трудов. Севостополь, Украина. 2003. Том 1. С.122-126.
20. **Čereška A.** Non-destructive diagnostic of influence of different factors on rotary systems with bearings of sliding. Ultragarasas. Kaunas: Technology. 2006. Vol. 60. No. 3. P.16-19.

A. Čereška, V. Vekteris

#### Adaptyvių hidrodinaminių segmentinių guolių modeliavimas

##### Reziumė

Šiuolaikinėje technikoje yra daug mechaninių virpamųjų sistemų, kurių virpesių tyrimas turi didelę teorinę ir praktinę reikšmę. Tirtant šiuolaikines sistemas atliekamas fizinis, dinaminis ir matematinis modeliavimas.

Straipsnyje nagrinėjami panašių konstrukcijų adaptyvūs hidrodinaminiai segmentiniai guoliai. Pateikta tokio tipo guolių modeliavimo tvarka ir principai, sudaryti dinaminiai ir matematiniai modeliai.

Pateikta spaudai 2010 03 18

DOI: 10.5755/j01.u.65.1.17143