

## Increasing the accuracy of measurement for the small-shift, two-channel ultrasonic echolocation-based distance meter

**A. Petrauskas**

*Prof. K. Baršauskas Ultrasound Institute  
Kaunas University of Technology  
Studentų st. 50, LT-51368 Kaunas, Lithuania  
E-mail: Algimantas.Petrauskas@ktu.lt*

### Abstract

Non-contact film thickness meters are most useful to measure physical-mechanical properties of thin polymer-based films. When polymerizing PVC resin at high temperature, the environment becomes very turbulent and is a source for measurement errors. This article explores the measurement errors, which arise when using an echolocation-based distance meter in such environments. Sources of measurement errors are identified and solutions for elimination of these errors are presented. This article provides the solution to avoid the effects of the turbulent environment on measurement accuracy. Additionally, design guidelines for acoustic distance measurement equipment are presented, along with schematic block diagrams. The equipment is designed for maximum measurement accuracy. When acoustic measurements have to be done in a turbulent environment, a version of the electro-acoustic part of the distance meter is presented. It eliminates the negative effects of the turbulent environment on measurement results, therefore very accurate acoustic measurements of small distances become possible.

**Keywords:** PVC film, polymerization, thickness of film, electro-acoustic distance meter, echolocation, ultrasound, measurement errors, measurement accuracy, piezoelectric transducer, turbulent environment

### Introduction

In practice, most common PVC-based materials are produced by polymerizing PVC resin at high temperatures (around 220 °C). Polymerized films are mechanically joined with various reinforcing materials. The thickness and structure of polymerized films depend on various additives placed in the PVC resin before polymerization. For practical applications, it is important to know the variations in thickness and porosity of the film during and after the polymerization process.

When measuring the thickness and porosity of such films, non-contact thickness (distance) meters are most useful. In the range of non-contact meters, ultrasonic echolocation-based meters have their niche [1, 2].

### Overview of measurement error sources

Acoustic (ultrasonic) echolocation-based meters are widely applied for various distance measurements [1-11]. The operating principle of such meters is based on measuring the duration of measurement signal's propagation to the object and back. Many of such meters use pulse – echo signals.

When measuring in a broad temperature range, measurement errors, which occur due to the dependence of acoustic measurement signal's velocity on temperature [12], need to be determined and compensated.

The error of measured distance (thickness) in this case is determined by changes of ultrasound velocity due to variations in the temperature of the environment (~0.17 % for a change of one degree in temperature). This measurement error can be compensated by applying parametric thermo-compensation [13], which reduces this measurement error down to 0.01 % for a change of one degree in temperature.

The measurement error also depends on the design of the electro-acoustic measurement channel.

When measuring the thickness of PVC films during the polymerization process, turbulent air currents develop in the temperature range of 10... 230 °C. The currents rise towards the measurement sensors and change the path of acoustic measurement signals. Simultaneously, variations occur in the velocity of measurement signals. Additionally, due to temperature gradients in the turbulent environment, acoustic wave refraction and reflection take place. Because of this, the amplitude of the measurement signal varies and, at some moments of the measurement process, cannot even be registered in the transducer.

Chemical composition of air is changing in the process of PVC polymerization. This also has a negative effect on the accuracy of measurements.

The accuracy of measurements also depends on the design of an electro-acoustic system. The measurement error mostly depends on the thermal expansion of the constructive elements and on parasitic signal propagation through constructive elements from a transmitter directly to a receiver, instead of the signal's required path through air to the surface of measurement object and back.

To avoid the influence of the turbulent environment on measurement results, we suggest to separate the environment of the measurement signal's path from the turbulent environment around the object.

When analyzing the influence of a particular echolocation-based meter on the measurement accuracy, choice of a measurement system (layout) is important. The measurement system can be with two electro-acoustic sensors (Fig. 1), one of which transmits and the other receives the measurement signals.

The other option is to use a single transducer that transmits and receives measurement signals. When the

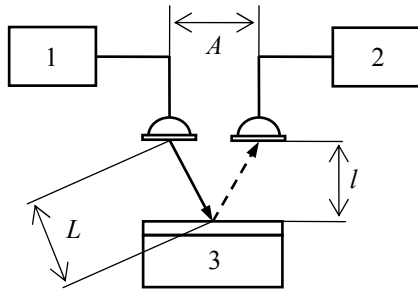

Fig.1. Measurement system with two electro-acoustic sensors: 1 – transmission block of measurement signals; 2 – reception and processing block; 3 – measurement sample

distance  $L$  (Fig. 1) changes in the process of measurement, the distance to the object  $l$  is calculated by the measurement system using expression [13]:

$$l = \sqrt{L^2 - \left(\frac{A}{2}\right)^2} \quad (1)$$

Using Eq. 1, the actual distance  $l$  is calculated using the measured distance  $L$ . One can see from Eq. 1 that by decreasing the distance between transducers  $A$ , the systematic measurement error also decreases. For example, if  $A = 10$  mm, and the measured distance changes by 1 mm, the measurement error is 0.11 mm. Therefore, the distance  $A$  should be as minimal as possible.

In a measurement system option with one transducer, the distance  $A$  is zero and such measurement error is no longer present.

Other source of measurement errors is from the chosen electronic measurement structure in which the measured propagation time errors of the measurement signal occur due to the insufficient signal-to-noise ratio [1, 14-17]. Additionally, the measurement errors occur due to various electronic signal delays in the circuits [18-26].

### Design guidelines for measurement equipment

The measurement signals obtained from separate measurement channels, can be processed in the measurement device simultaneously or consecutively [13]. To decrease the processing time of measurement signals, simultaneous processing of information is preferred.

To decrease the measured propagation time errors of the measurement signal, measurements in all measurement channels need to be made simultaneously. The simplest block diagram of such measurement device is presented in Fig. 2 [13].

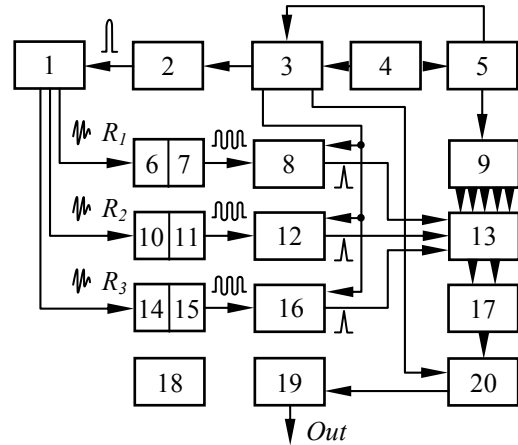

Fig.2. Block diagram of measurement device: 1 – electro-acoustic measurement system; 2 – signal transmission block; 3 – control pulse generator; 4 – master pulse generator; 5 – pulse distributor; 6, 10, 14 – signal reception units; 7, 11, 15 – signal amplitude limiters; 8, 12, 16 – normalizing units; 9 – counter with unitary code; 13 – pulse distributor; 17 – time-interval forming unit; 18 – power source; 19 – current amplifier; 20 – time-interval integrator

In Fig. 3 we present a block diagram of a two-channel measurement device [28], consisting of available electronic components.

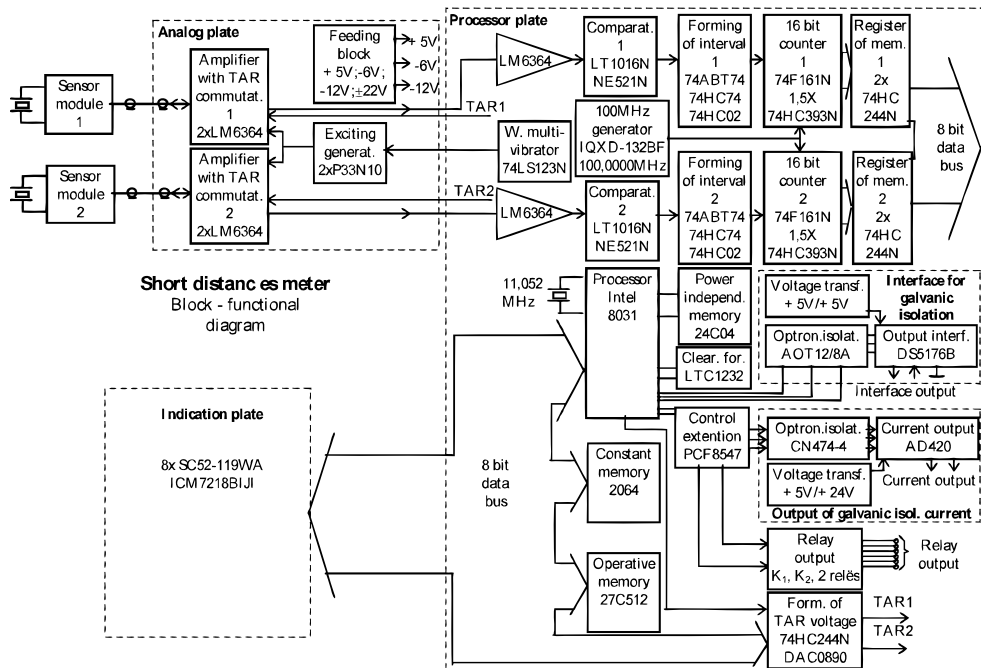

Fig.3. Block diagram of a two-channel thickness measurement device

The second measurement channel of the meter is used as a calibrated channel for determining the exact velocity of sound. The sensor frequency is in the 0.8... 2 MHz range. The transmitters are excited by one half-period electric pulse. The detection circuit for determining zero crossing is used in the receiving channel of measurement signals. This way the obtained measurement accuracy is the same as of the phase method [28]. The obtained time interval, proportional to the measured distance, is filled by 100 MHz marks. These marks are counted by a counter and processed by the processor. The processor performs the primary processing of the measurement information (eliminating the changes of ultrasound velocity, calculating average results, etc.).

The meter may be connected to the PC through the interface RS485. The meter also has an LCD panel showing two rows of four-figure results. The absolute measurement error is 0.02 mm. The error arises because of the delays and noises in the electronic circuits and due to the instability of the threshold level of the electronic comparator [28]. Therefore, the measured signal delay time fluctuates. This instability was reduced by averaging the results of measurement. The errors arising due to changes in temperature, composition, humidity and air pressure in the acoustic measurement channel were eliminated by using additional calibrated length channel for determination of the exact sound velocity. The number of measurement channels can be increased as needed.

A possible version of the electro-acoustic part of the thickness meter is schematically presented in Fig. 4 [29].

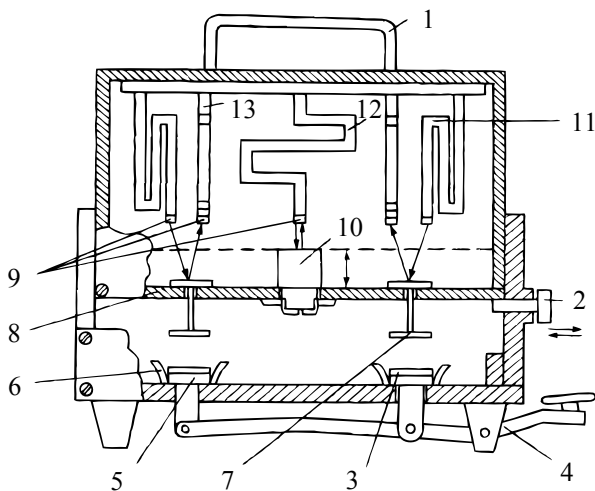

Fig.4. Electro-acoustic part of the thickness meter

The environment of the measurement signal's path is separated from the turbulent environment around the object. This makes it possible to avoid the influence of turbulent air streams and changes in a chemical gas composition on the measurement results.

The measurement equipment is presented in Fig. 4 operates as follows:

By using the handle (1), the upper measurement chamber is raised and secured using the spring retainer (2). This enables the sample (3) for evaluation to be swapped. By using the lever (4), measurement tables (5) are raised with respect to the nest (6). This enables to swap samples. When the retainer (2) is removed, the upper measurement

chamber is lowered to the measurement position. The thickness transferors (7) land on the surface of the sample. Their weight is just 0.1 gram and the surface area is 4 cm<sup>2</sup>. The pressure on the sample is very low and has no effect on its physical-mechanical properties. When the samples are subjected to high temperature, their polymerized starts. The sample structure becomes porous and the thickness transferor rises to a certain height. This height depends on the composition of the PVC resin and on the temperature of polymerization. During the polymerization process, heat and gas are produced in the sample due to exothermal reaction. The thickness transferors transfer the thickness of the measurement sample to the measurement chamber (8). By transferring the thickness to the measurement chamber, the influence of turbulent temperature streams on the accuracy of measurement is eliminated. Piezoelectric transducers (9) are operating in the transmission-reception mode of measurement signals. The calibrated length channel (10) provides a time interval, required to eliminate the influence of variations in sound velocity on measurement results. The design of the upper chamber has a uniform measurement environment, required for precise acoustic measurements. In this environment measurement and calibrated length channels are installed. The holders of the piezoelectric sensors (11, 12, 13) have this irregular bracket shape to compensate the effects of a linear thermal expansion. This design of the electro-acoustic system provides ability to swap samples quickly and avoids the effects of temperature on measurement results.

## Conclusions

To measure accurately small distances using an echolocation-based distance meter, the measurement environment has to be controlled, because it is the main source of measurement errors.

To avoid the influence of a turbulent environment on measurement results, the environment of the measurement signal's path must be separated from the turbulent environment around the object.

## References

1. **Lynnworth L. C.** Ultrasonic measurement for process control. Academic Press Inc. ISBN 0-12-460585-0. 1989.
2. **Miniailga V., Petrauskas A., Razutis P.** Results of measurement of liquid absorption in porous materials by ultrasonic method. ISSN 1392 – 2114. Ultragarsas (Ultrasound). Kaunas: Technologija. 2000. Nr 1(34). P. 31-33.
3. **Magori V.** Signal processing for smart ultrasonic sensors. Proc. 3rd Annual European Computer Conference 1989. Nr. 3. P. 21-26.
4. **Rencken W. D.** Autonomous low-cost mobile robots for complex non-production environments, 1st IFAC Internat. Workshop on Intelligent Autonomous Vehicles, Univ. of Southampton, U.K. 1993. P. 897-916.
5. **Kleinschmidt P., Magori V.** US robotic-sensors for exact short range distance measurement and object identification. Proc. IEEE Ultrasonics Symp. 1985. P. 457-462.
6. **Bernst T., Loschberger J., Magori V.** Moderne vefahren der signalverarbeitung bei ultraschall-robotik-sensoren. NTG-Fachberichte 93. 1986. P. 1171.
7. **Loschberger J., Magori V.** Ultrasonic robotic sensors with lateral resolution, IEEE Ultrasonics Symposium. 1988. P. 547.

8. **Vossiek M.** Intelligente sensorsignalverarbeitung durch kombination von Fuzzy-logik mit klassischer signalvorverarbeitung am beispiel eines luftultraschallsystems zur platinenbestueckungskontrolle. VDE-Fachtagung Techn. Anwendung Fuzzy-Systemen. Dortmund. 1992. P. 71-80.
9. **Kleinschmidt P., Magori V.** Ultrasonic remote sensors for noncontact object detection. Siemens Forschungs- und Entwicklungsberichte 10. 1981. P. 110-118.
10. **Yano T., Tone M., Fukumoto A.** Range finding and surface characterization using high-frequency air transducers. IEEE Trans. UFFC. 1987. P. 232.
11. **Grandia W. A., Fortunko C. M.** NDE applications of air-coupled ultrasonic transducers. IEEE Ultrasonic Symposium, Proceedings. ISSN 1051-0117. 1995. Vol. 1. P. 697-709.
12. **Горбатов А. Рудашевский Г.** Акустические методы измерения расстояний и управления (in Russian). Moscow: Energoizdat. 1981. P.21-44. P142-174.
13. **Петраускас А., Раманаускас И., Савицкас В.** Ультразвуковой измеритель малых изменений расстояния (in Russian). ISSN 636-6367. Вильнюс: Минтис. Ультразвук (Ultrasound). 1983. No. 15. P. 93-97.
14. **Dumbrava V., Svilainis L.** Ultragarasinio keitiklio pradinio stiprintuvo triukšminis modelis (in Lithuanian). Elektronika ir elektrotechnika. Kaunas: Technologija. 2006. No. 2(66). P. 21-25.
15. **Svilainis L., Puodžiunas V.** Ultrasonic NDE system: the hardware concept. Ultragarsas. Kaunas: Technologija. 1998. No. 29. P. 34-40.
16. **Turo A., Salazar J., Chavez J. A., Kichou H. B., Gomez T. E., Montero de Espinoza F., Garcia – Hernandez M. J.** Ultra-low noise front-end electronics for air-coupled ultrasonic non-destructive evaluation. NDT&E International. 2003. P. 93-100.
17. **Yanez Y., Garcia – Hernandez M. J., Salazar J., Turo A., Chavez J. A.** Designing amplifiers with very low output noise for high impedance piezoelectric transducers. NDT&E International. 2005. P. 491-496.
18. **Álvarez F. J., Ureña J., Mazo M., Hernández A., García J. J., De Marziani C.** High reliability outdoor sonar prototype based on efficient signal coding. IEEE Trans. Ultrason. Ferroelectr. Freq. Control. 2006. No. 53. P.1863-1870.
19. **Benet G., Martínez M., Blanes F., Pérez P., Simó J. E.** Differentiating walls from corners using the amplitude of ultrasonic echoes. Robot. Auton. Syst. 2005. Nr. 50. P.13-25.
20. **Parrilla M., Anaya J. J., Fritsch C.** Digital signal processing techniques for high accuracy ultrasonic range measurements, IEEE Trans. Instrum. Meas. 1991. Vol. 40. No. 4. P. 759-763.
21. **Manthey W., Kroemer N., Magori V.** Ultrasonic transducers and transducer arrays for applications in air. Meas. Sci. Technol. 1992. Vol. 3. No. 3. P. 249-261.
22. **Carullo A., Parvis M.** An ultrasonic sensor for distance measurement in automotive applications. IEEE Trans. Instrum. Meas. 2001. Vol. 1. Nr. 2. P. 143-147.
23. **Mitri F. G. Kinnick R. R. Greenleaf J. F. Fatemi M.** Continuous-wave ultrasound reflectometry for surface roughness imaging applications. Ultrasonics. 2009. No. 49(1). P. 10-14.
24. **Gómez-Ullate Y., De Espinosa F. M.** Ultrasonic air-coupled metrology of material surfaces. Proceedings IEEE Ultrasonics Symposium. 2004. Vol.3. P. 2298-2301.
25. **Gan T. H., Hutchins D. A., Billson D. R., Schindel D. W.** High resolution air-coupled ultrasonic imaging of thin materials. IEEE-UFFC. 2003. Nr. 50. P. 1516-1524.
26. **Gan T. H., Hutchins D. A., Billson D. R., Schindel D. W.** The use of broadband acoustic transducers and pulse compression techniques for air-coupled ultrasonic imaging. Ultrasonics. 2001. Nr. 39(3) P.181-194.
27. **Robertson T. J., Hutchins D. A., Billson D. R., Rakels J. H., Schindel D. W.** Surface metrology using reflected ultrasonic signals in air. Ultrasonics. 2001. No. 39(3). P.479-486.
28. **Petrauskas A., Razutis P.** Investigation of echolocational ultrasonic methods by increasing accuracy in level measurements. ISSN 1392-2114. Ultragarsas (Ultrasound). Kaunas: Technologija. 2001. No.4(41). P. 18-21.
29. **Шидлаускас С., Петраускас А., Савицкас В.** Ультразвуковой двухканальный измеритель малых перемещений (in Russian). ISSN 0369-6367. Вильнюс: Минтис. Ультразвук (Ultrasound). 1988. No. 20. P. 131-134.

A. Petrauskas

**Dvikanalio aidolokacinio mažų atstumų matuoklio matavimo tikslumo padidinimas**

Reziumė

Bekontakčiais atstumo matuokliais galima matuoti įvairių plėvelių storį matavimams polimerizacijos procesu metu. Matuojant PVC dervos pagrindu sudarytų plėvelių storį, jų polimerizacijos metu aukštoje temperatūroje susidaro turbulentiniai srautai, kurie turi įtakos storio matavimo paklaidoms. Šiame straipsnyje aprašoma, kaip galima būtų sumažinti paklaidas taikant bekontaktį aidolokacinį akustinį atstumo matavimo būdą. Apžvelgiami matavimo paklaidų atsiradimo šaltiniai ir būdai jiems eliminuoti. Pateikiama elektroakustinės sistemos konstrukcija, leidžianti išvengti kylančių turbulentinių srautų įtakos matavimų rezultatams.

Pateikta spaudai 2010 06 08

DOI: 10.5755/j01.u.65.2.17145