

Investigations of the inspection possibilities of the inner surface of the nozzle using ultrasonic phased array

E. Jasiūnienė, L. Mažeika, O. Tumšys

*Ultrasound Institute, Kaunas University of Technology,
Studentu 50, LT-51368 Kaunas, Lithuania*

Abstract

The objective of this work was to investigate the inspection possibilities of the inner surface of the nozzle using ultrasonic linear phased array. The task was to determine ranges of angles and positions, which would enable to cover completely the areas necessary to inspect. The propagation of the ultrasonic wave in the nozzle has been modelled using CIVA software. The modelled ultrasonic field at different positions on the nozzle and at different steering angles of ultrasonic phased array are presented.

The presented results demonstrate possible positions of ultrasonic phased array for the inspection of the inner curved surface of the nozzle.

Keywords: nozzle, ultrasonic NDT, phased array, CIVA

1. Introduction

Ultrasonic non-destructive testing (NDT) methods are widely used for testing of various pipes. These methods allow determining pipe defects location, orientation and size. Greater problems arise in ultrasonic inspection of nozzles. The specific geometry of the nozzle due to connection of two cylindrical bodies gives the complex shape of volumes and surfaces. The particular geometry of nozzles has led to the development of specific ultrasonic inspection techniques [1-7].

Nowadays theoretical simulation of the ultrasonic signal propagation and reflection in the objects under investigation plays an important role in an increasing range of NDT applications. Simulation demonstrates the performance of the different ultrasonic methods at a relatively low cost. To achieve this aim many different modelling techniques (finite elements, finite difference, etc.) are used. CIVA software is used to design the arrangement of ultrasonic transducers and to evaluate their ability to detect defects. Modelling of the wave propagation in CIVA is based on an integral formulation of the radiated field. The software inputs are the geometry

and the characteristics of the object to be inspected. Within the CIVA software a set of tools specifically developed for 2D and 3D signal simulations and the phased array applications are included [8-11].

The general objective of this work was to find the parameters, best positions and scanning ranges of the ultrasonic phased array capable to detect the defects in the inner surface of the nozzle.

2. The geometry of the nozzle to be inspected

The nozzle under investigation is the junction of the 300mm diameter feedwater pipe with a cylindrical wall of reactor vessel. For modelling of the inspection of the nozzle the CIVA software was used. It enables to create 3D models of the nozzles. The 3D model of the nozzle under investigation created using the CIVA software is presented in Fig.1. The zone to be inspected is the inner curved surface of the nozzle (Fig.2). The possible positions of ultrasonic phased array from which the inner surface can be inspected are shown in Fig.2.

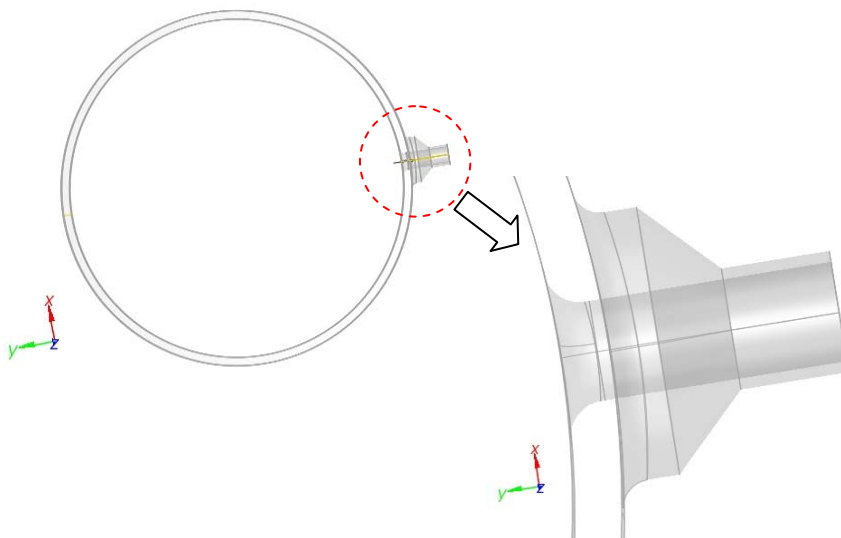

Fig.1. General geometry of the nozzle to be inspected

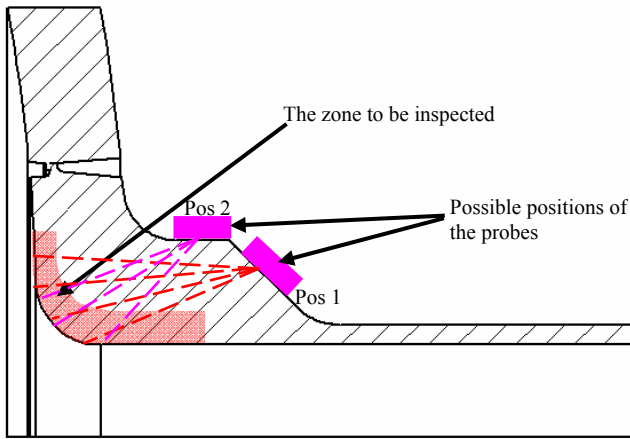

Fig.2. The cross section of the nozzle to be inspected and the possible positions of the ultrasonic probes

Defects in the inner surface zone can be caused by erosion. The erosion type defects with wider width of the tip can be detected from several positions (Fig.2). At the first position (position 1 in Fig.2) there is the 45° slope between the relatively thin wall of the pipe and thick wall of the nozzle. However, thin cracks will be not detectable from this position. The open to the surface cracks could be detected by a corner reflection. The corner in this case is created by the inner surface of the wall and the crack itself. However, the ultrasonic beam should be oriented perpendicularly to the corner axis. The positions suitable for detection of cracks oriented perpendicularly to generatrix of the inner surface of the nozzle are on the outer surface of the nozzle (position 2 in Fig.2). So, the modelling task is to determine which positions and what ranges of steering angle of the phased array would enable the complete coverage of the areas necessary to inspect.

3. The ultrasonic phased array, used for the modelling

In order to solve the above defined tasks the different positions of the ultrasonic phased array for testing of the inner surface of the nozzle using the CIVA software were investigated. The parameters of the phased array were selected similar to the parameters of a conventional phased arrays used for NDT.

The geometry and the parameters of the investigated phased array are presented in Fig. 3. It is a linear phased array consisting of the 32 elements. The central frequency of the elements is 2 MHz. The width of the elements is 0.53 mm, the gap between elements - 0.25 mm, the active aperture – 24.71 mm, the passive aperture – 25 mm.

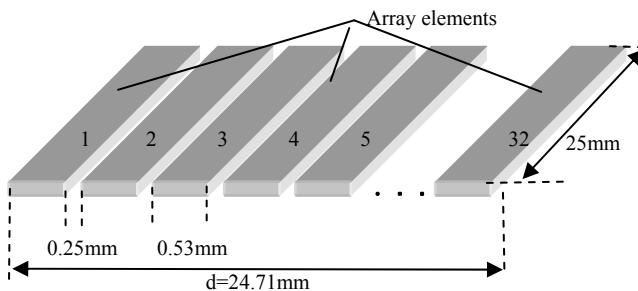

Fig.3. Geometry and arrangement of the elements in 1D linear array

The parameters of the wedge used for modelling are given in Fig. 4: the wedge angle $\alpha=34.4^\circ$, the height at the position of the first element $a_2=3,01$ mm, the length of the inclined zone corresponds to the active aperture and is $d=24,71$ mm.

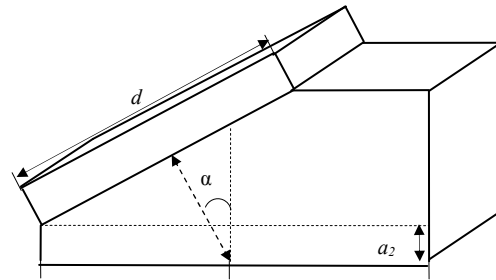

Fig.4. Wedge geometry

The transducer was excited using 2 MHz signal with 65% bandwidth. The waveform of the excitation signal is shown in Fig. 5. The sampling frequency was 50 MHz.

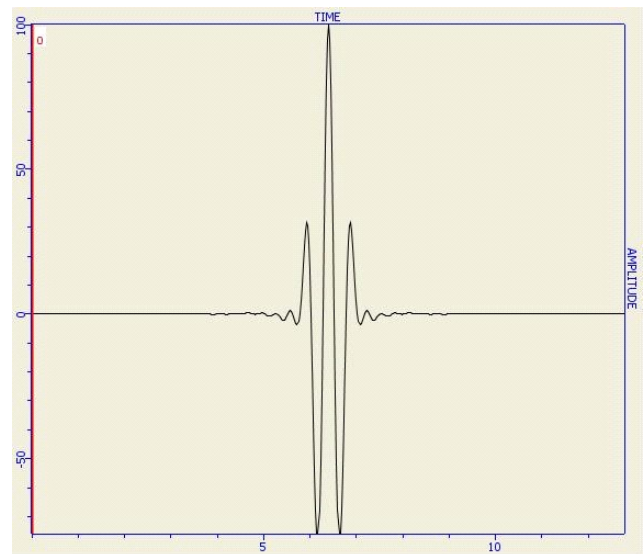

Fig.5. Waveform of the excitation signal

4. Investigations of the inspection possibilities of the inner surface of the nozzle

During modelling it was assumed, that the nozzle material is steel. The velocity of longitudinal waves in the test object is 5900 m/s, the velocity of shear waves is 3192 m/s and density - $\rho=7.8$ g/cm³. First of all computations of ultrasonic field coverage of the nozzle zone to be inspected (inner surface) were performed. Positioning of the probe on the sample and calculated angles of the phased array are shown in Fig.6. The phased array was used in sectorial scanning mode. The beam was scanned from 35° to 70° degrees with a step of 5 degrees. The cumulated image of the ultrasonic field overlaid on the nozzle under investigation is presented in Fig.7.

The samples of the fields at 35°, 40°, 45°, 50°, 55°, 60° superimposed on the nozzle sample in order to have better presentation of the coverage of the zone of interest are shown in Fig.8.

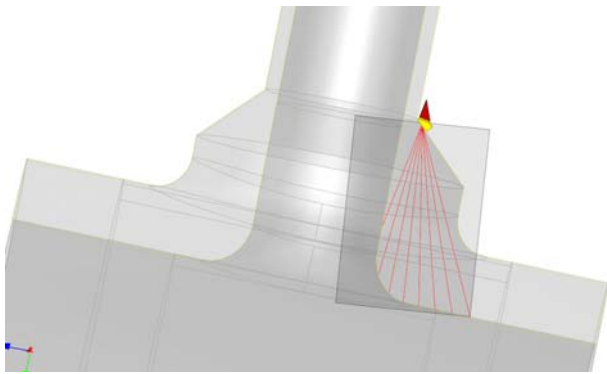

Fig.6. Positioning of the probe on the secondary cylinder and ultrasonic field computation zone (from 35° to 70°)

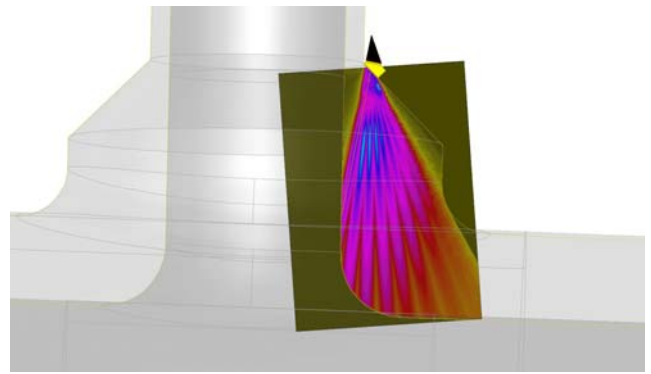
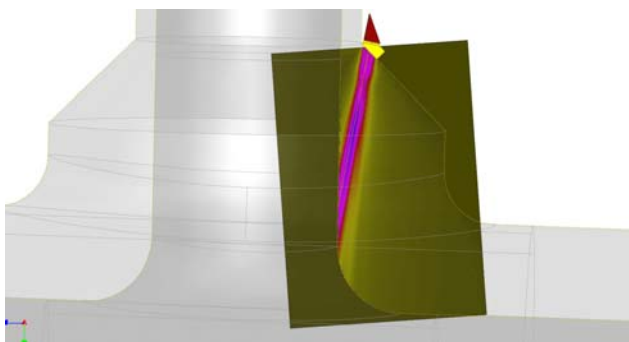
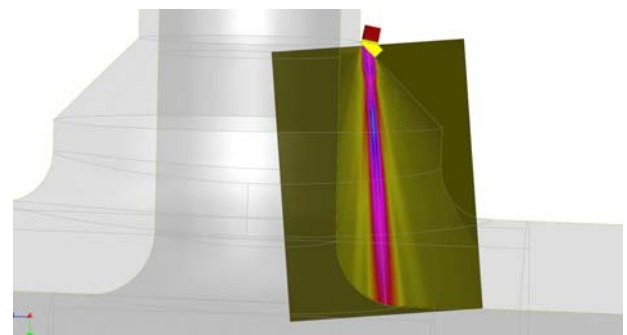

Fig.7. The cumulated image of the ultrasonic field of 2MHz phased array scanned from 35° to 70° degrees



a – 35°



d – 50°

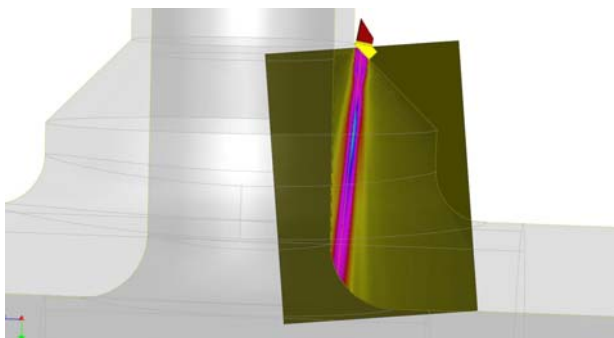

b – 40°

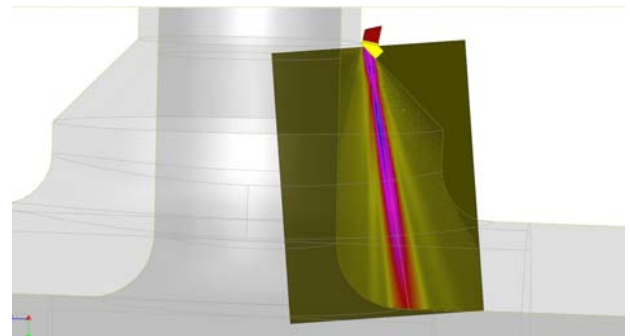

e – 55°

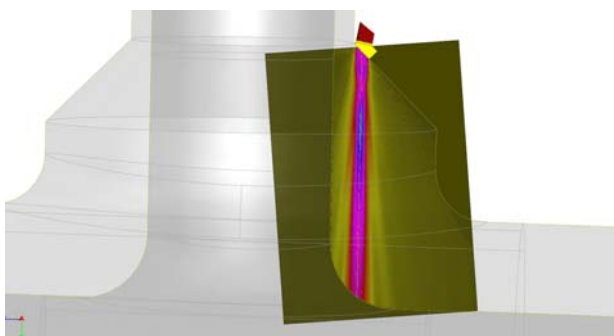

c – 45°

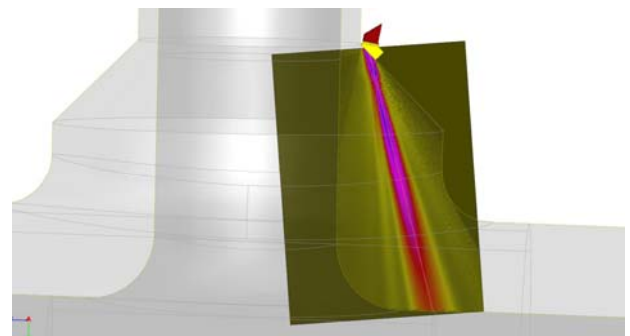

f – 60°

Fig.8. Ultrasonic field of 2MHz phased array superimposed on the nozzle at different angles: a – 35°; b – 40°; c – 45°; d – 50°; e – 55°; f – 60°

The fields at 65° and 70° are not shown, because, as can be seen from the Fig. 6, the field, generated by the array at these angles will be already outside the zone of interest (inner surface region). As can be seen from the images presented, the zone of interest can be covered by the angular scanning of a phased array situated at single

position. However, from this position only volumetric defects and planar cracks oriented perpendicularly to generatrix of the inner surface of the nozzle can be detected. Moreover, the defects close to the inner surface of the vessel are inspected at a relatively small angle.

The inspection of the inner surface of the nozzle is possible also from the curved outer surface of the nozzle (Fig.9). In order to investigate such a possibility the modelling was carried out using the same phased array operating in a sectorial scanning mode. The beam was scanned from 35° to 75° degrees with the step of 5° . The cumulated image of the ultrasonic field is presented in Fig.10.

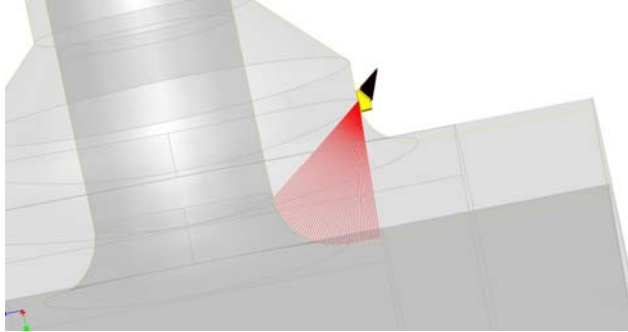

Fig.9. Positioning of the probe on the outer surface of the nozzle (steering angles from 35° to 75°)

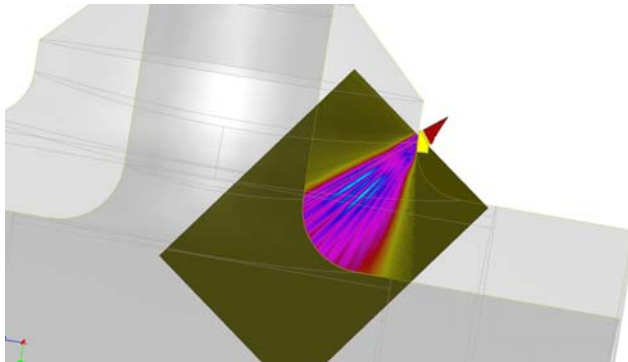
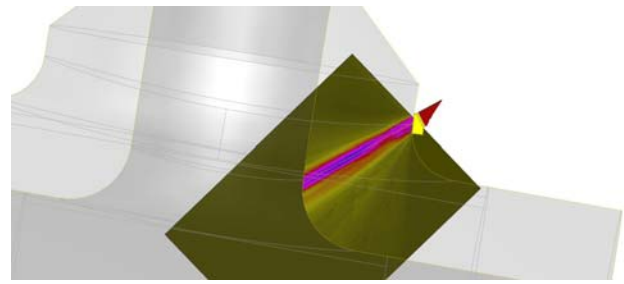

Fig.10. The cumulated image of the ultrasonic field of 2MHz phased array scanned from 35° to 75° degrees

The samples of the fields at 35° , 40° , 50° , 60° and 75° , superimposed on the nozzle sample, in order to have better idea of the coverage of the inner surface with ultrasonic phased array, are presented in Fig.11. The remarks related to the inspection from this position in general are similar to the case analysed above - only volumetric defects and planar cracks oriented perpendicularly to generatrix of the inner surface of the nozzle can be detected. However this position is not as good as the previous with respect to the detection of cracks discussed above because the ultrasonic beam in the case of angles 60° - 75° will be parallel to the radial cracks. So, the crack perpendicular to the surface will be invisible.

Most important feature of techniques analysed above is the fact that in the both cases the cracks with axial or radial orientation will be undetectable, because they are oriented along the ultrasonic beam. The conventional inspection (not TOFD) can not be based on the tip reflection – these reflections are too small and unreliable. The detection of surface breaking cracks should be based on the corner reflection. The “corner” is created by the crack and the inner surface of the nozzle. In order to detect the “corner”, the transducers should be oriented precisely in two planes and perpendicularly to the axis of the “corner” (Fig.12).



a – 35° ;

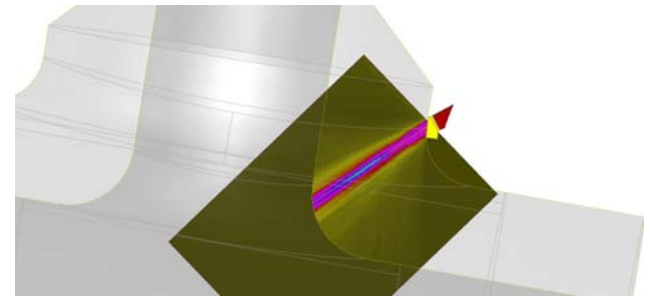

b – 40° ;

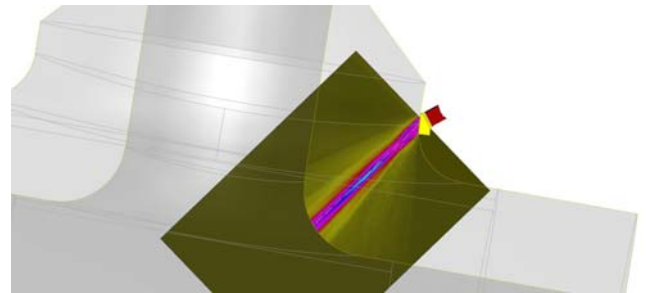

c – 50° ;

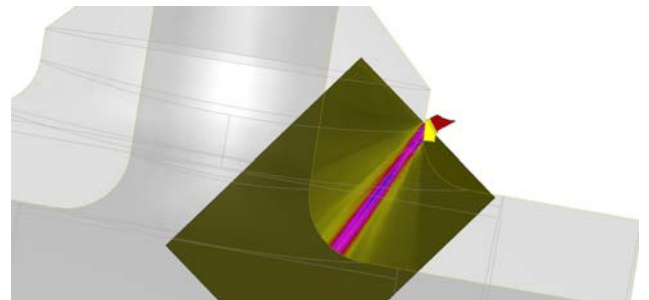

d – 60° ;

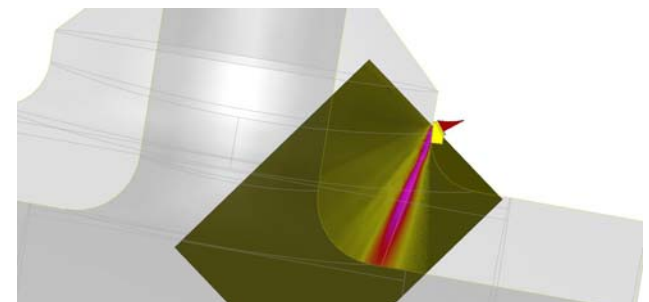

e – 75° .

Fig.11. Ultrasonic field of 2MHz phased array superimposed on the nozzle sample at different angles: a – 35° ; b – 40° ; c – 50° ; d – 60° ; e – 75°

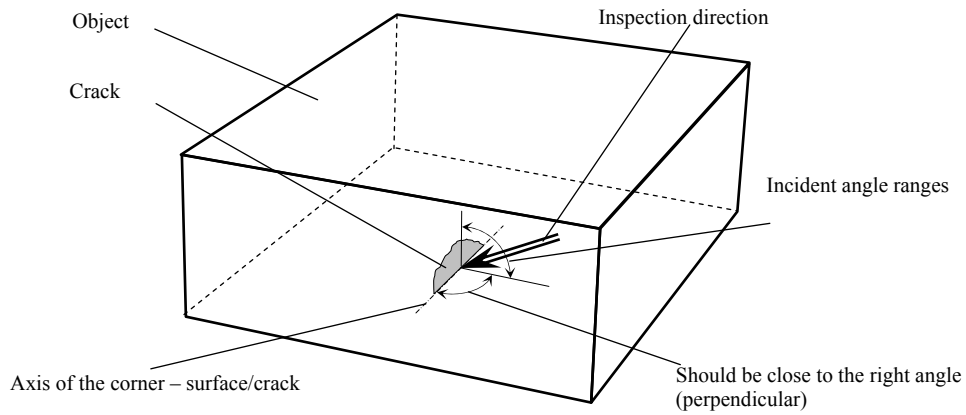

Fig.12. Explanation of the orientation of the probe in order to detect surface braking cracks

In the case of the objects with a complicated geometry this task is not simple - the solution even not always exists. In the case of the cracks in the inner surface of nozzle with axial orientation they are in the plane which goes through the axis of the nozzle. So, the axis of the corner reflection created by such crack always coincides with the generatrix of the inner surface of the nozzle. In this complicated case it is better to analyse the possible positions of the probe in two projections of the nozzle: side and axial. The side view of the nozzle with a possible position of the probe is presented in Fig.13. As can be seen from the side view the beam is not perpendicular to the generatrix. Even more - the axial view shows that the ultrasonic beam does not “touch” the inner surface (Fig.14). For better understanding the calculated ultrasonic fields (at 35°-75° steering angles) generated at this position are shown in axial view (Fig.14) and at two different projections (Fig.15). The presented results demonstrate that the analysed position is not suitable for inspection of the inner surface in the case of axial cracks.

Other possible positions of the ultrasonic phased array are on the outer surface of the nozzle (Fig.16). From the side view it can be seen that at least in some of the positions the transmitted ultrasonic beam can be perpendicular to the generatrix of the inner surface of the nozzle. However, the calculated ultrasonic fields in the

angle ranges 35°-75° at the position 1 (Fig.16) show that the ultrasonic beam of shear waves does not touch the inner surface of the nozzle in this case also (Fig.17). It is possible to steer the phased array in smaller angle ranges – 25°-35°, but at these angles the given phased array does not generate shear waves efficiently (Fig.18).

5. Conclusions

The modelling carried out demonstrated that the positions and parameters of the inspection depend on the type and orientation of the defect. It was shown that in principle the biggest part of the inner surface zone can be inspected. However, some of the positions are complicated for inspection and can require several techniques to be exploited in order to detect the surface breaking cracks.

Acknowledgements

The part of this work was sponsored by the European Union under the Framework-7 project “Autonomous Robot for Automated Inspection of Nozzle Welds“ (Nozzleinspect). The Project is coordinated and managed by TWI (UK).

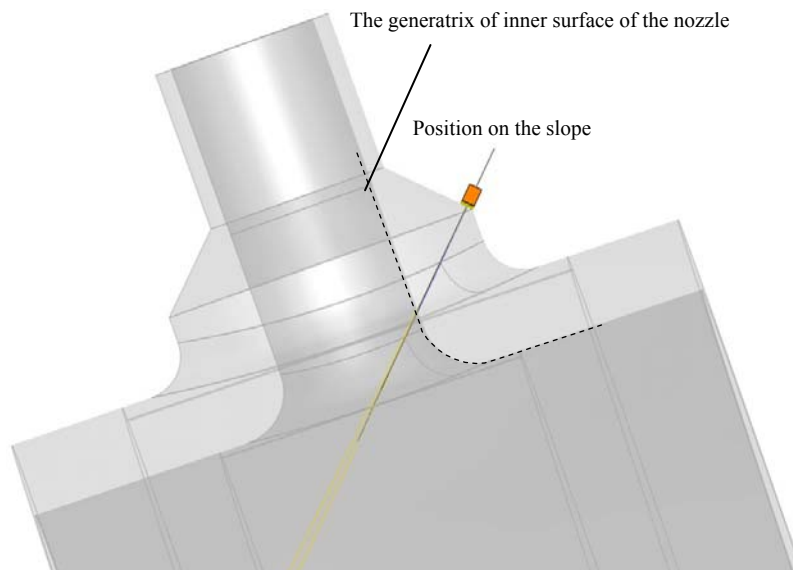

Fig.13. Side view of the nozzle with the possible position of ultrasonic probe

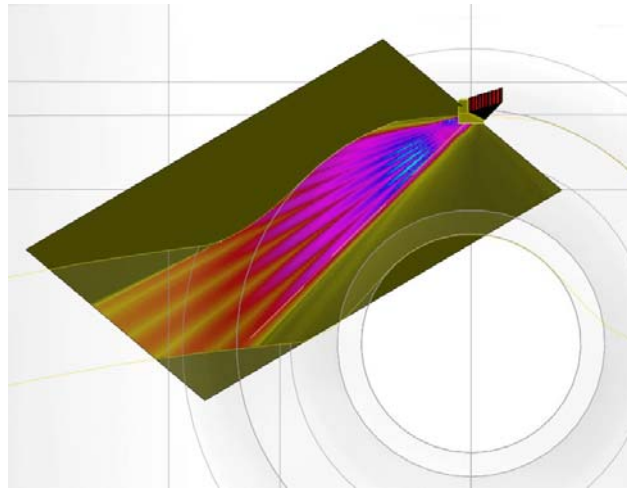

Fig.14. Axial view of the nozzle with overlaid ultrasonic field obtained at 35°-75° steering angles of the phased array in the case of the position on the slope between nozzle and pipe

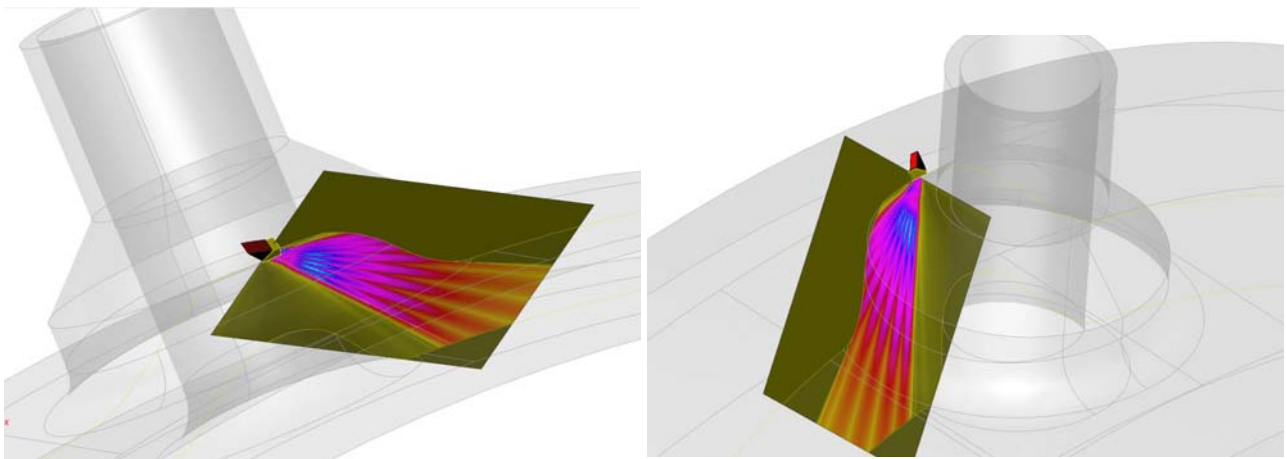

Fig.15. Different projections of the nozzle with overlaid ultrasonic field obtained at different steering angles of the phased array

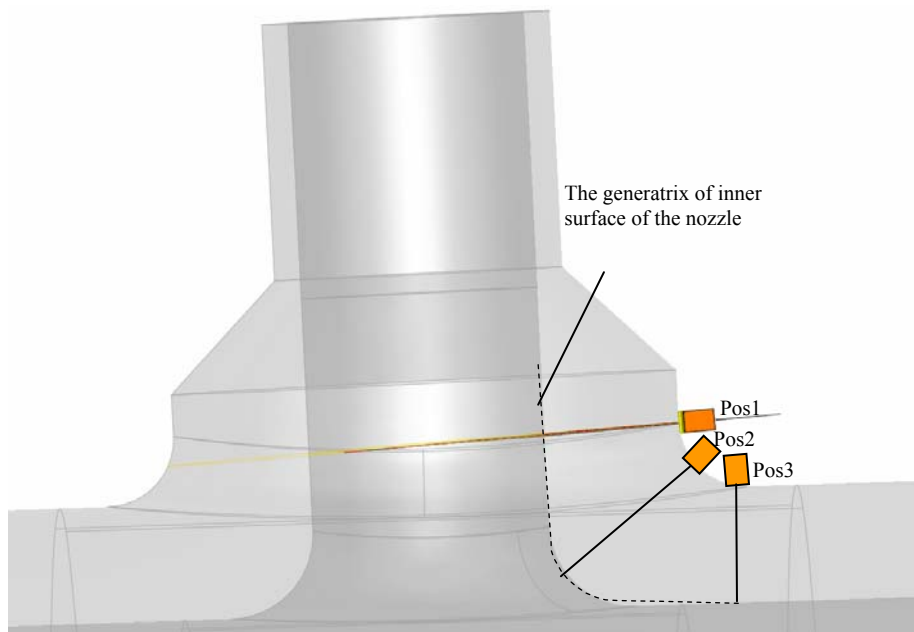

Fig.16. Side view of the nozzle with the possible positions of ultrasonic probes on outer surface

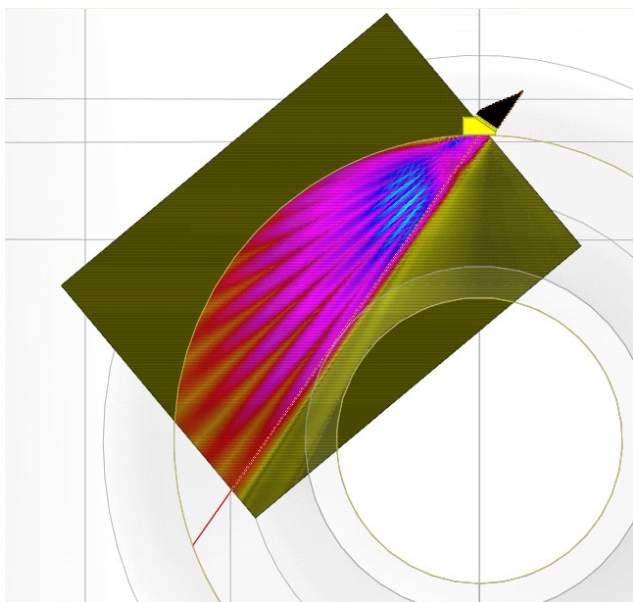

Fig.17. Axial view of the nozzle with overlaid ultrasonic field obtained at 35°-75° steering angles of the phased array in the case of the position 1 on the outer diameter of the nozzle

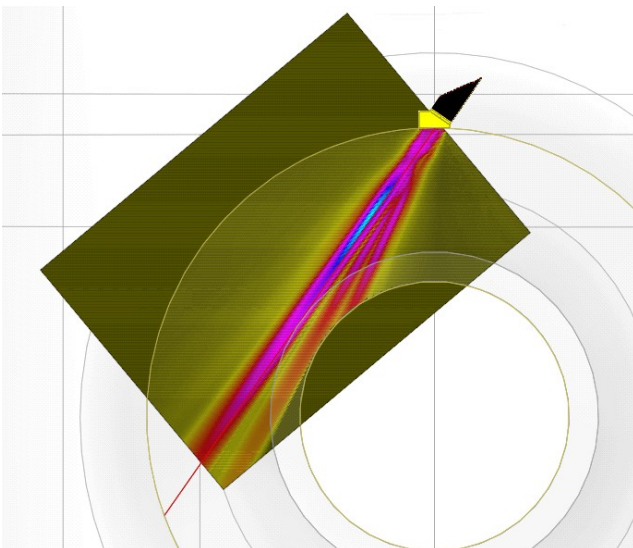

Fig.18. Axial view of the nozzle with overlaid ultrasonic field obtained at 25°-35° steering angles of the phased array in the case of the position 1 on the outer diameter of the nozzle

References

1. **Tanarro A., Garcia A.** Ultrasonic inspection of complex nozzles – application of new technologies. NDTnet. 1998. March. Vol.3. No.3. P.1-4.
2. **Moles M., Labbe S.** Ultrasonic inspection of pressure vessel construction welds using phased arrays. NDTnet. 3rd Middle East Nondestructive Testing Conference & Exhibition, 27-30 Nov 2005 Bahrain, Manama. P.1-17.
3. **Nanekar P. P., Shah B. K.** Advanced ultrasonic for in-service inspection of nuclear plants. 2007. P.1-8.
<http://www.igcar.ernet.in/events/ind2007>.
4. **Kemppainen M., Virkkunen I., Pitkanen J., Hukkanen K., Hanninen H.** Production of realistic artificial flaw in inconel 600 safe-end. Proceedings of the Conference on Vessel Penetration Inspection, Crack Growth and Repair, sponsored by USNRC and Argonne National Laboratory, 29 September - 2 October 2003. Washington D.C., Gaithersburg, USA. NUREG/CP-0191. Vol.1. P.51-60.
5. **Garcia A., Perez C., Fernandez F., Perez P.** Nozzle inspection using phased-array technology. NDTnet. 2004. 16th World Conference on NDT. P.1-4.
6. **Lareau J. P., Plis R. M.** Phased array imaging first use qualification effort: BWR feedwater nozzle inner radius inspection from vessel OD for a US nuclear power plant. NDTnet. 2002. May. Vol.7. No.05. P.1-7.
7. **Wustenberg H., Erhard A., Schenk G.** Scanning modes at the application of ultrasonic phased array inspection systems. NDTnet. 15th World Conference on Nondestructive Testing, Roma (Italy) 15-21 October 2000. P.1-13.
8. **Toullelan G., Nadim A., Casula O., Dumas P., Abittan E., Doudet L.** Inspection of complex geometries using flexible phased-array transducers. NDTnet. 17th World Conference on Nondestructive Testing, 25-28 Oct. 2008. Shanghai. China. P.1-7.
9. **Calmon P., Premel D.** Integrated NDT models in CIVA. Commissariat a l’Energie Atomique. 2005. P.1-13.
<http://www-civa.cea.fr/home/liblocal/docs/publioff>.
10. **Calmon P., Mahaut S., Chatillon S., Raillon R.** CIVA: an expertise platform for simulation and processing NDT data. Ultrasonics. 2006. Vol.44. P.975-979.

E. Jasiūnienė, L. Mažeika, O. Tumšys

Vamzdžių sujungimo vidinio paviršiaus tyrimo, naudojant ultragarsines fazuotas gardeles, galimybės

Reziumė

Šio darbo tikslas yra nustatyti ultragarsinės gardelės pozicijas ir skenavimo kampus, tinkamus vamzdžių sujungimo vidiniams skersmeniui matuoti. Ultragarso bangos sklidimas buvo modeliuojamas naudojant programinės įrangos paketą CIVA.

Pateikti rezultatai rodo galimas ultragarsinės gardelės pozicionavimo vietas ir minėtam skersmeniui tikrinti tinkamus skenavimo kampus.

Pateikta spaudai 2010 09 15

DOI: 10.5755/j01.u.65.3.17156