

Testing of the middle zone of the rail weld

E. Jasiūnienė

Ultrasound Institute, Kaunas University of Technology,
Studentu 50, LT-51368 Kaunas, Lithuania

Abstract

There are several millions aluminothermic welds on the European rail network. The welds are a critical safety component of the rail infrastructure. The consequences of a single failure could result in the derailment.

The objective of this investigation was to test using CIVA software the proposed configuration of the ultrasonic phased array for testing of the middle zone of the weld, where shrinkage of the body is usually present. The propagation of the ultrasonic wave in the rail with shrinkage type defects has been modelled using CIVA software.

The presented results demonstrate that it should be possible to locate shrinkage type defects in the rail weld using 2MHz ultrasonic phased array.

Keywords: rail, weld, shrinkage, ultrasonic NDT, phased array, CIVA

Introduction

There are several millions aluminothermic welds in the European rail network. The welds are a critical safety component of the rail infrastructure. Not detected defect could result in the derailment of the train [1].

For welded objects with thickness under about 20 mm, 60° and 70° probes are used, and for thickness over 20 mm, 45° and 60° probe angles are recommended [2]. The refraction angles generally used for testing of rail welds are 45° and 70° degrees [3].

The majority of ultrasonic inspection of rail welds is performed using handheld conventional angle beam transducers, which are manually scanned. In order to test the whole volume of a weld without mechanical scanning, ultrasonic arrays could be used. One of advantages of using phased arrays is possibility to use sectorial electronic scanning [4-6].

The main purpose of this task was to test using CIVA software the proposed configuration of the ultrasonic phased array for testing of the middle zone of the weld, where shrinkage of the body is usually present. In European and British standards [7] for railway applications for a test of the middle zone of the foot of the weld, 2 MHz or 4 MHz transducers with 45° angle (shear waves) are recommended (Fig. 1).

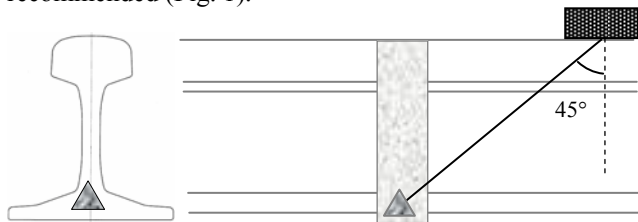

Fig. 1. Positioning of the probe for testing middle zone of the rail weld according to European standards [7]

Modelling of ultrasonic field

First of all computations of ultrasonic field coverage of the sample were performed. For modelling 32 elements 2MHz linear phased array on the wedge for generation of the shear waves was used. The wedge parameters, used for modelling are given in Fig.2. The array was excited using

2 MHz signal shown in Fig.3, the sampling frequency was 40MHz, the bandwidth 65%. The array parameters were the following (Fig.4): the element width – 0.67mm, the gap between elements 0.08mm, the pitch – 0.75mm, the active aperture – 23.92mm, the passive aperture – 10mm.

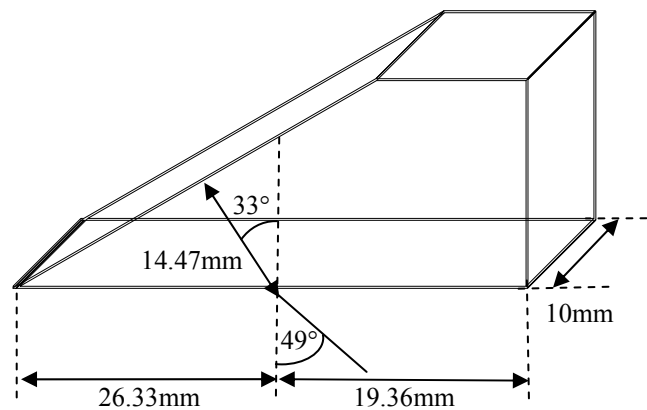

Fig. 2. Wedge parameters

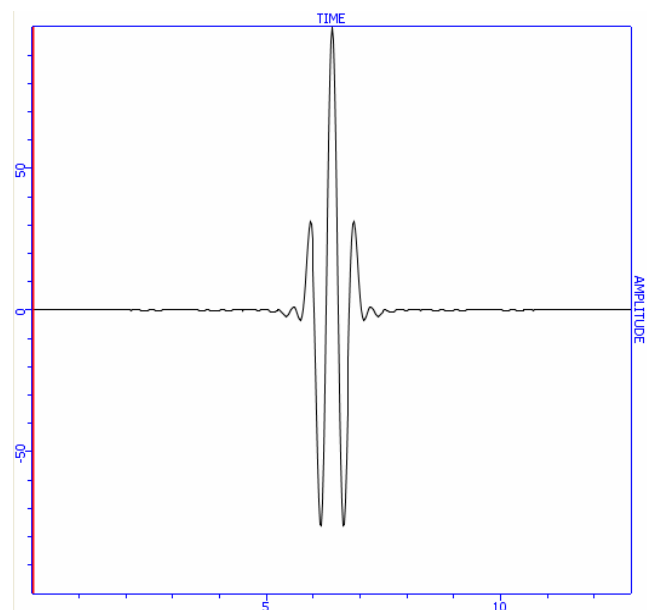

Fig. 3. Excitation signal

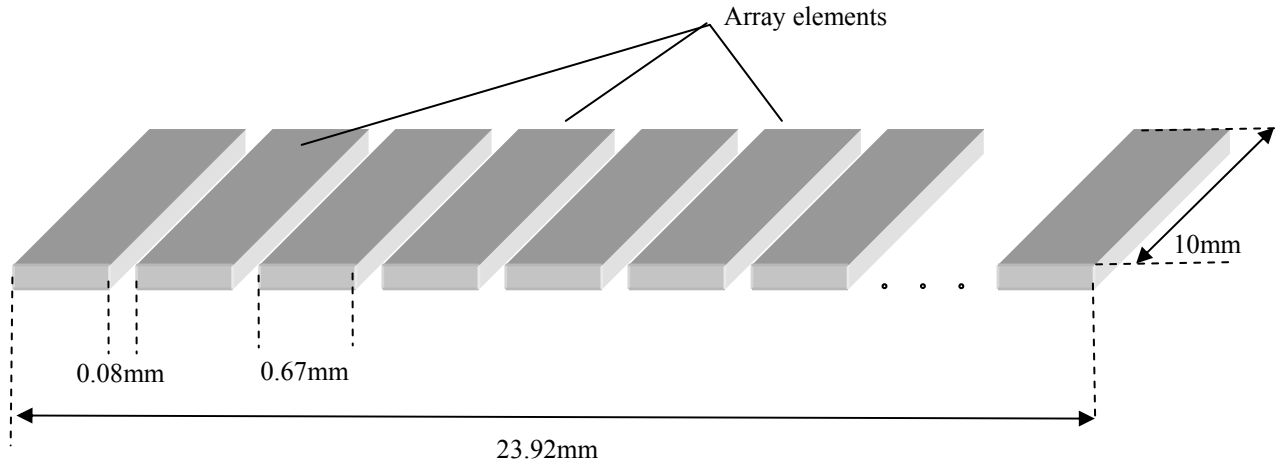

Fig. 4. Geometry and arrangement of 1-D linear array

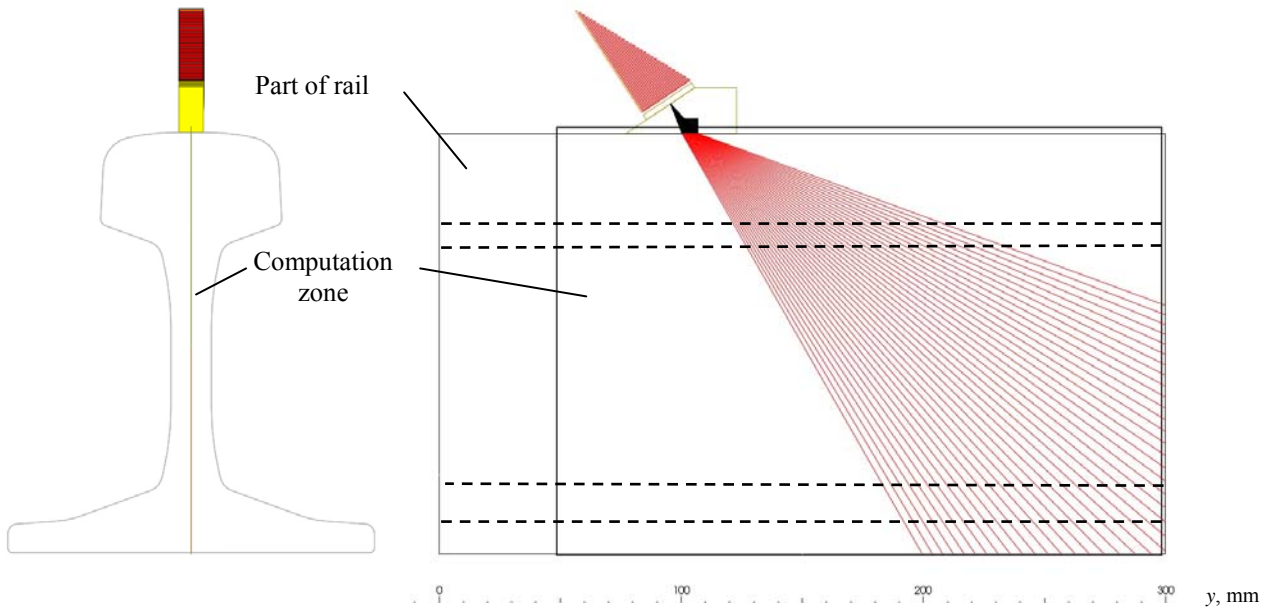

Fig. 5. Positioning of the probe on the sample and ultrasonic field computation zone

Positioning of the probe on the sample and ultrasonic field computation zone are shown in Fig.5. In modelling a rail sample with 300mm length was used. It was assumed, that the rail is made from steel and the shear waves are excited, which propagate with 3255m/s velocity. The phased array was used in a sectorial scanning mode; the

beam was scanned from 30° to 70° degrees with a step of one degree. The ultrasonic fields at 30°, 45° and 70° degrees superimposed on the rail sample are presented in Fig.6-8.

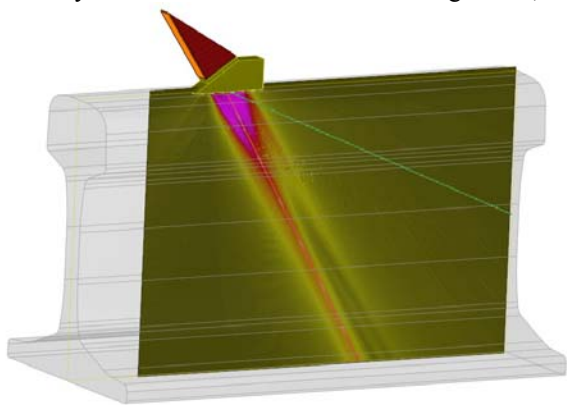

Fig.6. Ultrasonic field of 2MHz phased array at 30° degrees superimposed on the rail sample

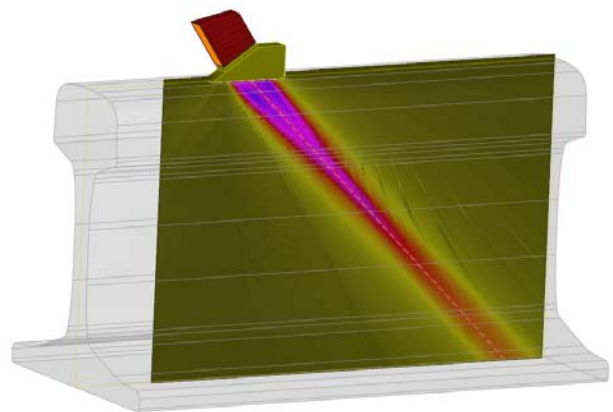
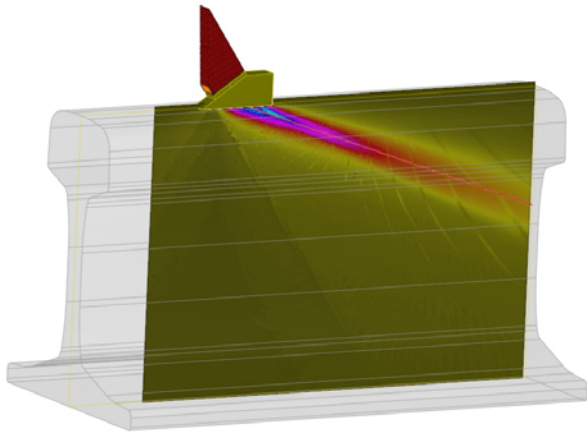

Fig.7. Ultrasonic field of 2MHz phased array at 45° degrees superimposed on the rail sample



In order to see the coverage of the rail with ultrasonic beam in another plane, simulation of the ultrasonic field in the perpendicular plane was performed. Positioning of the probe on the sample and the ultrasonic field computation zone in two projections and in 3D is shown in Fig.9. The computation zone is oriented with 45° angle.

The calculated ultrasonic field is presented in 3D view in Fig.10. From the presented results it is possible to see that the ultrasonic field covers the whole middle zone of the rail – that is, the defects located in the middle zone of the rail should be detected.

Fig.8. Ultrasonic field of 2MHz phased array at 70° degrees superimposed on the rail sample

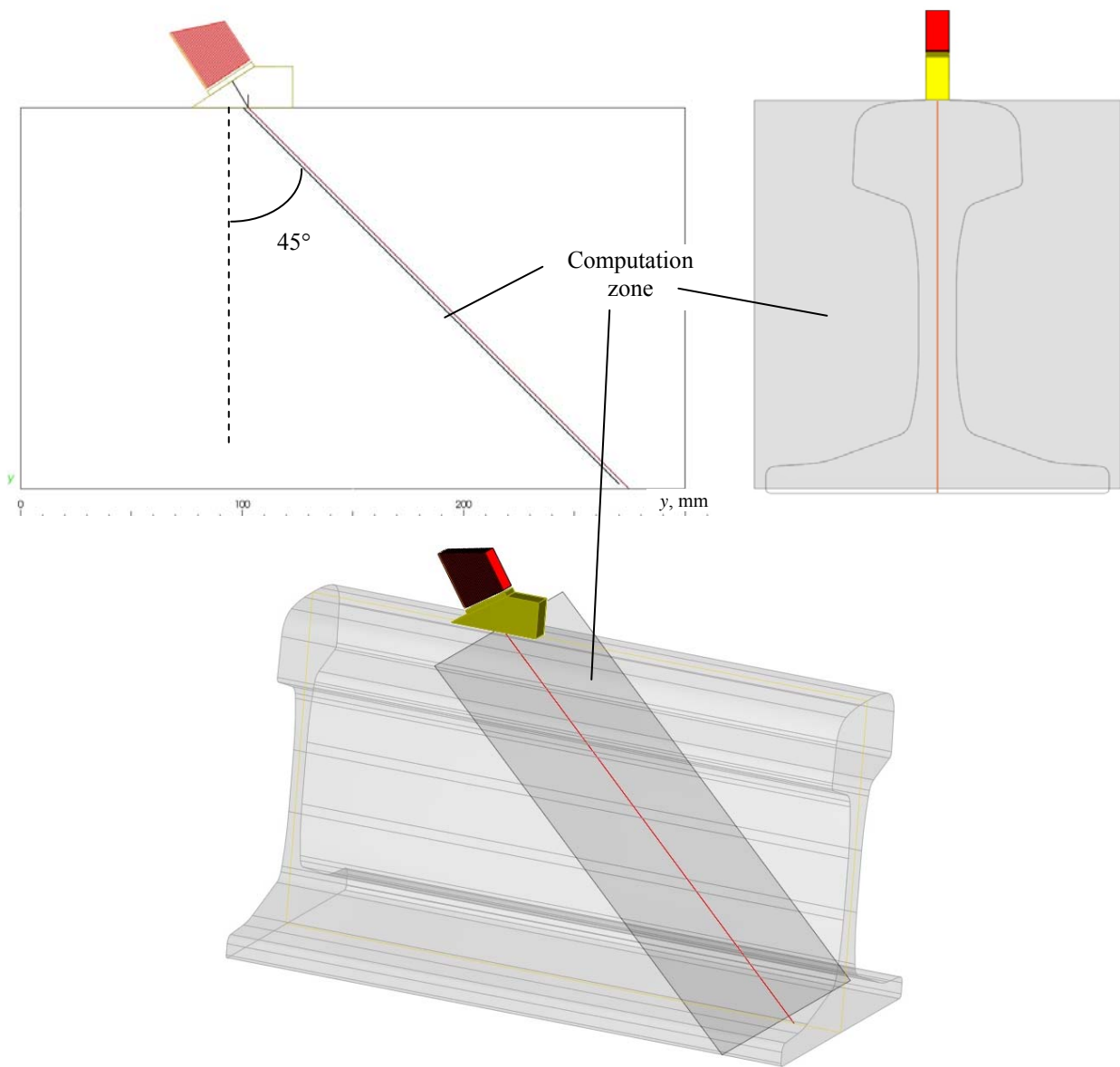

Fig.9. Positioning of the probe on the sample and ultrasonic field computation zone

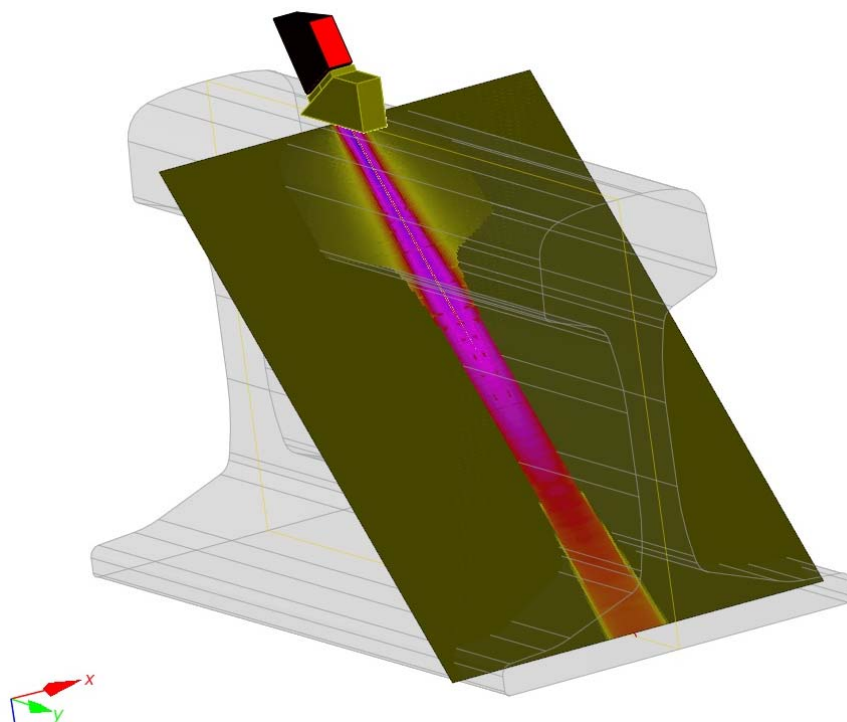

Fig.10. Ultrasonic field of 2MHz phased array at 45° degrees superimposed on the rail sample.

Modelling of the shrinkage defect response

Modelling of the ultrasonic testing of the middle zone of the weld, where shrinkage of the body is usually present was performed. From the available photos of the shrinkage defect in the rail (Fig. 11) it was assumed, that the shrinkage defect is of the triangle shape. So, in the middle of the weld, the defect in a triangle shape, 20 mm in width was modelled (Fig. 12).



Fig.11. Photo of the rail with the shrinkage defect

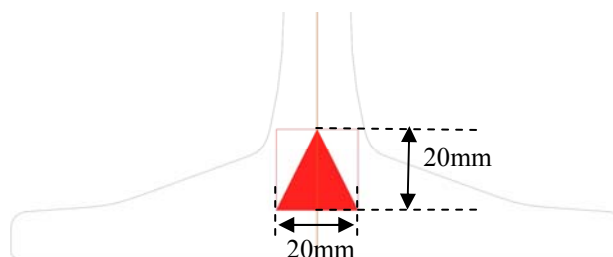

Fig.12. The modelled shrinkage defect

The defect's top was positioned 140mm from the top surface of the rail (Fig.13). The phased array centre was positioned at 100mm distance from the 35mm weld (Fig.13). The sectorial scan from 30° to 70° degrees with a step of 1° degree was performed.

The zoomed defect response superimposed on the railed sample is presented in Fig.14. It can be observed that the reflection from the upper part of the defect is very weak. The difference between reflections from the upper and lower parts of the defect is 30 dB.

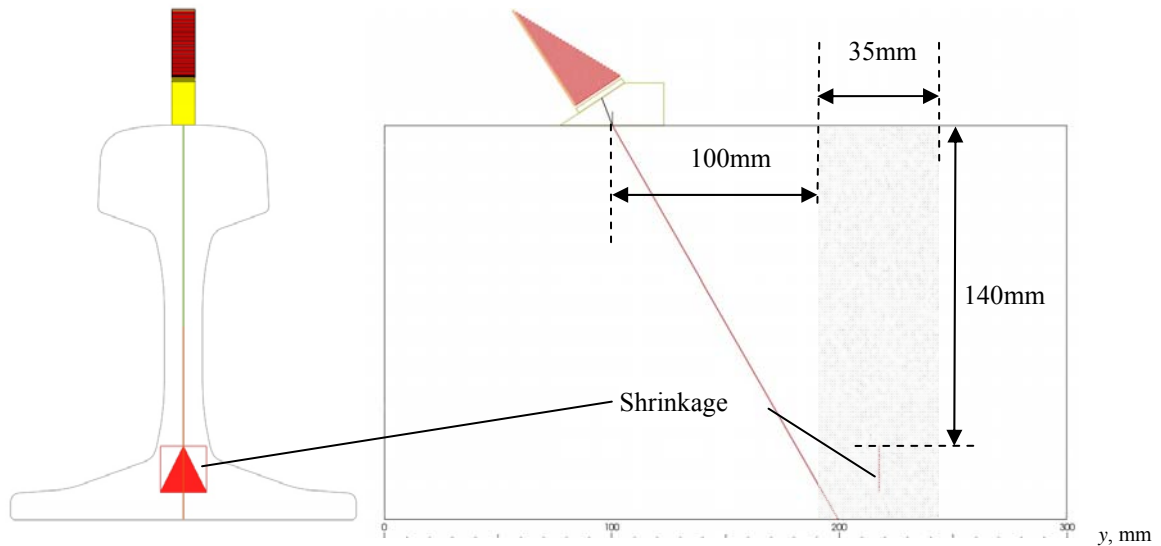

Fig.13. The position of the shrinkage defect in weld

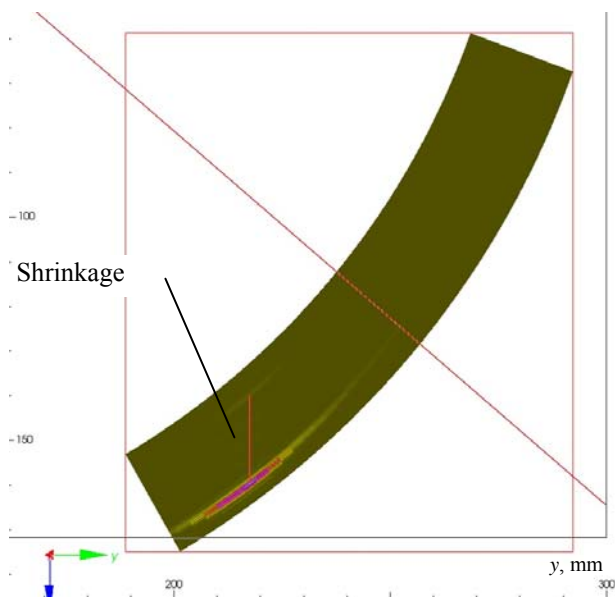

Fig.14. Defect response superimposed on the rail sample

After examining the photo of the shrinkage defect more closely, another 2D CAD model of the defect was created (Fig.15).

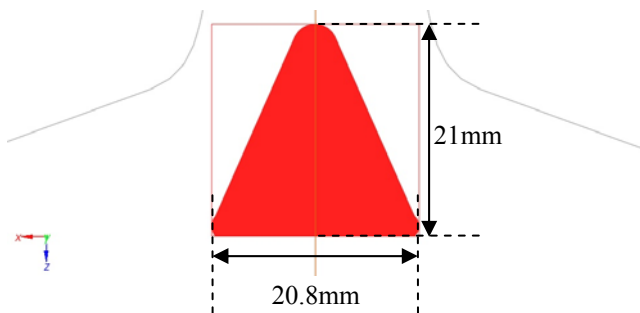

Fig.15. The second 2D CAD model of the shrinkage defect

The defect was positioned exactly the same as in the previous case. Again, the sectorial scan from 30° to 70°

degrees with a step of 1° degree was performed. The B-scan image of the defect response is presented in Fig.16. In this case the reflection from the upper part of the defect is stronger. The difference between reflections from the upper and lower parts of the defect is 14 dB. The defect response superimposed on the rail sample in 3D is presented in Fig. 17.

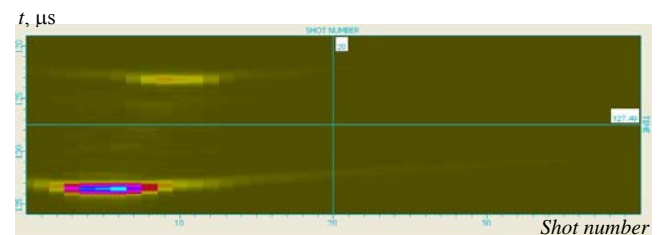

Fig.16. B-scan of the shrinkage defect

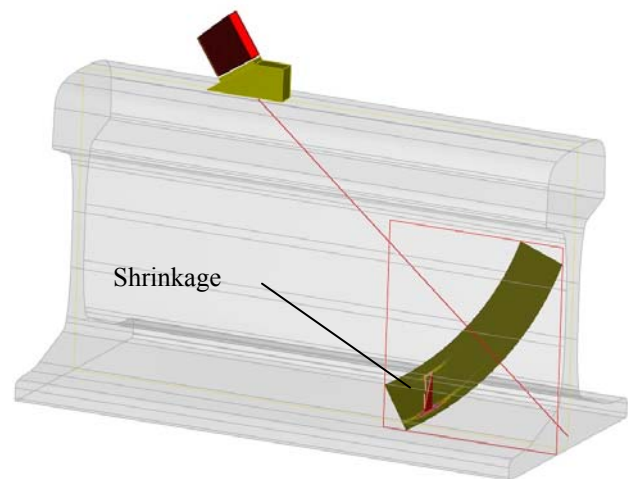

Fig.17. Defect response superimposed on the rail sample in 3D

Next the influence of the size of the defect was investigated. The size of the shrinkage was decreased twice – the size of the triangle side was 10mm. The top of the defect was kept at the same position as before – 140mm (Fig. 18).

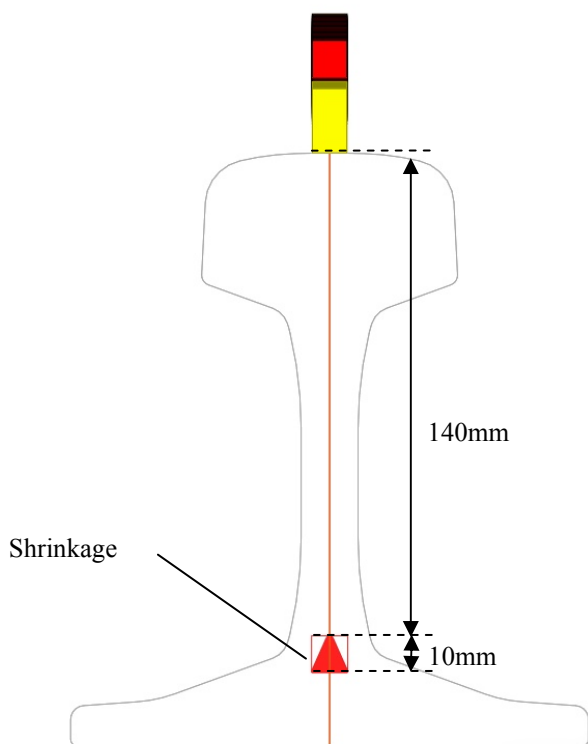

Fig. 18. The position of the shrinkage defect in a weld

Again, the sectorial scan from 30° to 70° degrees with a step of 1° degree was performed. The B-scan image of the defect response is presented in Fig. 19. Even in the case of the smaller defect the reflection from the upper part of the defect is still visible. The difference between reflections from the upper and lower parts of the defect is 17 dB. The defect response superimposed on the rail sample in 3D is presented in Fig. 20.

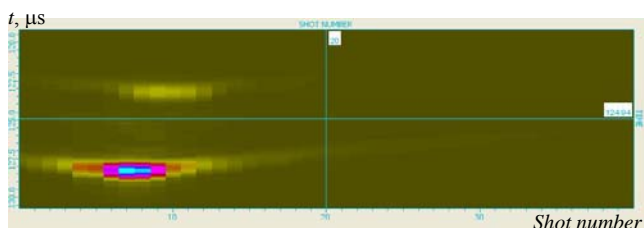

Fig. 19. B-scan of the shrinkage defect

Conclusions

The presented results demonstrate that it should be possible to locate shrinkage type defects using 2MHz ultrasonic array positioned on top of the rail head beside the weld, when the beam is scanned from 30° to 70° degrees.

Acknowledgements

The part of this work was sponsored by the European Union under the Framework-7 project "Development of an ultrasonic technique, sensors and systems for the volumetric examination of alumino-thermic rail welds" RAILECT. The Project is coordinated and managed by TWI (UK).

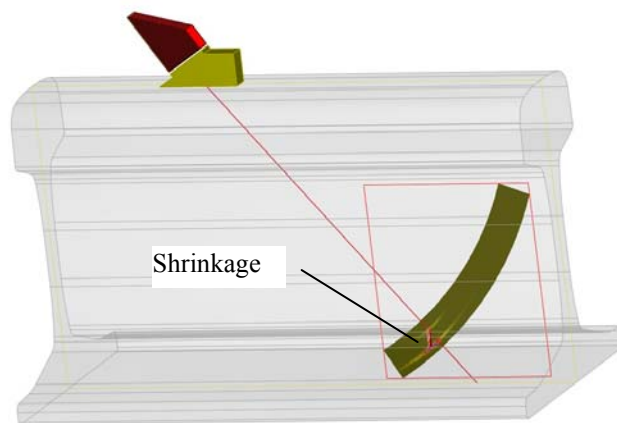

Fig. 20. Defect response superimposed on the rail sample in 3D

References

1. **Papaelias M. Ph., Roberts C., Davis C. L.** A review on non-destructive evaluation of rails: state-of the art and future development. Proc. IMechE. Vol. 222. Part F J. Rail and Rapid Transit 2008. P.367-384.
2. **Ginzel E. A.** Weld inspection of ultrasonic Inspection 2. Training for non-destructive testing ultrasonic Inspection 2. Training for non-destructive testing. 1995. ISBN 1-895518-14-8.
3. **Clark R.** Rail flaw detection: overview and needs for future developments. NDT&E International. 2004. Vol. 37. P.111-118.
4. Application of ultrasonic phased arrays for rail flaw inspection. U.S. Department of Transportation. Federal Railroad Administration. Washington, DC 20590. This document is available to the U.S. public through the National Technical Information Service Springfield, VA 22161. July 2006. DOT/FRA/ORD-06/17.
5. **Bredif P., Plu J., Pouligny P. and Poldevin C.** Phased-array method for the ut-inspection of French rail repairs. CP975. Review of Quantitative Nondestructive Evaluation. Ed by D. O.Thompson and E.Chimenti. 2008. Vol.27. American Institute of Physics 978-0-7354-0494-6/08.
6. Advances in phased array ultrasonic technology applications-Advanced practical NDT series. Chapter 1. P.5-25
http://www.olympos-ims.com/data/File/advances_book/Applications_Ch1.en.pdf
7. Railway applications-Track Aluminothermic welding of rails. British standard BS EN 14730-1:2006.

E. Jasiūnienė

Geležinkelio bėgio suvirinimo siūlės vidurinės dalies tikrinimas

Reziumė

Europos geležinkelių tinkle yra keletas milijonų aluminoterminių suvirinimo siūlių. Suvirinimo siūlės - kritinis geležinkelių infrastruktūros dėmuo, nes jose gali atsirasti įvairių defektų. Šio darbo tikslas buvo nustatyti defekto aptikimo suvirinimo siūlės vidurinėje dalyje galimybes naudojant 2 MHz keitiklių gardele. Ultragarso bangos sklaidimas buvo modeliuojamas naudojant programinės įrangos paketą CIVA. Pateikti rezultatai rodo, kad defektai suvirinimo siūlės vidurinėje dalyje gali būti aptikti naudojant ultragarsinę keitiklių gardele, kuri pozicionuojama šalia suvirinimo siūlės bėgio viršuje.

Pateikta spaudai 2010 09 27

DOI: 10.5755/j01.u.65.3.17157