

## Development of the non-damped wide-band ultrasonic transducers

A. Vladiškauskas, E. Žukauskas, R. Šlitteris, R. Raišutis, G. Seniūnas

*Prof. K. Baršauskas Ultrasound Institute,  
Kaunas University of Technology,  
Studentu 50, LT-51368 Kaunas, Lithuania*

### Abstract

In this article low frequency non-damped wide-band ultrasonic transducers are described. The important part of the non-damped transducers is the size of the piezoelement which can operate as a broadband transducer. The two kinds of piezoelements are investigated. The first, the non-damped piezoelement with dimensions of  $5 \times 5 \times 5$  mm was used as an experimental model. Ultrasonic signals and their frequency responses are presented for a single piezoelement and for the piezoelement with matching layer. The two cases of the transmitter and the receiver, in which the piezoelement alone and with the matching layer was used, are investigated. It is shown, that the piezoelement acting as a receiver gives the shorter pulse and the wider frequency response, than piezoelement acting as a transmitter. Also, it is shown that the single non-damped transducer gives a higher amplitude (by 10 ... 12 dB) than hard damped transducers.

**Keywords:** non-damped transducer, wide-band transducer, finite element modelling, matching layer

### Introduction

At present day low frequency ultrasonic techniques are widely used in many fields for investigation of composite materials during manufacture and checking these materials during service time. In some cases, composite materials under a test have multi-layered structures which consist of a few layers possessing different acoustic and mechanical properties. These multi-layer structures consist of different polymer materials or polymer materials and other materials sheets, also metal sheets. The layers of different materials are joined by glue, which creates acoustical mismatching and additional losses of the ultrasonic waves. The object under investigation can have large dimensions, therefore there is demand to develop ultrasonic methods allowing to carry out the investigation of very long distance with a necessary accuracy. It can be made using low frequency, high resolution and sensitivity ultrasonic transducers.

Many ultrasonic methods and transducers are used for investigations of multi-layered composite materials. The air-coupled methods [1-3] are very attractive and successfully used for investigation of the multi-layered composite materials. However, the air-coupled ultrasonic methods have a basic shortcoming. The total losses of this method can achieve up to -180 dB. The increasing of the distance between the transmitter and the receiver gives the decrease of the reliability of the ultrasonic measurement due to loss of the informative signal which takes place due to material properties of multi-layered structures. However, there is a method which allows to investigate the samples possessing large dimensions, when the two transducers at the fixed distance between them carry out the scanning of the sample surface. The transducers are mounted into a pitch-catch configuration for generation and reception of ultrasonic guided waves [4-6]. In order to decrease the losses of air-coupled transducer, the active aperture of the transducer should be increased, but the achievable spatial resolution becomes lower.

The immersion methods give lower losses due to better matching of the acoustic impedances of the transducers,

water and the testing object [7-9]. A few ultrasonic through-transmission techniques were used for immersion and air-coupled investigation [7]. The immersion technique has a better resolution due to the higher frequency, but the air-coupled technique is preferable to be used, because it does not require any coupling liquid.

The immersion – contact method was used in [8], where the contact transmitting transducer was permanently fixed by epoxy glue on the surface of the aluminium plate. The receiving transducer was placed at the distance of 10 mm over the opposite surface of the plate and scanned along two perpendicular directions.

Using the immersion experimental set-up and the contact type excitation for generation of the longitudinal displacements, the propagation of  $S_0$  mode in a plate loaded by water was investigated [9].

Inspection of the carbon fibre reinforced plastics (CFRP) rod using immersion-contact techniques was used in [10]. The transmitting thickness mode ultrasonic transducer with the diameter of 4 mm and frequency of 400 kHz has been mounted on the polished edge of the circular-shape rod by a quick-setting epoxy glue and the receiving ultrasonic transducer with the diameter of 4 mm has been scanned over the surface of the sample in order to register the leaky waves.

The ultrasonic investigations of the composite materials at low frequencies using contact methods give good results due to matching of the acoustic impedance of the investigated sample and the radiation surface of transducers. Therefore the contact methods are useful for the scanning systems when the small contact type transducers are used, but the low frequency and small area contact give the broadband beam pattern of the transducers [11]. It gives significant decrease of the ultrasonic signal amplitude when the distance between the transmitter and the receive increases. Then in the long range ultrasonic technology and structural health monitoring of the composite structures the transducers with a high sensitivity are necessary to be used. The aim of this work is to develop more efficient ultrasonic contact type transducers.

## Finite element modelling

The finite element method is a technique for predicting the responses of structures and materials to environmental factors such as force, heat, vibration and etc. It is also widely used in a numerical simulation of physical and mechanical behaviours of various structures.

The finite element modelling of the piezoelectric transducer was performed using ANSYS finite elements code. The coupled finite element matrix for piezoelectric structure is [12]:

$$\begin{bmatrix} [\mathbf{M}] & [0] \\ [0] & [0] \end{bmatrix} \begin{Bmatrix} \{\ddot{\mathbf{u}}\} \\ \{\ddot{\mathbf{V}}\} \end{Bmatrix} + \begin{bmatrix} [\mathbf{C}] & [0] \\ [0] & [0] \end{bmatrix} \begin{Bmatrix} \{\dot{\mathbf{u}}\} \\ \{\dot{\mathbf{V}}\} \end{Bmatrix} + \begin{bmatrix} [\mathbf{K}] & [\mathbf{K}^z] \\ [\mathbf{K}^z]^T & [\mathbf{K}^d] \end{bmatrix} \begin{Bmatrix} \{\mathbf{u}\} \\ \{\mathbf{V}\} \end{Bmatrix} = \begin{Bmatrix} \{\mathbf{F}\} \\ \{\mathbf{L}\} \end{Bmatrix}, \quad (1)$$

where  $[\mathbf{M}]$  is the structural mass matrix,  $[\mathbf{C}]$  is element the structural damping matrix,  $[\mathbf{K}]$  is the structural stiffness matrix,  $[\mathbf{K}^d]$  is the dielectric permittivity coefficient matrix,  $[\mathbf{K}^z]$  is the piezoelectric coupling matrix,  $\{\mathbf{F}\}$  is the structural load vector,  $\{\mathbf{L}\}$  is the vector of nodal, surface and body charges,  $\{\mathbf{u}\}$  is the displacement vector,  $\{\mathbf{V}\}$  is the vector of nodal electrical potential.

The volume of the piezoceramic cube was meshed using SOLID5 element. The SOLID5 element has a 3D magnetic, thermal, electric, piezoelectric and structural field capability with limited coupling between the fields. The element has eight nodes with up to six degrees of freedom at each node. The volume of the front layer was meshed using SOLID45 element which is used for modelling of the 3D solid structures. The element is defined by eight nodes having three degrees of freedom at each node: translations in the nodal  $x$ ,  $y$ , and  $z$  directions.

During modelling it was assumed that the active element of the piezoelectric transducer was made of Pz29 piezoceramic. The properties of the Pz29 piezoceramics are presented by Ferroperm and the stiffness matrix, the piezoelectric matrix and the dielectric permittivity matrix  $[\boldsymbol{\varepsilon}]$  are the following:

$$\mathbf{C} = \begin{bmatrix} 134 & 89.7 & 85.7 & 0 & 0 & 0 \\ 89.7 & 134 & 85.7 & 0 & 0 & 0 \\ 85.7 & 85.7 & 109 & 0 & 0 & 0 \\ 0 & 0 & 0 & 18.5 & 0 & 0 \\ 0 & 0 & 0 & 0 & 18.5 & 0 \\ 0 & 0 & 0 & 0 & 0 & 22 \end{bmatrix} \text{ GPa,}$$

$$\mathbf{e} = \begin{bmatrix} 0 & 0 & 0 & 0 & 13.4 & 0 \\ 0 & 0 & 0 & 13.4 & 0 & 0 \\ -5.06 & -5.06 & 21.2 & 0 & 0 & 0 \end{bmatrix} \text{ C/m}^2,$$

$$\boldsymbol{\varepsilon}_r^S = \begin{bmatrix} 1341 & 0 & 0 \\ 0 & 1341 & 0 \\ 0 & 0 & 1221 \end{bmatrix}.$$

The density of the piezoceramics is  $7460 \text{ kg/m}^3$ .

The front layer of the piezoelectric transducer was made of fibre glass. It is assumed that the used material is

quasi - isotropic and the Young's modulus is  $5.26 \text{ GPa}$ , the Poisson's ratio is  $0.36$  and the density is  $1200 \text{ kg/m}^3$ .

The ultrasonic transducer was excited by a half period of the  $200 \text{ kHz}$  electrical signal, e.g., duration of the pulse is  $2.5 \mu\text{s}$ . The amplitude of the pulse was  $20 \text{ V}$ .

The graphical representation of the finite element model and dimensions are presented in Fig. 1.

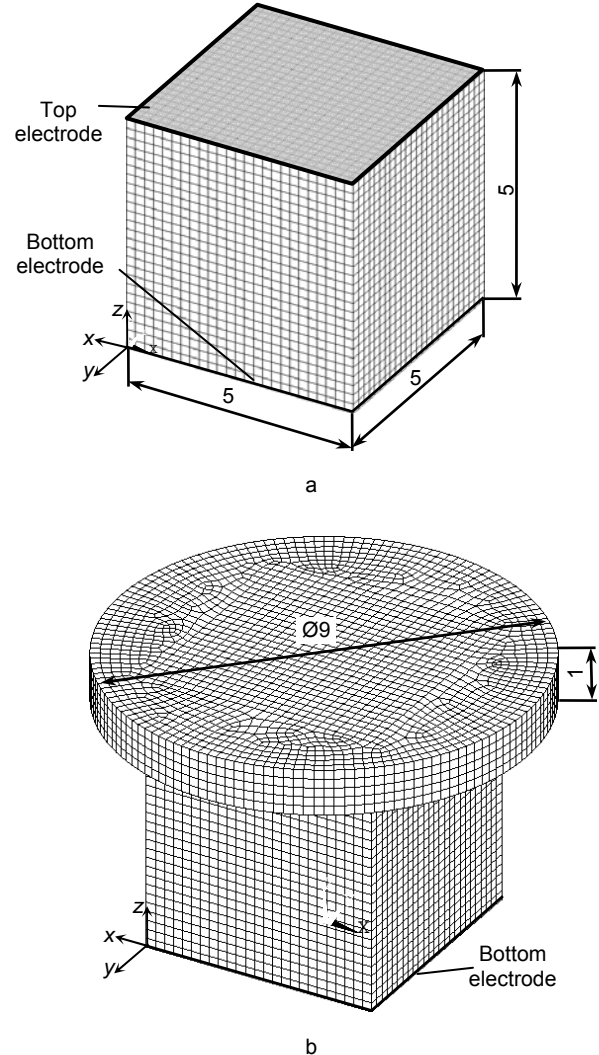

Fig. 1. Graphical representation of the finite element model of piezoelectric transducer: a - piezoceramic cube, b - piezoceramic cube with front matching layer

Displacements of the single piezoceramic cube and the piezoceramic cube with a front matching layer oscillating in vacuum at the time instants  $5 \mu\text{s}$  and  $7 \mu\text{s}$  after the excitation moment are presented in Fig. 2. The results show the thickness mode oscillations of the piezoelectric cube. Such configuration of the piezoelectric element may be used effectively for generation of ultrasonic waves. The strong oscillations of the unconstrained edges of the front matching layers can be seen.

Time diagrams of the oscillations of the radiating surface of the ultrasonic transducer ( $xy$  plane) along  $z$  directions were obtained by averaging the particle velocity components ( $z$  direction) on the transducer surface. The normalized time diagrams are shown in Fig. 3. Duration of

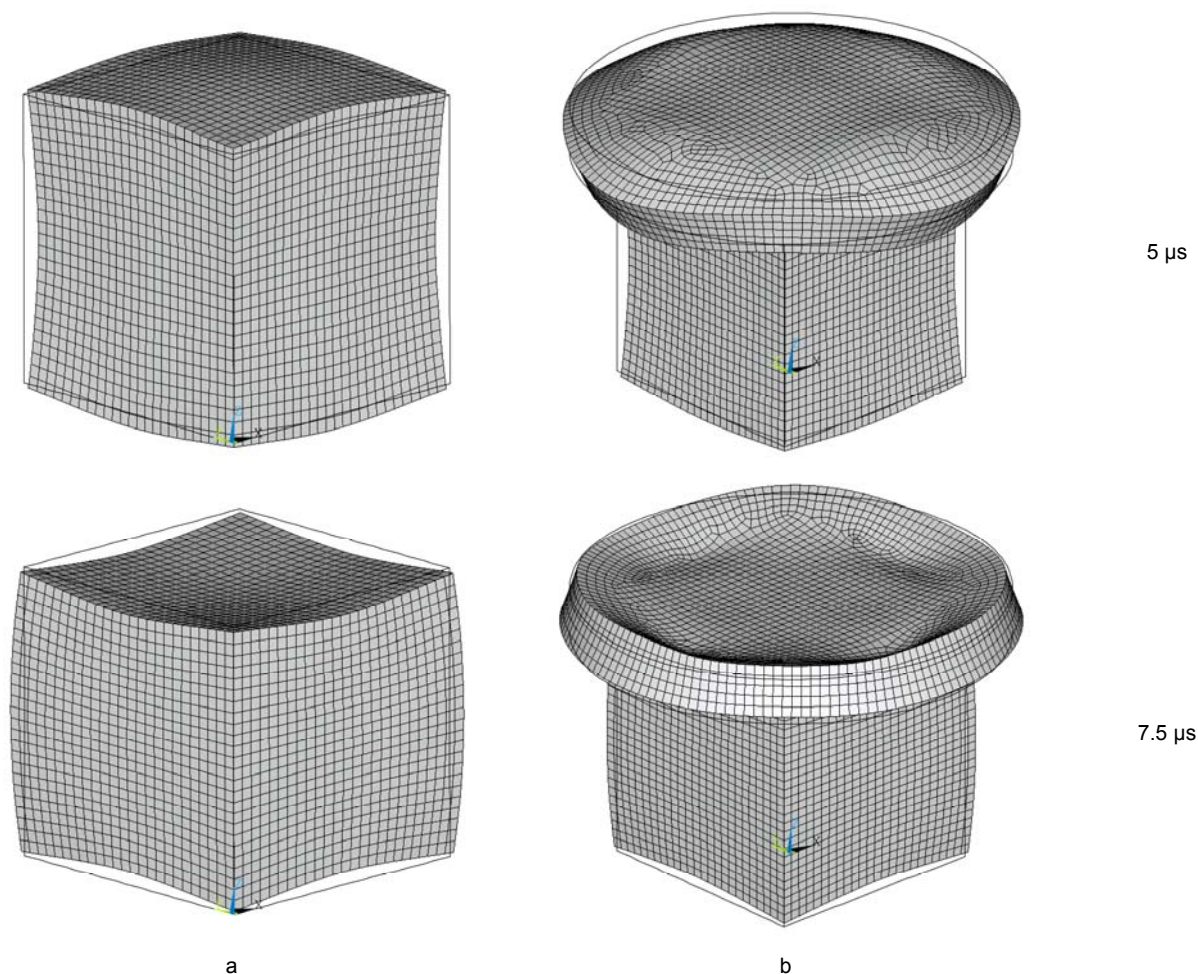

Fig. 2. Displacements of the piezoceramic cube (a) and piezoceramic cube with fibreglass front matching layer (b) oscillating in vacuum at the different instants of time

the signal obtained in the case of the single piezoceramic cube is 5 periods and duration of the signal obtained in the case of the piezoceramic cube with the front matching layer is 10 periods. This can be explained by oscillations of the unconstrained edges of the front layer.

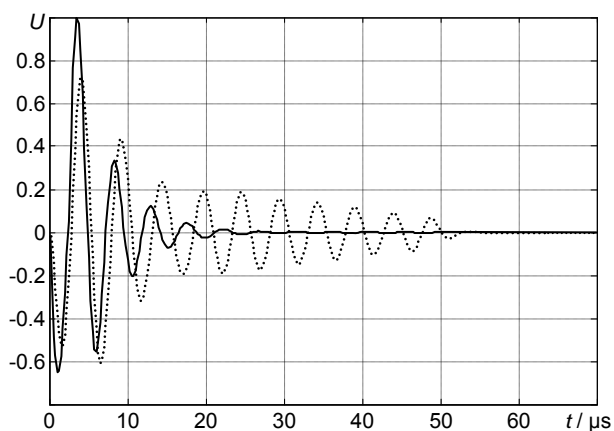

Fig. 3. Normalized time diagrams of the particle velocities at the surface of the ultrasonic transducer. The solid line - piezoceramic cube, the dotted line - piezoceramic cube with the front matching layer

### Construction of transducers

The low frequency contact type ultrasonic transducers can operate as a mechanical scanning device and as a permanently fixed transducer. This type of the transducers possess good transmission of ultrasonic waves to the sample due to matching of the acoustical impedances between the surfaces of the sample and the transducer. It allows to transmit and to receive many types of ultrasonic waves, therefore is used for investigation of composite materials such as the carbon fibre reinforced plastics (CFRP) and the glass fibre reinforced plastics (GFRP). The investigation of these materials using broadband low frequency contact type transducers was carried out in [13, 14], where the characteristics of the low frequency transducers in the time and frequency domains are presented. The transduction losses of the broadband transmitter and receiver face to face were -56 dB for the piezoelement having dimension of  $5 \times 5 \times 5$  mm. The hard damping of transducers gives the frequency band from 50 kHz up to 350 kHz (at -6 dB). Therefore these transducers are suitable for characterization of the composite materials according to the propagation and attenuation of ultrasonic waves. However, the transduction losses of transducer become essentially important in the

case of long range propagation of the ultrasonic waves along the structure of the test object.

There are a few possibilities for exciting low frequency ultrasonic waves using piezoceramic elements of different size and shape.

One of them is when the thickness and the diameter of the piezoelement of the broadband transducer are fixed [15, 16]. The relationship between the thickness and the diameter ( $d \approx 2a$ ) of the piezoelement enables to find the highest amplitudes in the centre of the piezoelement. The piezotransducer has the higher frequency modes. The piezotransducer has many vibration modes, but the lowest frequency is determined by the radial modes. The first modes of piezoelements are presented in Table 1. From Table 1 follows that this configuration of the piezoelement is too big for the contact type transducers.

Table 1.

Frequency, kHz	Thickness of the piezoelement, mm	Diameter of the piezoelement, mm
50	40.0	80
100	20.0	40
150	13.3	26.6
200	10.0	20.0
250	8.0	16.0
300	6.66	13.2
350	5.7	11.4

The useful way to develop the contact broadband low frequency transducers is to use the rectangle cube or the conical piezoelement [12-14]. The damping of the vibrating part gives the sufficient bandwidth.

However, the sensitivity of the broadband transducers is not high enough for the investigation of the composite materials over long distance.

The goal of this investigation was to develop, the low frequency small-size contact type transducers with the minimal transduction losses. For this purpose the low frequency transducers without damping were made. As background of the construction the broadband low frequency transducers were taken [11, 13, 14], where the dimensions of the used piezoelectric element were 5×5×5 mm. A few constructions were investigated (Fig. 4).

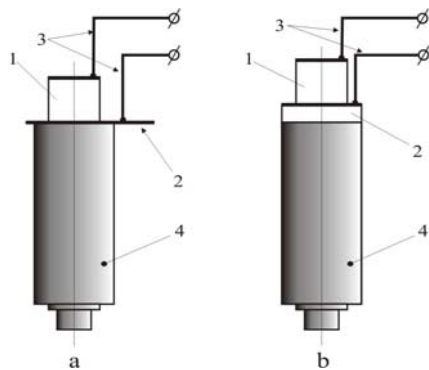

Fig. 4. The schemes of the investigation of the low frequency transducers: a – 1 – piezoelement, 2 – contact layer, 3 – connecting wires, 4 – broadband piezotransducer; b – 1 – piezoelement, 2 – matching layer, 3 – connecting wires, 4 – broadband piezotransducer.

The first task was to investigate the small piezoelement without any damping. The measurement scheme (Fig. 4a) consists of the piezoelement 1, the contact layer 2, the connecting wires 3 and the broadband transducer 4. The contact layer 2 consists of the thin metallic layer (thickness of 50 μm), which is needed to ensure the electrical contact between the piezoelement and the connecting wire.

In the measurement scheme (Fig. 4b) the matching layer 2 was used between the piezoelement 1 and the broadband transducer 4.

### Experimental investigation

Two measurement methods were used in the experimental investigation. At first, the broadband transducer was used as a receiver and the piezoelement was used as a transmitter. The excitation pulse with the amplitude of 20 V was used as a single period and three periods pulse and 200 V was used as a spike pulse. The single and three periods were used with the frequency of 200 kHz and the frequency of 2000 kHz was used for generation of the spike pulse. The received ultrasonic signal from the piezoelement is shown in Fig. 5.

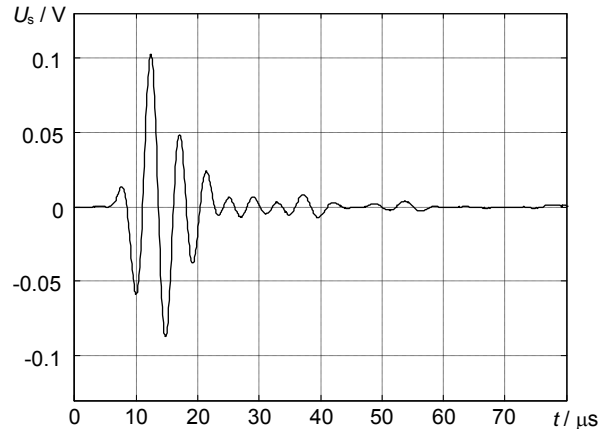

Fig. 5. The received ultrasonic signal in the case than the piezoelement was used as the transmitter.

The amplitude of the ultrasonic signal has increased about 12 dB, when the only one of the transducers – the transmitter was used without damping [13]. The estimated transduction losses of the non-damped transmitter and the broadband receiver were -44 dB. Separately, the transduction losses of the receiver were -28 dB and the transduction losses of the transmitter were -16 dB. The pulse response of the transmitter – receiver is shown in Fig. 5 and the frequency response of this signal is shown in Fig. 6. The short excitation pulse (0.5 μs) was used in order to get the pulse response of the transducer.

From the duration of the pulse follows that the non-damped transmitter gives the elongated pulse in the time domain comparing with the damped piezoelement. The frequency bandwidth is 140 kHz (Fig. 6). As it was presented previously, the frequency bandwidth of two broadband transducers gives the overall bandwidth of 300 kHz [14]. The decrease of the frequency bandwidth by two times gives the increase of the amplitude by four times.

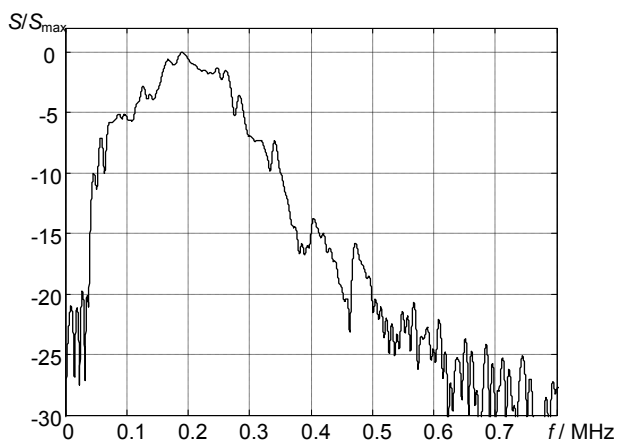

Fig. 6. The frequency response of the transmitter – receiver of the single cube

The matching layer helps to protect the piezoelement and to match the acoustical impedance of the investigated sample with the acoustical impedance of the piezoelement. Also in this construction of the transducer is used as a holder of the piezoelement body in the housing. The thickness of the matching layer was 1 mm. The ultrasonic signal of the broadband receiver and the proposed construction (Fig. 4b) is shown in Fig. 7. The matching layer by itself changes the shape and the amplitude of the received signal. In this case the ultrasonic signal becomes longer in the time domain due to vibrations of the matching layer edges. Such effect was described in the modelling part of this article.

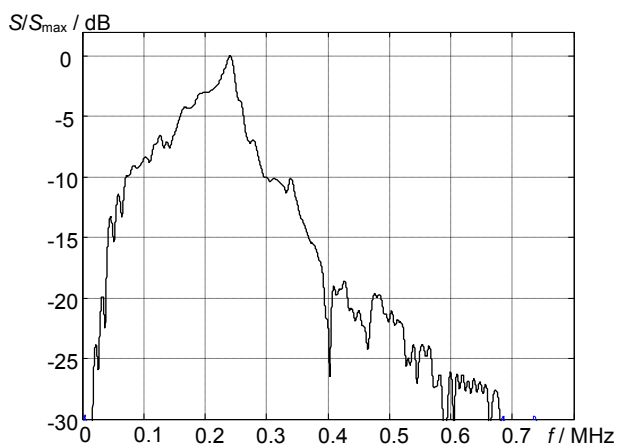

Fig. 7. The ultrasonic signal of the broadband transducer and the piezoelement with matching layer having thickness of 1 mm

Therefore, the larger edges of the matching layer elongate the vibration process of the non-damped piezoelement. The amplitude of the received signal through the matching layer decreased about 10 %. In the case when the thickness of the matching layer increases, the amplitude of the received signal decreases. Also the decreasing of amplitude of the signal depends on the acoustical impedance of the matching layer.

The frequency response is shown in Fig. 8, where the frequency bandwidth is 110 kHz. The matching layer (thickness of 1 mm) decreases the frequency bandwidth about 40 kHz.

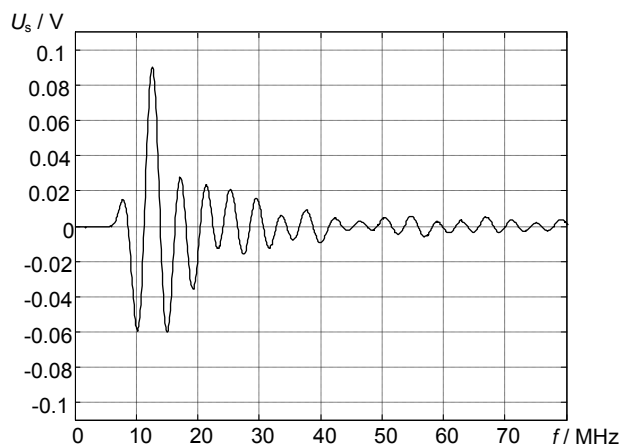

Fig. 8. The frequency response of the transmitter – receiver of the cube piezoelement with the matching layer

In the following part of the paper the cases when the piezoelement was acting as a receiver and the transmitter was broadband transducer are considered.

The investigation according to Fig. 4 was carried out and the obtained signal from the non-damped receiver is shown in Fig. 9, when the broadband transmitter was excited by 3 periods burst with the amplitude of 20 V. The amplitude of the ultrasonic signal was about 6 dB lower comparing with the amplitude when the transmitter was piezoelement (Fig. 5).

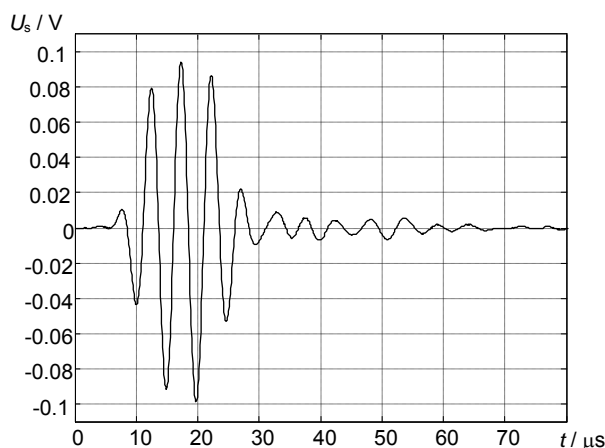

Fig. 9. Ultrasonic signal when the piezoelement was acting as the receiver

The shape of the pulse is close to the excitation pulse. It means that the piezoelement which has the dimensions 5×5×5 mm is acting also as the broadband receiver. The ultrasonic signals without matching layers and with matching layer (thickness of 1 mm) are shown in Fig. 10a and 10b. The shapes of pulses are very similar.

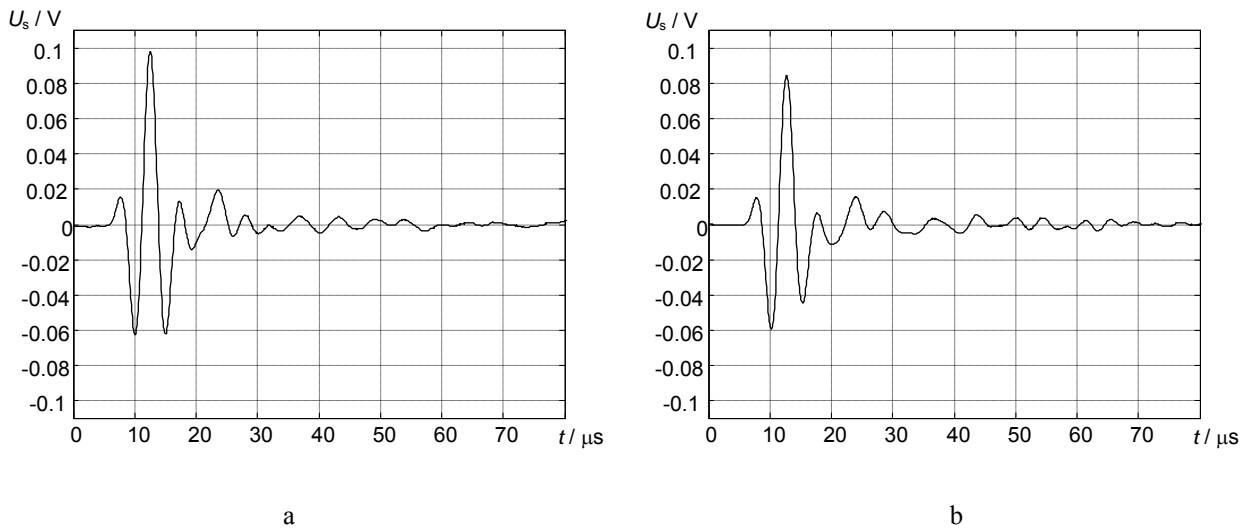

Fig. 10. The ultrasonic signals: a – without matching layer, b – with matching layer

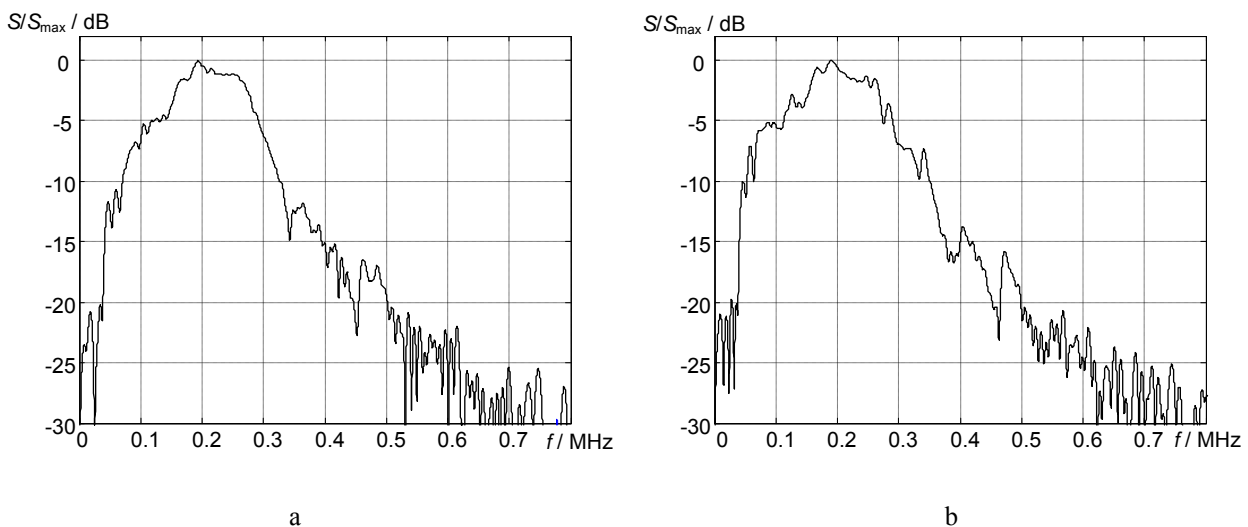

Fig. 11. The frequency response of the receiver-transmitter: a – the single cube (receiver), b – the cube (receiver) with the matching layer

The frequency responses obtained in these cases are shown in Fig. 11a and 11b. The non-damped piezoelement and the broadband transmitter give the wider frequency response in comparison with case when the non-damped piezoelement was used as transmitter (Fig. 6 and Fig. 8).

The frequency bandwidth at -6 dB is 200 kHz for both cases. It is very important for the contact type transducer because the thickness of matching layer during the mechanical scanning (friction) becomes thinner.

The experimental investigations show that the short ultrasonic pulse in the time domain and the broadband frequency response can be obtained using the non-damped piezoelement having lateral dimensions of the same size. It gives the possibility to create the new type of ultrasonic transducers which can operate in the long range ultrasonic technology and be used in the tasks of the structural health monitoring.

## Conclusions

The low frequency non-damped ultrasonic transducers for mechanical scanning systems were developed. The

non-damped piezoelement with dimensions of  $(5 \times 5 \times 5 \text{ mm})$  was used in the experimental investigations and modelling, the good agreement between the results was obtained.

The non-damped low frequency transducer operating as the transmitter gives higher amplitude by 12 dB than the broadband transducer. When the non-damped receiver is used, the amplitude of the received signal was higher by 6 dB.

The frequency response of the non-damped receiver is better (wider) than the frequency response of the transmitter. The bandwidth of the non-damped receiver was 200 kHz and does not change when the piezoelement is without matching layer and with matching layer having thickness of 1 mm.

## References

1. Kažys R., Demčenko A., Mažeika L., Šlīteris R. Air-coupled ultrasonic non-destructive testing of aerospace components. *Insight*. Vol. 49, No. 4. P. 1-5.
2. Demčenko A., Žukauskas E., Mažeika L. Air-coupled ultrasonic investigation of multi-layered composite materials. *Ultrasonics*. 2006. Vol. 44, Supp. 1. P. e819-e822.

3. **Stossel R., Krohn N., Pfeleiderer K., Busse G.** Air-coupled ultrasonic inspection of various materials. *Ultrasonics*. 2002. Vol. 40. P. 159-163.
4. **Raišutis R., Jasiūnienė E., Žukauskas E.** Ultrasonic NDT of wind turbine blades using guided waves. *Ultragarsas*. 2008. Vol. 63. No. 1. P. 7-11.
5. **Raišutis R., Jasiūnienė E., Šlitteris R., Vladišauskas A.** The review of non-destructive testing techniques suitable for inspection of the wind turbine blades. *Ultragarsas*. 2008. Vol. 63. No. 1. P. 26-30.
6. **Jasiūnienė E., Raišutis R., Šlitteris R., Voleišis A., Vladišauskas A., Mitchard D., Amos M.** NDT of wind turbine blades using adapted ultrasonic and radiographic techniques. *Insight*. Northampton: British Institute of non-destructive testing, ISSN 1354-2575. 2009. Vol. 51. No. 9. P. 477-483. [ISI Web of Science; COMPENDEX; INSPECT; 0,143].
7. **Brum K. K.** Evaluation of the quality of this fibre composites using immersion and air-coupled ultrasonic techniques. *ECNDT*. 2006. We.1.64. P. 1-8.
8. **Kažys R., Mažeika L., Barauskas R., Raišutis R., Cicėnas V., Demčenko A.** 2D analysis of interaction of Lamb waves with defects in loaded steel plates. *Ultrasonics*. 2006. Vol. 44. P. e11127-e11130.
9. **Mažeika L., Raišutis R., Maciulevičius A., Žukauskas E., Kažys R., Seniūnas G., Vladišauskas A.** Comparison of several techniques of ultrasonic Lamb waves velocities measurements. *Ultragarsas (Ultrasound)*. 2009. Vol. 64. No. 1. P. 11-17.
10. **Raišutis R., Kažys R., Žukauskas E., Mažeika L., Vladišauskas A.** Application of ultrasonic guided waves in non-destructive testing of defective CFRP rods with multiple delaminations. *NDT&E international*. 2010. No. 43. P. 614-624.
11. **Vladišauskas A., Raišutis R., Šlitteris R., Seniūnas G., Jankauskas A.** Investigation of the characteristics of the low frequency broadband contact transducers. *Ultragarsas (Ultrasound)*. 2010. Vol. 65. No. 3. P. 41-44.
12. **Ansys.** Theory reference for the mechanical APDL and mechanical applications. Release 12.1. Ansys Inc. 2009.
13. **Vladišauskas A., Šlitteris R., Raišutis R., Seniūnas G., Žukauskas E., Mažeika L.** Application of ultrasonic transducers for investigation of composite materials. *Ultragarsas (Ultrasound)*. 2009. Vol. 64. No. 4. P. 36-42.
14. **Vladišauskas A., Šlitteris R., Raišutis R., Seniūnas G.** Contact ultrasonic transducers for mechanical scanning systems. *Ultragarsas (Ultrasound)*. 2010. Vol. 65. No. 2. P. 30-35.
15. **Ultrasonic transducers.** Edited by Y. Kikuchi. Corona publishing company. Tokyo. 1969. P.424.
16. **Electroacoustical investigation methods of isotropic solids.** S. Sajauskas. Kaunas: Technology. 1994. P. 320.

A. Vladišauskas, E. Žukauskas, R. Šlitteris, R. Raišutis, G. Seniūnas

#### **Plačiajuosčių nedempferuotų ultragarsinių pjekozekitklių sukūrimas**

##### **Reziumė**

Sukurti nedempferuoti plačiajuosčiai žemojo dažnio pjekozekitkliai mechaniniams skenavimo įrenginiams. Sumodeliuoti 5×5×5 mm pjekozementai ir atlikti eksperimentiniai jų tyrimai. Gautieji rezultatai parodė, kad nedempferuoto siuntiklio atveju impulsinės modeliavimo charakteristikos atitiko eksperimentines impulsines charakteristikas. Nedempferuoto pjekozekitklio, dirbančio siuntimo režimu, signalas 12 dB didesnis, negu plačiajuosčio dempferuoto keitiklio, o dirbančio priėmimo režimu - 6 dB didesnis.

Plačiajuosčio nedempferuoto pjekozekitklio dažninė charakteristika turi platesnę dažnių juostą, kai jis dirba priėmimo režimu. Pjekozelemento be suderinimo sluoksnio ir su 1 mm storio suderinimo sluoksniu juostos plotis siekia 200 kHz, kai ultragarso signalo lygis 6 dB. Suderinimo sluoksnis sumažina ultragarso signalo amplitudę apie 10 %.

Pateikta spaudai 2010 12 13

DOI: 10.5755/j01.u.65.4.17166