

Estimation of sound power of centrifugal machines based on sound intensity measurements

D. Gužas, E. Jotautienė

Lithuanian Agricultural University

4324 Kaunas LITHUANIA, Phone: +370 7 296932, Fax.: +370 7 296932, E-mail: eglej@info.lzua.lt.

Introduction

If a sound power is determined from the measured sound pressure values quite significant errors are obtained.

We can define sound power also measure intensity (integrate the normal vector of the sound intensity over a surface enclosing the noise source).

Sound intensity is the average sound power, which is through unit of area. While measuring a sound intensity we do not take into account the reverberation sound from a reverberation surface and we can measure sound in the room with other noise sources. When we measure sound intensity we define direction of noise radiate and the influence of separate mechanisms of the machine on a total sound power level.

Method of investigation

Investigations of a sound intensity of a centrifugal machine were carried out in the measure using the compressor station "Mažeikių nafta". Scheme of measuring machines is presented in Fig. 1.

A sound intensity is measured using two microphones and a tape-recorder. Analysers with two channels are

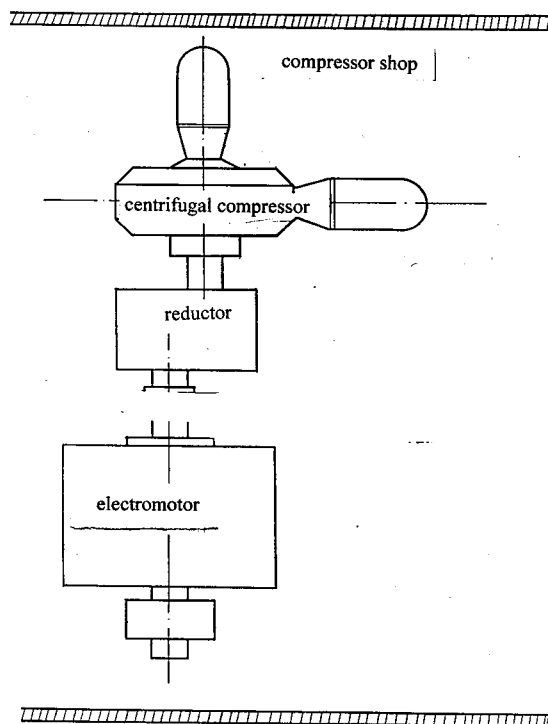

Fig.1. Scheme of measuring machines

stationary and have special operating for measuring sound intensity so we measure sound intensity in working place using tape-recorder for writing signals.

The principle of operation of the method of two microphones is described in detail in the work [1] and standards ISO 3740, ISO 9614. A frequency range in which we can measure depends on microphones and the spacing between two microphones.

The measuring surface, enclosing the source, can have any geometrical form. This means that the determination of sound power with the help of a sound intensity does not depend on a measuring surface. The number of measurement points depends on dimension of mechanism and on a required accuracy of a sound power.

Measuring method of sound intensity with the help of a tape-recorder is described in the "Brüel & Kjer" recommendation. According to this method the accuracy of an experiment depends on adjustment of a tape-recorder.

Measurement of sound intensity

For measuring sound intensity we used the measurement technique of "Brüel & Kjer", which contains the sound intensity probe type 3519, the two-channel microphone power supply type 2804 and microphone type 7005. The two-channel narrow band analyser type 1034 of the real time has measured the signal of a tape-recorder. This analyser has a special regime for measurement of a sound intensity. The measurement scheme is shown in Fig.2. The results of investigation were recorded on the graphic recorder type 2313.

The state of technique and the preparation for work corresponded to the recommendation of firm "Brüel & Kjer".

A sound intensity probe is based on two sets of phase-matched, free-field microphones in a face-to-face configuration. We used ½ inch microphones pairs and 6 mm microphone spacing between them. This enables us to make measurement with more accuracy in the frequency range from 31.5 Hz to 12.5 Hz

Sound intensity was recorded in four-time intervals (10 s) in all the measurement positions. A sound intensity probe was normal to the surface. The probe was turned at the angle 180° in the second interval in order to reduce phase mismatch.

Then we changed the microphone frame (microphones and microphone spacing) and we repeated recording of the sound intensity in two intervals. This number of intervals is required for precise sound power definition in the frequency band.

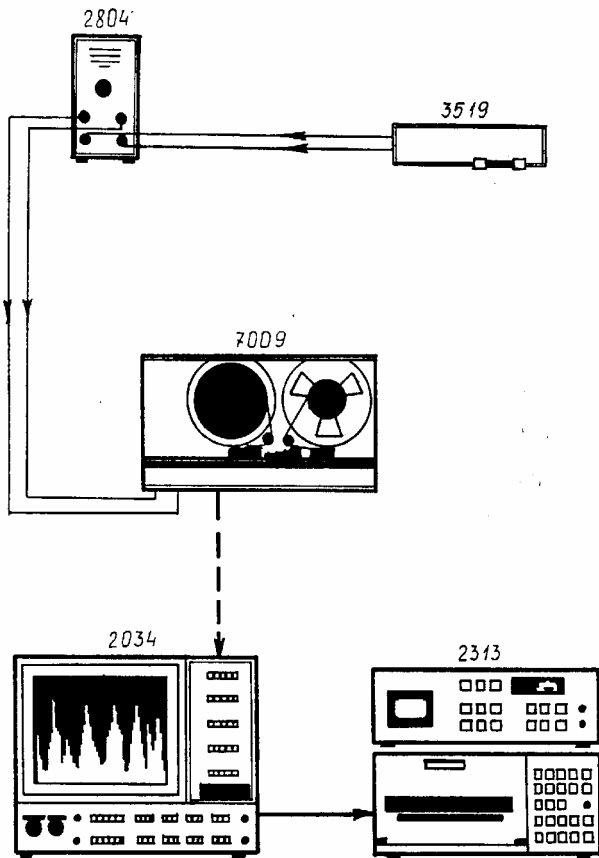

Fig.2. The measurement scheme.

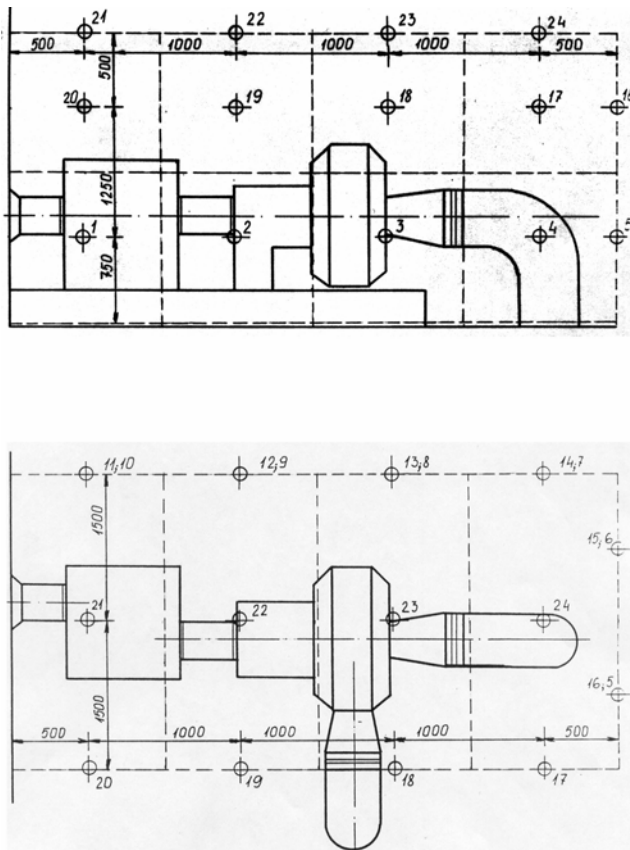

Fig.3. Scheme of measuring points.

The best surface for measurement is parallelepiped. It was divided in to 24 parts and we measured a sound intensity for all these parts. The scheme of measuring points on the surface is presented in Fig.3.

The results of sound intensity measurements are presented in Fig. 5-7. The first diagram shows the average sound intensity at all measuring points. The diagram in Fig.5-7 shows sound intensity at the points 7 and 2.

Using sound intensity measuring to determine sound power level

A radiated sound power of mechanism may be described in the following form:

$$P = \int_A I_n dA, \tag{1}$$

where I_n is the sound intensity in the direction n , which was normal to the area element dA ; A is the surface area.

In accordance with Eq. 1, the area of measuring surface may be divided into parts and used to determine the sound power of every part. Later we can find the total sound power level.

Sound power of i -th part of the surface in the octave frequency range is given by:

$$P_i = I_{ni} A_i, \tag{2}$$

where I_{ni} is the sound intensity of i -th surface, A_i is the i -th surface area.

The total sound power level we find from equation:

$$L_W = 10 \lg \sum_{i=1}^n P_i / P_0, \tag{3}$$

where P_i is the sound power of the surface of i -th part; P_0 is zero level of sound power (10^{-12} W). The power of the centrifugal machine radiated in octave frequency range is presented in Fig.4.

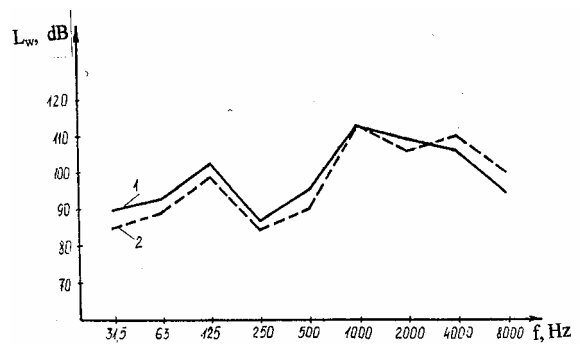

Fig.4. The spectra of sound power level: 1-measuring sound pressure level; 2-measuring sound power level.

Analysis of results

The analysed methods were investigated in real conditions.

The power of centrifugal machine radiated in a octave frequency range determined from sound intensity measurements is presented in Fig.4.

The sound pressure and intensity were measured in the same work regime of the centrifugal machine.



Type 2034

Plot Time
90-04-12
10:32:13

Page No.: 1
Sign.: _____

Measuring Object: _____

Comments: _____

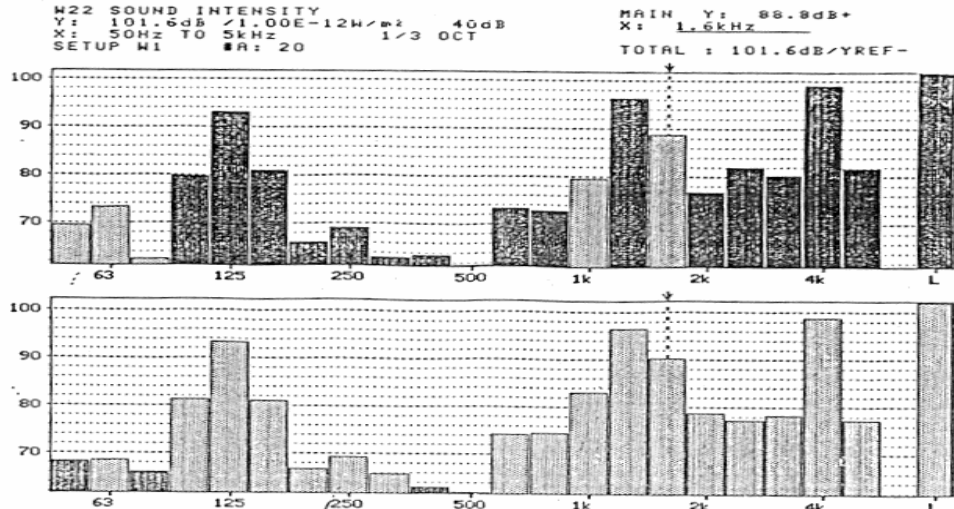

Type 2034

Plot Time
90-04-24
10:23:22

Page No.: 2
Sign.: _____

Measuring Object: _____

Comments: _____

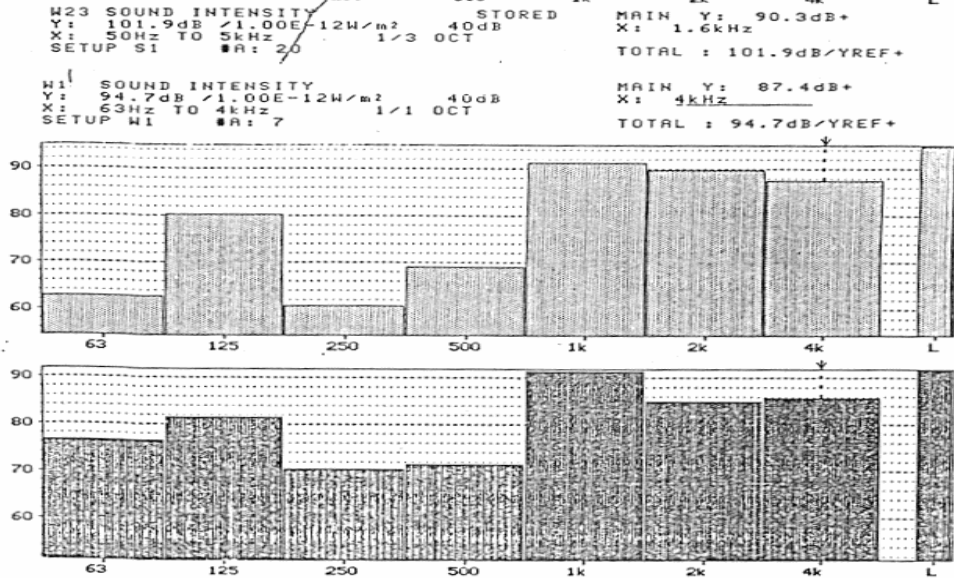

Type 2034

Plot Time
90-04-24
12:14:37

Page No.: 4
Sign.: _____

Measuring Object: _____

Comments: _____

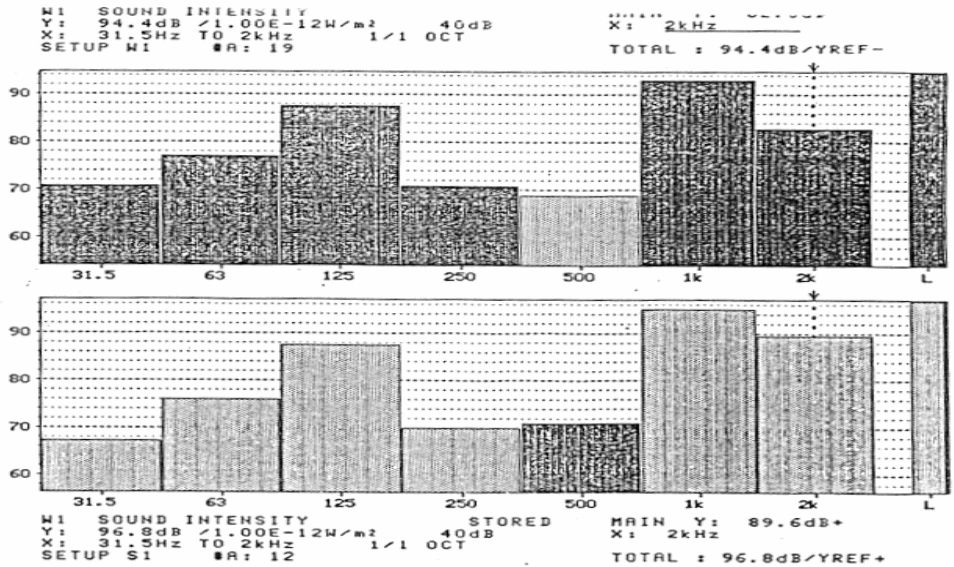

Fig.5. The diagrams of sound intensity

From the diagrams we can see that the character of radiated power spectra was the same. At 125 Hz frequency the rotation frequency of a reductor shaft has increased. The frequency of pump blades was 1-2 kHz.

The measurement of sound intensity shows that the sound intensity was higher at in the points 1, 10, 12, 19, 20 and it was minimal in the point 21 (Fig. 5) because the reductor had a biggest influence on the total sound power level and the radiated sound energy was directed up.

We get maximum of sound the intensity level at the points 3, 8, 13, 18, and 23 because the pump created a high level of sound power in the 1000-4000 Hz frequency range. The sound radiation is directed from centrifugal machine body to pipes. It should be noted that it is very difficult to define it, when we measured a sound pressure level.

Conclusions

Sound power level is the main characteristic when we want to determine noise of machine and we made acoustic calculation. From the measurement results we see, that using the method of sound intensity for definite sound

power in real conditions we get exactly results as in the case of sound pressure level methods. When we measure a sound intensity we define direction of noise radiated and the influence of separate mechanisms of machine on a total sound power level, what is very important for reduction of a noise.

References

1. **Yang S. J., Ellison A. J.** Machinery Noise Measurement. Oxford University Press, 1985.

D. Gužas, E. Jotautienė

Išcentrinių mašinų garso galios nustatymas matuojant intensyvumą

Reziumė

Darbe rotorinių mašinų garso galia nustatyta matuojant jo intensyvumą. Matavimai buvo atlikti įmonės "Mažeikių nafta" kompresorinėje. Intensyvumas buvo matuotas pagal "Brul & Kjaer" firmos rekomendacijas, naudojant dviejų mikrofonų garso intensyvumo matavimo zoną. Remiantis garso intensyvumo matavimų rezultatais, apskaičiuota rotorinių mašinų spinduliuojamo triukšmo garso galia (W). Iš rezultatų matome, kad natūraliomis sąlygomis mechanizmų garso galios lygis intensyvumo metodu, nustatomas tiksliau nei įprastiniais garso slėgio lygio metodais.

DOI: 10.5755/j01.u.31.1.7917