

Directivity characteristics of ultrasonic transducers for flow measurements

A.Vladišauskas

Ultrasound Institute

Kaunas University of Technology

Introduction

Ultrasonic methods are widely used for measurement of the flow velocity of liquids and gas [1-4]. Possibilities and accuracy of this method depend on characteristics of the ultrasonic transducers which usually break up into groups: the clamp-on and the wetted transducers. The clamp-on transducers are used only for measurements of the flow velocity of liquid. They mounted on the external wall of the pipe and as a result complicated acoustical channel is obtained [5,6]. Direction and parameters of the ultrasound beam in the clamp-on methods depend on directivity pattern of the transducer, angle of a wedge, material of the pipes walls, material of the wedge and so on.

The wetted transducers use to measure of the flow velocity in liquids and gas. The transducers designed for applications in liquid can hardly be used in gas because the amplitude of the radiating surface is comparatively small. The reason of this is the large impedance mismatch between gas an active element of the transducers. Also, in the gas, we have high losses due to attenuation and a turbulence. An additional problem in the measurement of the gas flow is the sweeping of the ultrasonic beam. It means that the main part of the ultrasonic beam could be sweep away from the receiving transducer by the flow. As a result will be loss of signal and a serious reduction in the signal-to-noise ratio. Reducing the size of the transducers would reduce their directionality and the effect of beam sweep. However it also reduce the energy of the beam in any one direction.

The work reported in this paper is concerned the directivity characteristics of the wetted transducers such as a directivity pattern of the transducers and a carry away ultrasound beam by the flow also an influence of the flow on the directivity pattern. They are important and determine the measurement range of the flow velocity.

Results of research

Possibilities of the gas flow measurements are determined of gas medium which have the low ultrasound speed and the high attenuation loss. The low ultrasound speed is good for measurement of the ultrasonic waves transit time. However the long transit time causes the carry away of the ultrasound beam and changes directivity.

In many different gas the ultrasound speed changes slightly (see Table 1). The deviation of the ultrasound speed is about $\pm 20\%$ from average speed value. Then the main characteristics of the gas transducers such as a sensitivity and a directivity pattern are rather similar. The

width of the directivity of the gas transducers (in level – 6dB) can be calculated from equation

$$\theta_{0,5} = \arcsin 0,72\lambda / d, \quad (1)$$

here λ is the ultrasonic wavelength in the gas, d is the diameter of the transducer.

Table 1. Ultrasound speed in gas

No.	Gas	t (°C)	c, m/s	$\left[\frac{dc}{dt} \right]_{t=0}$
1	Air	0	331	0.6
2	Nitrogen	0	333	0.85
3	Argon	0	319	-
4	Methane	0	430	0.62
5	Neon	0	435	0.78
6	Water steam	100	405	-
7	Ethane	0	308	-
8	Ethylene	0	317	0.56
9	Oxygen	0	314	0.57

In the investigations of the acoustic fields is convenient to change wavelength to frequency according following expression

$$\lambda = c / f, \quad (2)$$

here c is the ultrasound speed, f is the frequency.

Than we get

$$\theta_{0,5} = \arcsin 0.72c / f \cdot d. \quad (3)$$

The width of the directivity pattern in air and methane gas where calculated (Fig.1). A diameter of the transducer

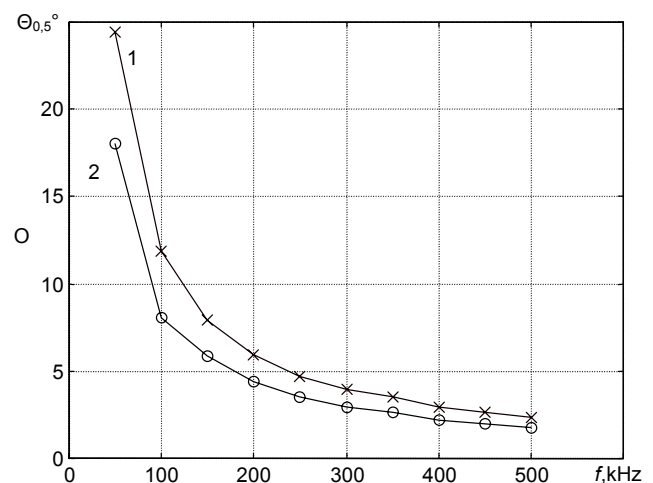

Fig.1. Width of the directivity patterns of the transducer: 1 – methane gas; 2 – air

was accepted $d=15$ mm and as a lower limit of frequency 50 kHz. This frequency gives the largest angle of the directivity pattern however to utilize this one is difficult. An accuracy of measurement and an acoustical noise channel through the walls of the pipe makes low frequency rarely use in practice. Therefore high frequencies are desirable. However, in this case, the half of the directivity pattern will be only 2-3 degree (Fig.1, 400-500 kHz). At high frequencies the different between the directivity patterns in air and in methane gas is insignificant.

The configuration of the acoustic channel is important for assurance normal operating of the gas meter. The acoustic channel for oblique incidence is schematically represented in Fig.2. The acoustical axes of the transducers 2 and 4 coincide when the flow is equal zero. A propagation distance of the ultrasound waves in the inside of pipe is l_0 . A projection of the propagation distance on the inside wall will be z_0 .

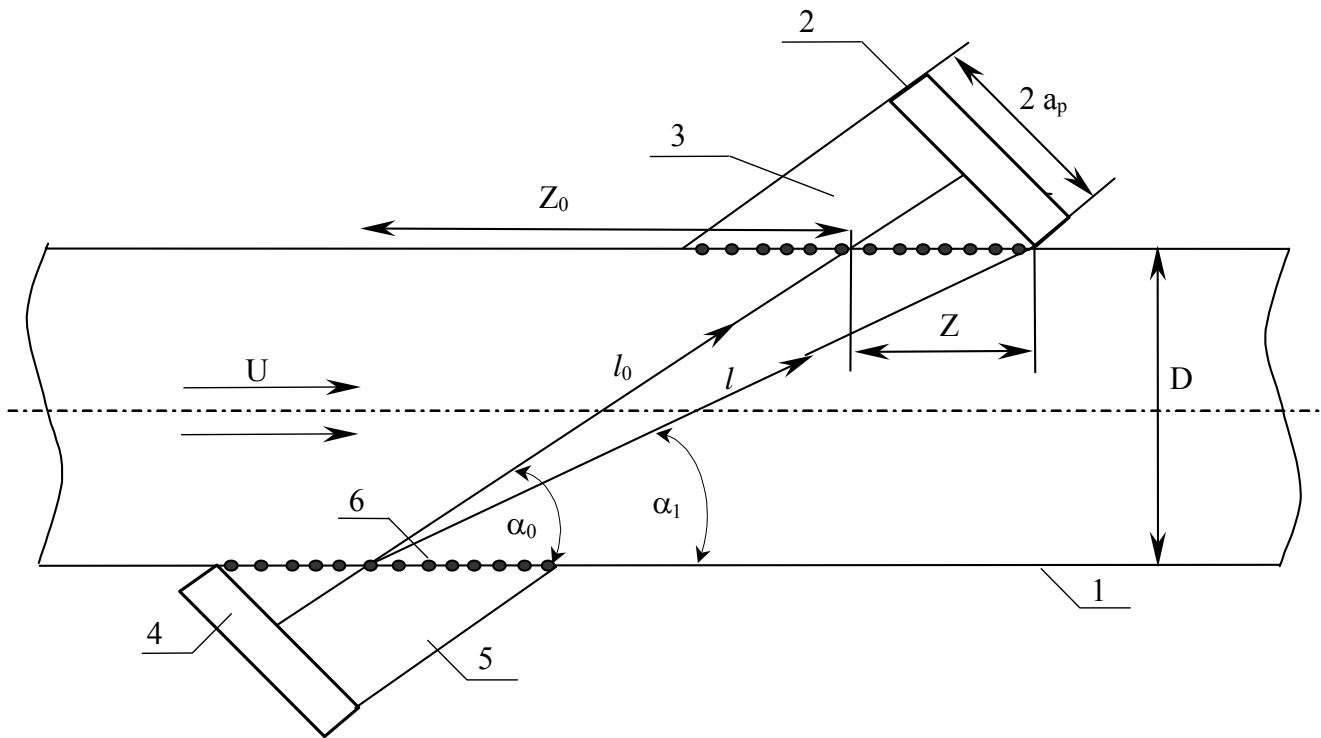

Fig.2. Schematic representation of the acoustic channel: 1-inside surface of the pipe; 2-4 – transducers; 3-5 – recesses of the transducers; 6 - net

An inside diameter of the pipe – D . Then an angle between of the direction ultrasonic waves propagation and an axis of the pipe will be

$$\operatorname{tg} \alpha_0 = D / z_0 \quad (4)$$

The time of the ultrasound waves propagation

$$\tau = l_0 / c. \quad (5)$$

When flow exist the beam of ultrasound move along the direction of flow. The distance of the ultrasonic waves propagation will be l . Let take that the flow in the recesses of transducers is zero, because the recesses are separated by a net. A lengthening in an axial direction (see Fig.2)

$$z = u \cdot \tau_q \quad (6)$$

here u is the velocity flow.

An new angle

$$\operatorname{tg} \alpha_1 = \frac{D}{z_0 + z}. \quad (7)$$

From Eq.4, 6 and 7 we shall get

$$\operatorname{tg} \alpha_1 = \frac{D}{D / \operatorname{tg} \alpha_0 + u \tau}. \quad (8)$$

Two ultrasonic transducers 2 and 4, which work alternately as transmitter and receiver, transmit ultrasonic waves upstream and downstream across the flow in the tube. Then the superposition of ultrasound speed and flow velocity gives the two angles

$$\operatorname{tg} \alpha_1^{\pm} = \frac{D}{D \operatorname{ctg} \alpha_0 \pm u \cdot \tau}. \quad (9)$$

An upstream angle α_1^+ will be more than angle α_0 , another angle (downstream) α_1^- will be smaller that one.

From the Fig.2 we can write

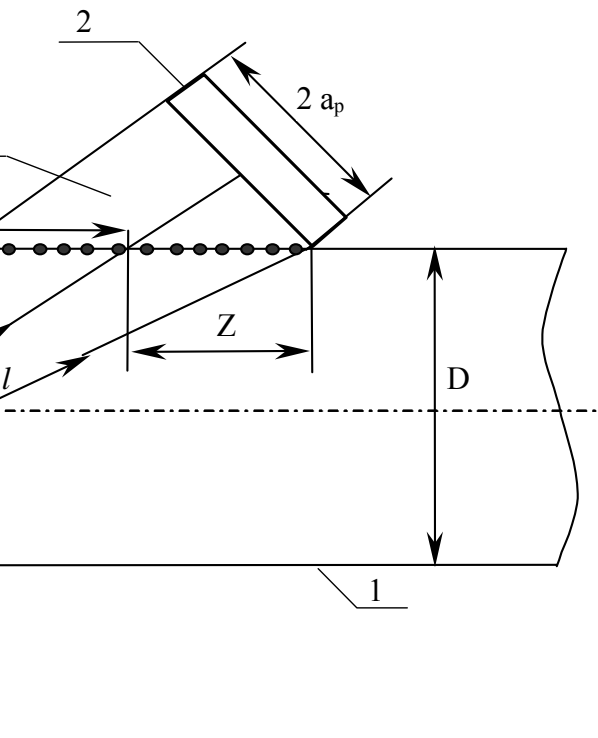

$$D = l_0 \sin \alpha_0 \quad (10)$$

and inserting 5 and 10 in the Eq.9, we obtain

$$\alpha_1^{\pm} = \arctg \left[\frac{c \sin \alpha_0}{c \cos \alpha_0 \pm u} \right]. \quad (11)$$

This expression shows that value of the upstream and downstream angles depend on the primary angle, ultrasound speed and flow velocity.

The maximum value will be if $\alpha_0' = 90^\circ$

$$\alpha_1^M = \arctg \frac{c}{\pm u}. \quad (12)$$

The difference of the upstream and downstream angles

$$\Delta \alpha_1^{\pm} = \arctg \alpha_0 - \arctg \left[\frac{c \sin \alpha_0}{c \cos \alpha_0' + u} \right], \quad (13)$$

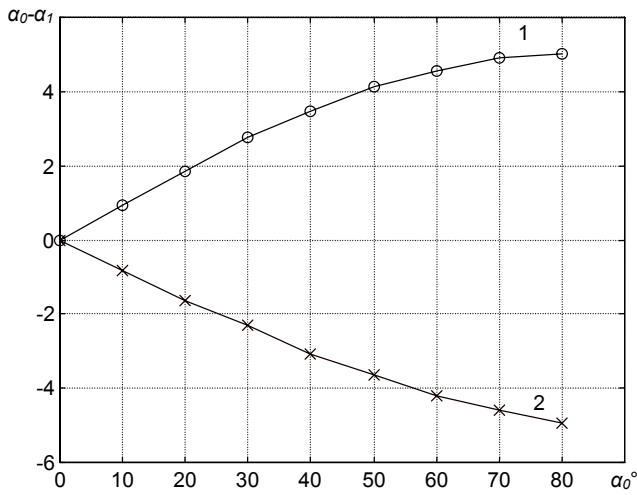

Fig.3. Dependence of the upstream and downstream angles from primary angles: 1-upstream; 2 - downstream

$$\Delta\alpha_1^- = \arctg\alpha_0' - \arctg\left[\frac{c \sin \alpha_0'}{c \cos \alpha_0 + u}\right] \quad (14)$$

This difference can be evaluated according to the primary angle α_0 and of the flow velocity. The calculation results from the primary angle are shown in Fig.3. The velocity of air flow was accepted constant and equal 30 m/s. The difference of the upstream angle is more than the difference of the downstream angle. It means that the directivity pattern of the transducers will be carry away diversely and the amplitudes of the ultrasonic signals in the upstream and downstream measurement channel also will be not equal. The insignificant difference of the angles is at the small primary angle ($\alpha_0 = 0^\circ-10^\circ$) or large ($\alpha_0 = 70^\circ-80^\circ$). At the middle range ($\alpha_0 = 30^\circ-50^\circ$) the difference between upstream and downstream is about 0.3-0.45°.

If the parameters of transducer are incorrectly choose carry away of the ultrasound beam can be more than a width of the directivity pattern.

If a distance of the ultrasound waves propagation is the same for different angles (the distance between two transducers in the measurement path is constant), than two factors decide carry away of the ultrasound beam. The

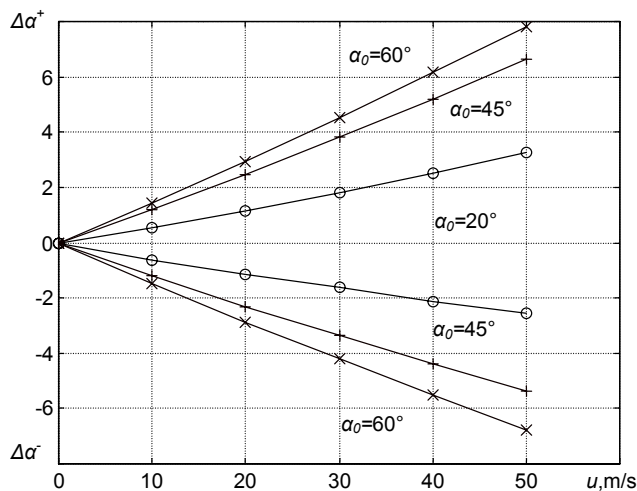

Fig. 4. Dependence of the difference of angles from the velocity of flow and the primary angle

calculated results of the angles changes are depicted in Fig.4. It should be noted, that the velocity of flow is determinant in the carry away of ultrasound beam, because it has more wide range.

The carry away of ultrasound beam in the measurement path can be calculated from the next formulas

$$z = \frac{u \cdot l_0}{c}, \quad (15)$$

$$l_0 = D / \sin \alpha_0. \quad (16)$$

Inserting 16 in the Eq.15, we obtain

$$z = \frac{u \cdot D}{c \cdot \sin \alpha_0} \quad (17)$$

In this case the carry away of ultrasound beam also depend on the diameter of pipe. If the primary angle $\alpha_0=45^\circ$, Eq.17 we can simplify

$$z = 1.41 \frac{u \cdot D}{c} \quad (18)$$

As was mentioned the ultrasound speed in gas is small. Then the distance of the carry away is large.

From Fig. 2 we find

$$a_p = z \cdot \sin \alpha_0, \quad (19)$$

here a_p is a radius of transducer.

Because was accepted that the velocity of flow in the recess of transducer equal zero, than the ultrasound beam in the recess don't changes the direction. Inserting Eq. 19 in the Eq. 17 we obtain

$$a_p = \frac{u \cdot D}{c} \quad (20)$$

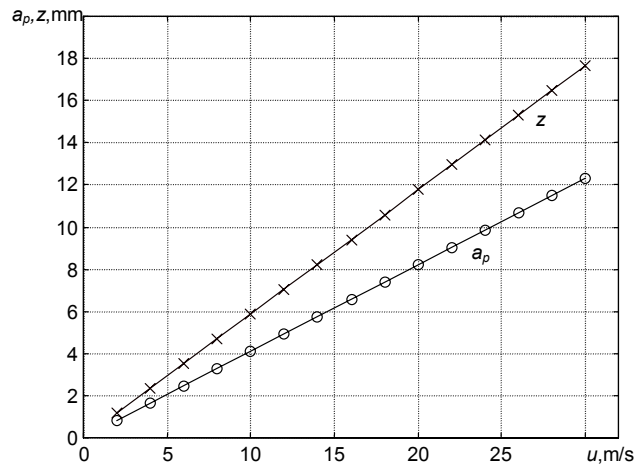

Fig. 5. The carry away of the ultrasound beam from the flow velocity in air

The radius of transducer can be accepted as the carry away of the ultrasound beam across a surface of the receiving transducer. According to Fig. 2 the distance z is the carry away of the ultrasound beam to the direction of flow. The results of calculation (Fig. 5) where performed for the air flow in the pipe with diameter 140 mm. The radius of transducer was accepted 6 mm and primary angle 45° . If we have the flow velocity 10 m/s the carry away of the downstream ultrasound beam will be 5.8 mm along the direction of the flow and 4.1 mm across the surface of the receiving transducer. From the dependence of the carry

away of ultrasound beam and the directivity pattern of transducer we can evaluate the value of ultrasonic signal.

Conclusions

The difference of the directivity pattern width (from transducer acoustic axis) according to flow direction in the upstream and downstream measurement channel determines the unequal values of ultrasonic signal. In the downstream channel the amplitude of ultrasonic signal is larger than in the upstream channel. If the distance of the ultrasound wave propagation is constant, the difference of the ultrasonic signals in the upstream and downstream measurement channel depends on primary angle and flow velocity.

References

1. **Lynnworth L.C.** Ultrasonic flowmeters. /Physical acoustic. New York: Academic press. 1979. P.408-520.
2. **Хамидулин В.К.** Ультразвуковые контрольно-измерительные устройства и системы.-Ленинград: Ленинградский университет. 1989. 220 с.
3. **Spitzer D.W.** Flow measurement: Practical guides for measurement and control. /Instrument society of Amer. USA. 1993. P. 611.
4. **Walus S.** Przerlywomierze ultradźwiękowe metodika stosowania. – Wydanstwo politechniki śląskiej. Gliwice, Polska. 1997. P.152.
5. **Funck B., Mitzkus A.** Acoustic transfer function of clamp – on flowmeter. /IEEE Transactions on ultrasonic, ferroelectrics and frequency control. 1996. Vol 43. No.4. P.569-574.
6. **Vladišauskas A.** Analysis of the wave propagation in the electroacoustic channel of the ultrasonic clamp – on flow meters. /Ultragrāsas. Kaunas: Technologija. 1997. No.2(28). P.20-22.

A.Vladišauskas

Ultragarsinių keitiklių, skirtų srautui matuoti, kryptingumo charakteristikos

Reziumė

Straipsnyje nagrinėjamos ultragarsinių keitiklių kryptingumo diagramos dujos ir ultragarso spindulio nuėsimas sraute. Pateiktos matematinės išraiškos ir skaičiavimai parodo, kad pjūvkeitiklio kryptingumo diagramos plotis (nuo akustinės ašies) srauto tekėjimo kryptimi yra nevienodas. Todėl ultragarso signalo amplitudės matavimo kanaluose prieš srautą ir pagal srautą bus skirtingos. Ultragarso signalo amplitudė prieš srautą bus mažesnė už ultragarso signalo amplitudę pagal srautą. Šis skirtumas priklauso nuo kampo tarp ultragarso bangų sklaidimo krypties ir srauto. Taip pat nuo srauto greičio. Srauto greitis vaidina lemiamą rolę kaip ultragarso spindulio nuėsimui, taip ir ultragarso signalui matuoti kanaluose.

Pateikta spaudai: 2001 05 8

DOI: 10.5755/j01.u.39.2.8054