

Experimental investigation of gas flow profiles in ultrasonic flow meters

R. Kažys, A. Vladišauskas, R. Raišutis

Prof. K.Baršauskas Ultrasound Institute

Kaunas University of Technology

Introduction

Ultrasonic gas and flow rate measurements are widely used in industrial and domestic applications [1-3]. Performance of ultrasonic flow meters was significantly improved exploiting acoustical measurement channels of different modifications, such as with multiple reflections of ultrasonic signals in a pipe, optimisation of the orientation angle of transducers with respect to the flow direction or application of multichannel measurement systems [4, 5]. In all these cases high accuracy of measurements in a wide range of flow velocities is obtained when peculiarities of interaction of ultrasound waves with a gas flow are taken into account. For that purpose it is necessary to know flow velocities profiles in the region where the acoustical measurement channel is located, taking into account the influence of recesses in the pipe, which are used to mount ultrasonic transducers. These recesses influence symmetry of the flow profile along the ultrasonic path, but probably do not affect the profile of the flow outside this region. If the total flow rate is calculated from the ultrasonic measurement data not taking into account the local character of the profile distortions, then additional measurement error may occur. Therefore, the knowledge of the flow velocity profiles in the measurement section of ultrasonic meters is very essential, when a high accuracy of measurements must be achieved in a wide range of flow velocities.

The objective of this research was experimental investigation of gas flow velocities profiles in the acoustical cylindrical measurement channel of an ultrasonic flow meter using miniature invasive flow sensors such as a thermo anemometer and an air velocity meter.

For such an investigation it was necessary to estimate performance of the sensors at different orientation angles of the sensors with respect to the flow and to develop method and experimental equipment for measurement of directivity patterns of invasive sensors inside the real pipe. In order to perform the measurements inside the pipes, it was necessary to develop the special equipment and measurement methods. The flow profile measurements were performed both across the cylindrical pipe and along the path of an ultrasonic beam, including the areas in a close vicinity of the recesses in which ultrasonic transducers are mounted.

Investigation method

Measurements of gas flow profiles are complicated, because intrusive sensors distort the flow velocity profile. Optical methods are non-invasive, however the

measurement section must be optically transparent and equipment is suitable only for laboratory investigation [6]. Therefore, it was decided to perform velocity profile measurements with miniature invasive thermo anemometer. Usually during measurements anemometers are oriented vertically with respect to the flow direction. However, when the anemometer is placed in the flow, it distorts the flow profile, particularly in smaller diameter pipes, due to the bar like housing. Hence, first of all it was necessary to investigate performance of the thermo anemometer in a flow at various orientation angles and to find out the ways to reduce measurement errors caused by non-symmetrical distortions of the flow profile caused by the thermo anemometer itself.

In this investigation the microprocessor measurement unit ALMEMO 2280-8 with two sensors was used. Those sensors were the thermo anemometer d2.60 (measurement range 0-2 m/s) and the air velocity meter S140 (flow measurement range 0-40 m/s). Dimensions of both sensors are shown in Fig.1. The air velocity meter was used as the reference meter to measure an average flow velocity at the centre of the pipe (Fig.2). Measurements of gas flow profiles were performed with the thermo anemometer.

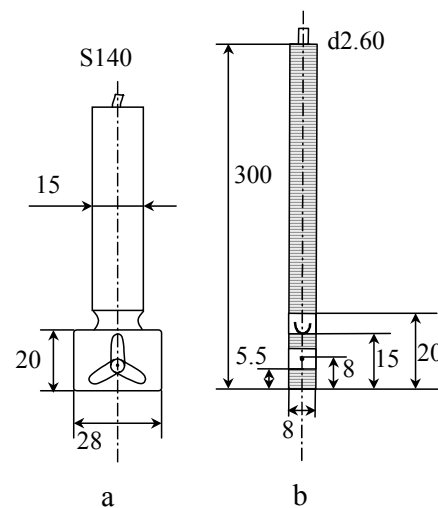

Fig.1. Sensors of the microprocessor measurement unit: a – air velocity meter, b - thermo anemometer

The thermo anemometer was used for local flow velocity measurements along the diameter. The length of its bar like housing (300 mm) allows to perform measurements in the pipes up to 100 mm diameter in different directions. The sensitive element of the thermo anemometer is placed inside the cylindrical hole with the

diameter 5 mm, the centre of which is located 5 mm from the tip of the housing. The diameter of this cylindrical hole restricts a spatial resolution of local flow measurements. On the other hand such geometry of the thermo anemometer makes impossible to perform measurements in a close vicinity of the pipe wall.

In order to get a complete velocity profile along the acoustic path, the real ultrasonic transducers were replaced by mock-ups, in the centre of which the cylindrical holes were made. The thermo anemometer was pushed through the holes and in this way the velocity profile was measured. When the measurements of a flow velocity are performed along the acoustical path, e.g. at some angle to the flow direction, then the shortest distance to the pipe wall at which measurements may be carried out is given by

$$s = \frac{\phi_s}{2} \cos \alpha, \tag{1}$$

where ϕ_s is the diameter of the thermo anemometer's hole in which the sensing element is mounted, α is the angle between the longitudinal axis of the thermo anemometer and the pipe axis.

Close to the hole with a flow sensor there is the second 5 mm diameter hole with a thermometer. This hole may distort a flow profile, therefore in the case when temperature measurements are not necessary, this hole may be covered.

Schematic presentation of the measurement equipment used for investigation of flow velocity profiles is given in Fig.2.

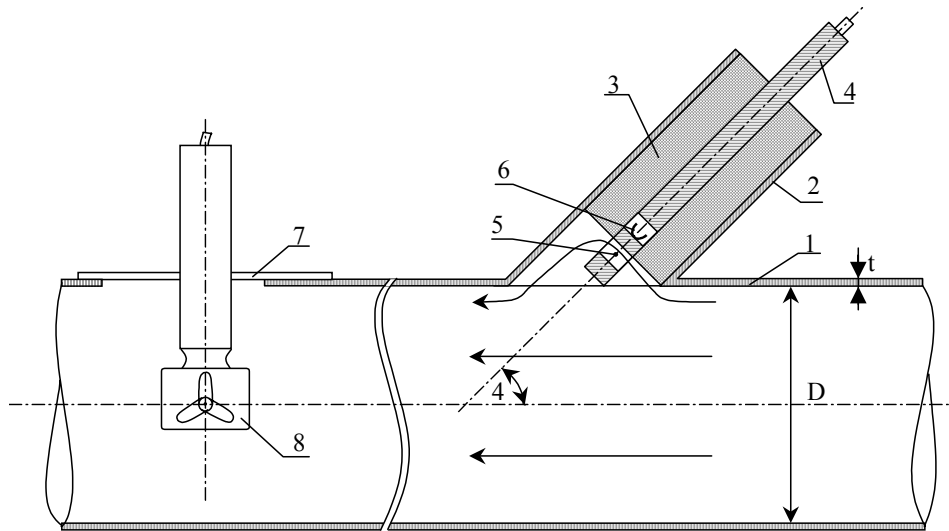

Fig.2. Experimental arrangement for measurement of gas flow profiles: 1-plastic pipe; 2-mount of the transducer; 3- transducer mock-up; 4- housing of the thermo anemometer; 5-flow sensing element; 6-thermometer;7-segment of pipe; 8-air velocity meter

This measurement set-up consists of a plastic (PVCH) DN70 pipe, recess of the ultrasonic transducer, transducer mock-up, the thermo anemometer d2.60, sensing element of the flow, thermometer, pipe section 7 to cover the hole for the air velocity meter, the air velocity meter S140. In order to perform measurements of a gas flow velocity in an acoustical channel in the transducer mock-up the hole is drilled through which the thermo anemometer is scanned. The centre of the hole coincides with the acoustical axis of the ultrasonic transducer. To avoid leakage of gas the mock-up of the transducer fills the recess completely. The position of mock-up in the recess is variable; the front surface coincides with the front surface of the transducer.

Character of a flow depends on the Reynolds number:

$$Re = \frac{\rho \cdot D \cdot v}{\mu_D} \tag{2}$$

where ρ is the density, D is the inner diameter of the pipe, μ_D is the dynamic viscosity, v is the flow velocity. In the range of the Reynolds numbers $Re < 2000$, the flow is laminar, and for $Re > 4000$ the flow is turbulent. In the

intermediate zone $2000 < Re < 4000$ the flow is called transitional.

Calculated values of the Reynolds number in the range for airflow velocities (0-3) m/s and pipe diameters from

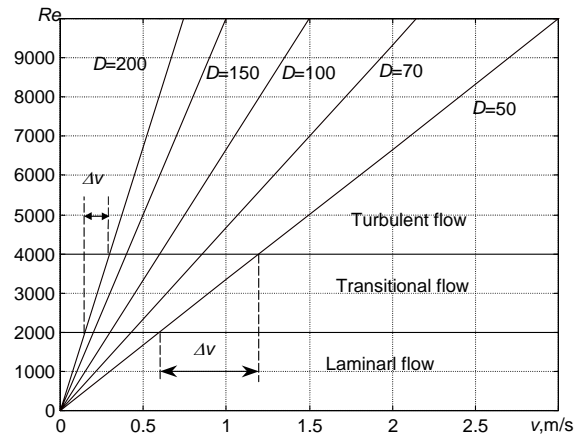

Fig.3. Reynolds number versus a flow velocity for different diameter pipes

50mm up to 200 mm are presented in Fig.3. The horizontal straight lines denote the zones of laminar, transitional and turbulent flows. At higher flow velocities and wider diameters only turbulent flows may exist. From the presented results follows that for the pipe with diameter $D=70\text{mm}$, used in the measurement stand, and for the velocities $v>1\text{m/s}$ flows may be only turbulent. Therefore, majority of the results obtained in this investigation are valid for turbulent flows, which are mainly used in various applications

Investigation of directivity properties of thermo anemometer

During flow profile measurements axis of the hole of the thermo anemometer in which the sensor is placed, may not coincide with the direction of a flow velocity vector. Such a situation is met when flow profile measurements are carried out along the acoustic path, which usually is at 45° with respect to the pipe axis. In this case it is not obvious how the measurement results can be affected by such misalignment. Performance of the thermo anemometer may be characterised by directivity patterns in two perpendicular planes. One plane is perpendicular to the axis of the anemometer housing and this directivity pattern is called axial; the second plane coincides with the axes of the housing and the flow measurement hole and the corresponding directivity pattern is called angular. The directivity patterns describe dependence of the signal at the output of the meter at different angles between the flow vector and the axis of the hole. From the point of a view of measurements wider directivity patterns are more preferable, because in this case it is possible perform measurements along various paths oriented at different angles to the flow direction.

Schematic presentation of the experimental arrangement for measurement of anemometer angular directivity pattern is shown in Fig.4.

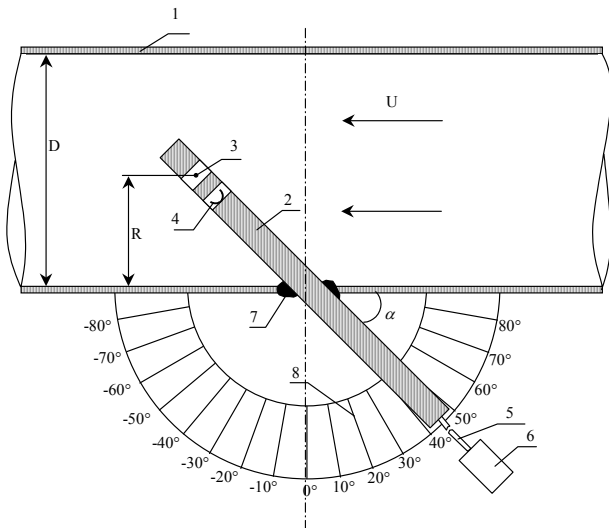

Fig.4. Experimental setup

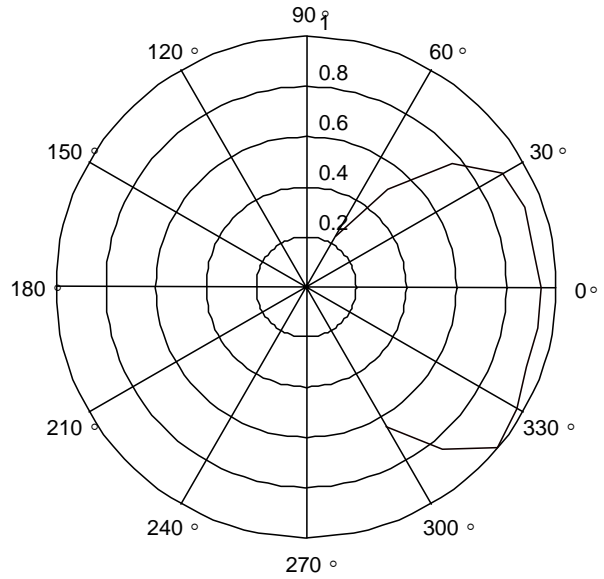

Fig.5. Angle directivity pattern of thermoanemometer

Flow measurements are performed in the pipe 1 in which the anemometer 2 is placed. The flow sensing element 3 and the temperature-sensing element 4 are located in the corresponding holes. Orientation of the housing and holes in the flow may be changed, because the housing is connected to the pipe wall with a flexible muff 7. The orientation angle is measured by means of the scale 5. The anemometer via connector 6 is connected to the microprocessor measurement unit. During measurements of the directivity patterns, the flow sensing-element was positioned at the centre of the pipe. The rotation of the anemometer in any of the two perpendicular planes was performed in such a way that the sensing-element was kept at the origin of a polar coordinate system. In the case of the angular directivity pattern that required to readjust an insertion depth of the anemometer into the pipe.

Measurement results of the angular directivity pattern are shown in Fig.5. As we can see, that angle directivity pattern is asymmetrical, what is caused by position of the sensing- element in the anemometer's hole. Width of the directivity pattern at the -6 dB level is 107° .

The measurements of the axial directivity pattern (Fig.6) were performed in the pipe 1, exploiting a special mounting system 2 with the thermo anemometer housing 3 perpendicular to the pipe's wall. The thermo anemometer was positioned in such a way that flow sensing-element would be inside the pipe. To ensure symmetry of the flow a compensation bar 6 with the same dimensions as of the thermo anemometer housing 3 was used. Measurement results are presented in Fig.7. Axial directivity pattern is asymmetrical too. From the results obtained follows that directivity of the thermo anemometer in two perpendicular planes is different.

Optimisation of measurement method

In fact, the presence of the meter inside the pipe distorts the flow velocity profile, causing additional and turbulent phenomena like an aerodynamic wake. The cylindrical anemometer's housing of a finite length is creating asymmetry of the flow in the area where measurements are performed. Therefore, in order to determine how significant these distortions are and also it is possible to reduce them, experimental investigations were carried out. During these experiments flow velocity profiles in the straight cylindrical pipe were measured by the conventional anemometer described above and by a modified anemometer to which an additional compensation rod was attached (Fig.8). The main idea of this approach is that the anemometer with the compensation rod still distorts profile, but these distortions are less and symmetrical with respect to the pipe axis.

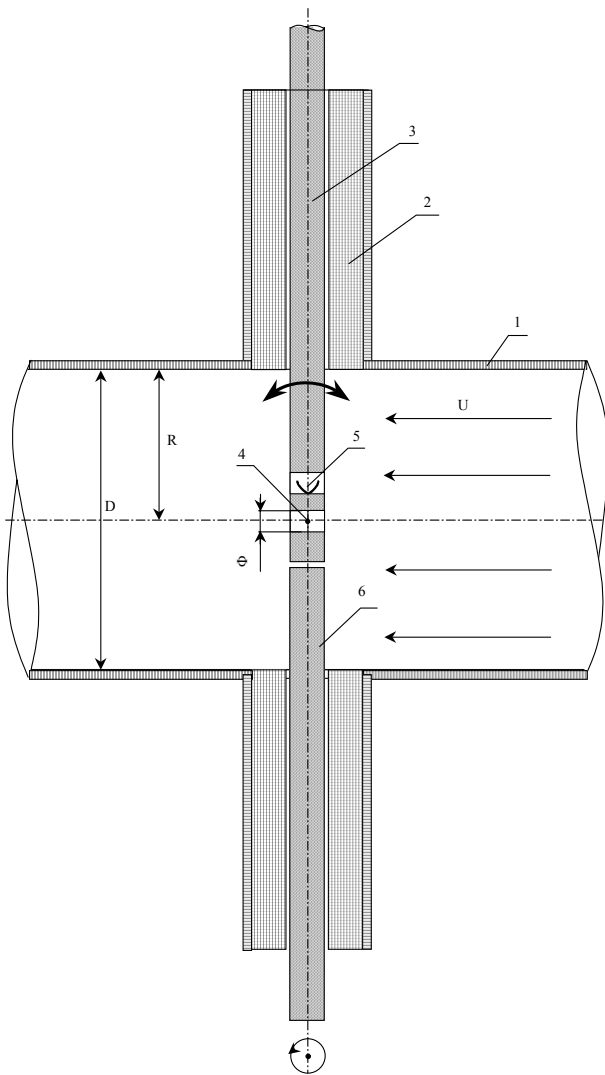

Fig.6. Experimental arrangement for measurement of the axial directivity pattern: 1- pipe, 2- mounting system of the transducer with the mock-up of an ultrasonic transducer, 3- housing of the thermo anemometer, 4- flow-sensing element, 5- thermometer, 6- compensation bar

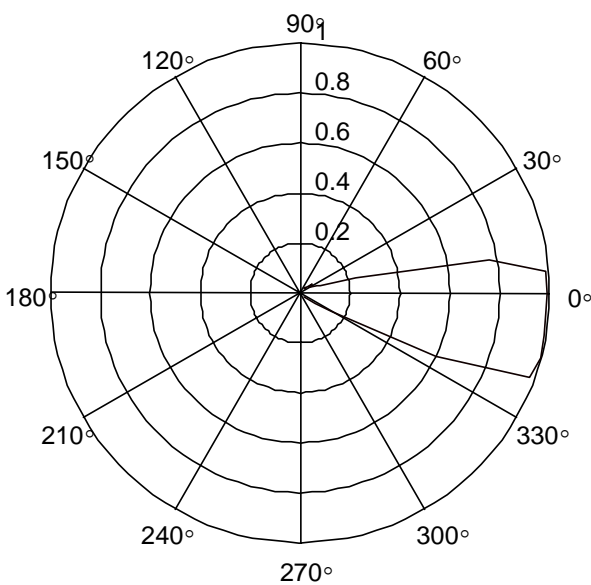

Fig.7. Axial directivity pattern

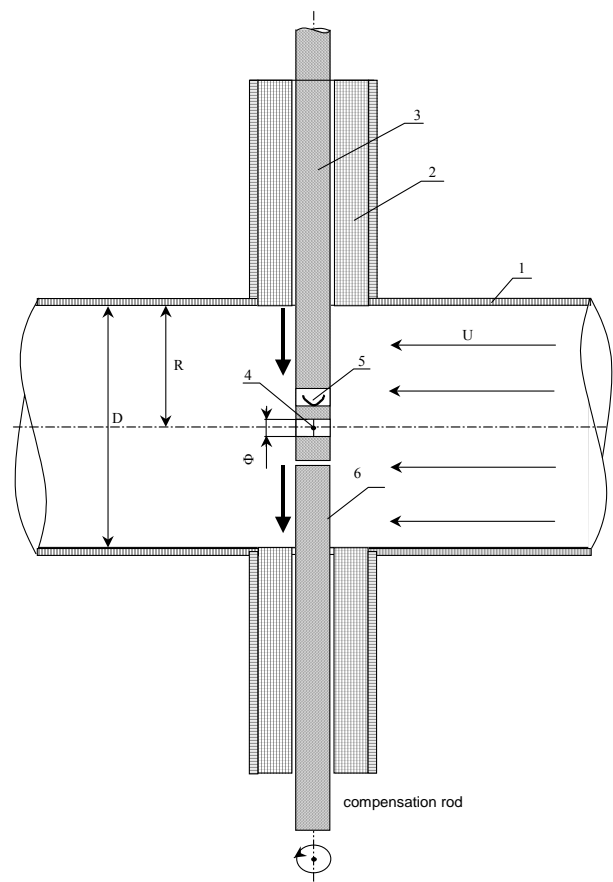

Fig.8. Measurement setup for local flow component

Flow profile measurements were performed inside the pipe, as shown in Fig.8. First of all scanning was performed without the compensation rod 6 (Fig.8), after that- with the compensation rod. Taking into account diameter of the anemometer's hole ($\varnothing=5$ mm), the scanning step was chosen 4 mm and at each point 12 measurements were performed. Without the compensation rod an asymmetric flow profile was obtained. In the case of the compensation rod symmetry of the measured flow profile is better, what corresponds to a physical reality. The biggest difference between flow velocities measured by two different methods is about 20% and it is obtained near

the wall of the pipe. Performing measurements deeper in the flow, curves 1 and 2 become closer to each other, what means that influence of the compensation rod become less effective. In both cases the flow velocity was the same ($v=2.04$ m/s).

Scattering of the measurement results, denoted in Fig.9 by a vertical line, may be caused by turbulence of the flow or it may be due to a random error of the meter. In the range of velocities (0.5-3.5) m/s random errors of the anemometer are $\pm 0.01 \pm 3\%$. At the flow velocity 2 m/s, the absolute random error does not exceed ± 0.07 m/s. Scattering of the flow velocity values in the vicinity of the walls is 0.2-0.3 m/s. At the centre of the pipe scattering is approximately two times less (Fig.9). Therefore it is possible to conclude that scattering of the measured flow velocities reflects flow velocity fluctuations caused by turbulence.

Also, from Fig.9 we can see that the results of measurements carried out without compensation rod are more scattered at the centre of the pipe ($l=35$ mm) than without the compensation rod. Closer to the wall scattering of the results in both cases is approximately the same. Therefore it is possible to conclude that the results obtained with the compensation rod are more accurate than the results published in [7].

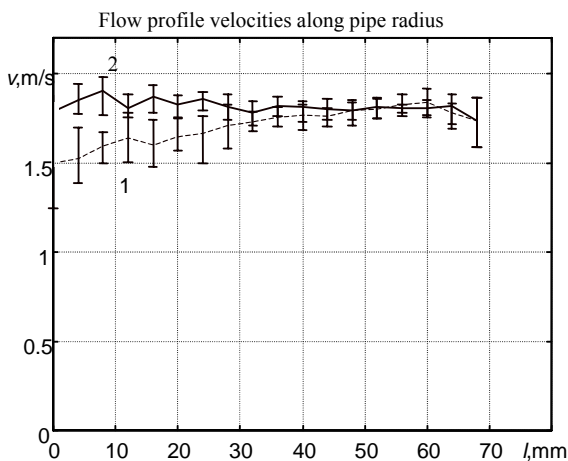

Fig. 9. Flow profiles: 1-without compensation rod, 2-with compensation rod

Similar measurements of the flow profile were performed with the vertically oriented anemometer's housing along the acoustic path, e.g. in 45° direction with respect to the pipe axis (Fig.10). In this case the measurement equipment is more complicated. In both walls of the pipe longitudinal slots wider than the diameter of the anemometer housing were machined. The anemometer 2 and the compensation bar 3 were fixed in the mounts 4,5, which were placed on the freely moving pipe sections. These sections cover hermetically the pipe 1 up to the middle of the pipe.

The moving sections can be shifted along the pipe 1 in the direction of pipe axis by the step 4 mm, and at the same time the vertically oriented anemometer is scanned across the diameter of the pipe by the step 4 mm also. In this way

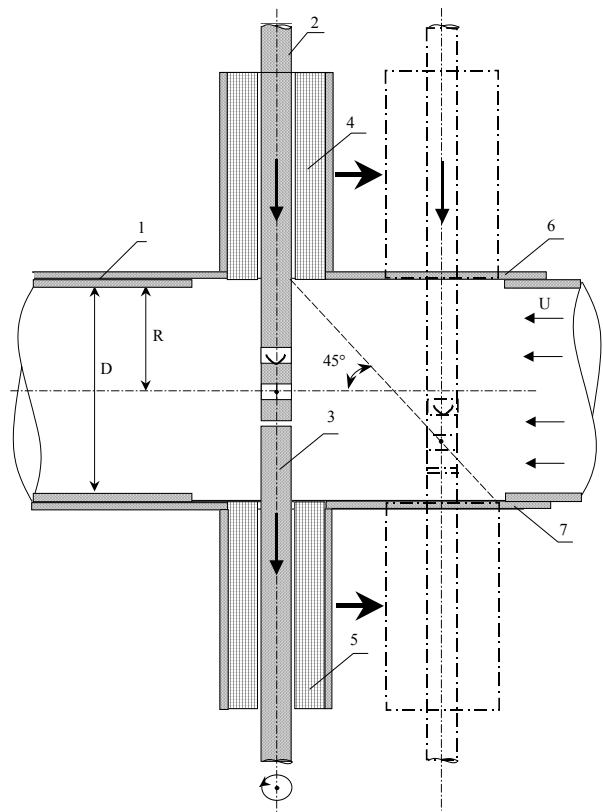

Fig.10. Equipment for local flow velocity measurement in the pipe

scanning angle 45° with respect to the flow direction is obtained. Please note, that in this case axis of the anemometer's hole with the flow-sensing element is oriented along pipe axis.

The measurement results are shown in Fig.11b. For comparison results obtained only across the pipe at the angle 90° (without scanning along the pipe) are presented in Fig.11a. In both cases the flow velocity measured with by the air velocity meter was 1.02 m/s. The results are presented in two different figures in order to display better scattering of the measurement results and measurement errors. The results presented indicate a rather unstable flow near the wall of the pipe and a stable turbulent flow in the middle (Fig.11a.). In the case of measurements along the acoustic path, scattering of the results is bigger than in the previous case (Fig.11b).

Investigation of the flow velocity profiles in the acoustic channel

Due to 3-dimensional character of gas flow profiles in pipes with recesses for ultrasonic transducers, experimental methods are most efficient for their investigation. The measurements should be performed along the acoustic path of the measurement section, which is inclined with respect to the pipe axis. These measurements may be carried out with different orientations of the anemometer to the flow. Therefore, the first objective of this investigation was to find out the optimal orientation of the anemometer in a flow. The second objective was to determine regularities and symmetry deviations of the flow profiles in the region of the acoustic path with recesses. The measurement circuit is shown in Fig.12.

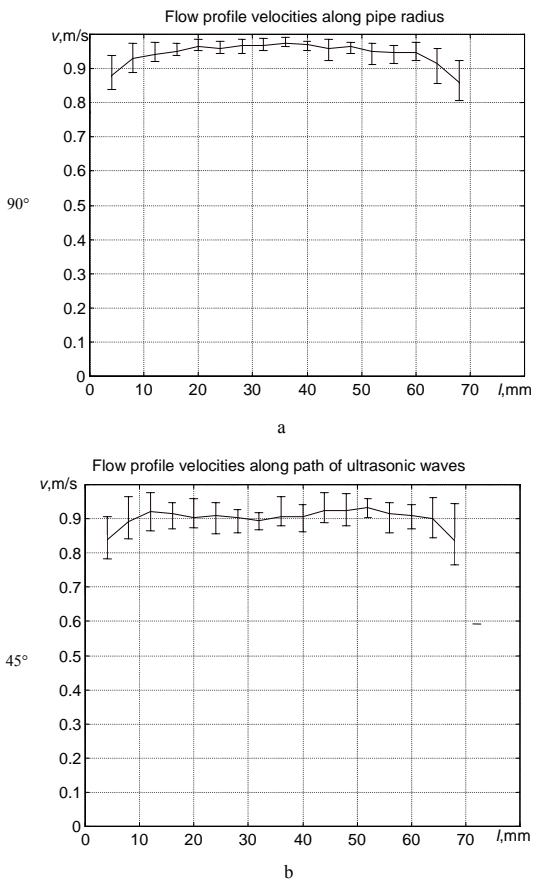

Fig.11. Flow profiles performing with vertically oriented thermoanemometer housing

The pipe 1 possesses the mounts 2, 3 which are filled with ultrasonic transducer mock-ups 4 and 5. These mock-ups are movable in the acoustical channel direction. Inside the transducer's mock-ups the anemometer 6 with heating element 7 and thermometer 8 is placed. The anemometer is inclined 45° degrees to the flow and it can be moved along the acoustical axis too.

Measurements of flow velocity profiles in the acoustical channel may be performed in two directions: upstream and downstream. Measurement results are presented in Fig.13.

From the results obtained follows that only upstream measurements are correct. The downstream measurements are correct only in a small area near the pipe wall. In the latter case the surface of the thermo anemometer's housing, directed windward, is causing gas stream formations, which are diverting the main flow from the hole of the flow sensing element. Therefore, the measured flow velocity values decreases when the anemometer is moving deeper. Contrarily, in the case of upstream measurements the sensing element is placed in the front part of the housing, which does not disturb the flow profile.

To verify this hypothesis additional investigations were performed using the additional bar, connected to the tip of the housing and similar to the compensation rod used in the 90° measurements. The measurements were performed in upstream direction (Fig.14.).

The additional bar connected to the tip of the thermo anemometer housing creates surface gas streams, which reduce the velocity of the flow, interacting with the flow-sensing element. Therefore, the flow velocities values obtained with the bar (Fig.14, curve 2) are smaller than without the bar. In the centre of the pipe the flow velocities

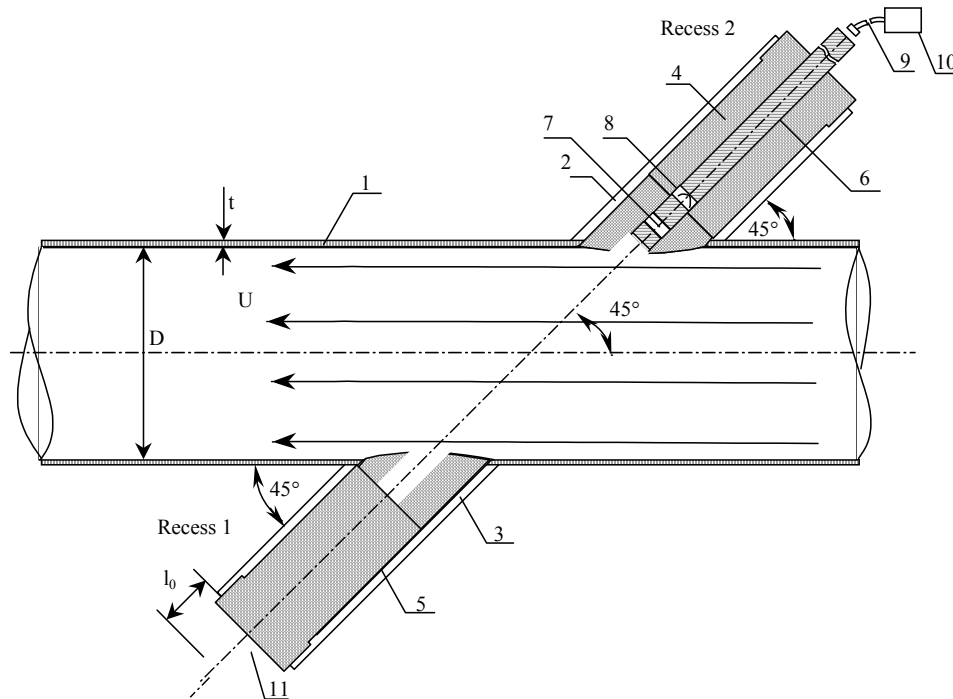

Fig.12. Arrangement for flow velocity measurements in a pipe

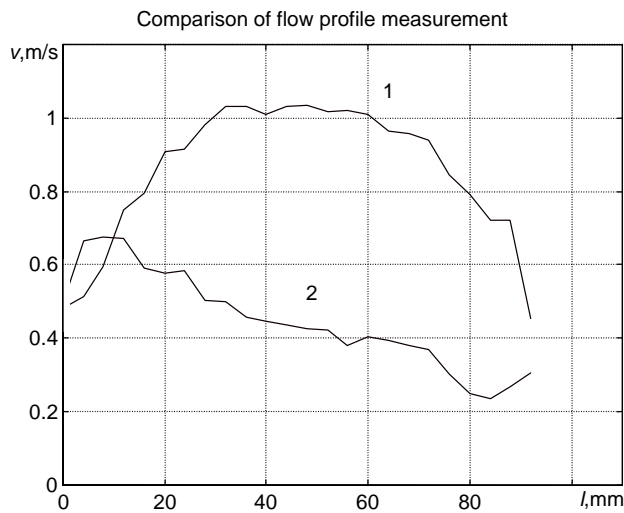

Fig.13. Flow velocity profile measured in the acoustical channel: 1-upstream, 2-downstream

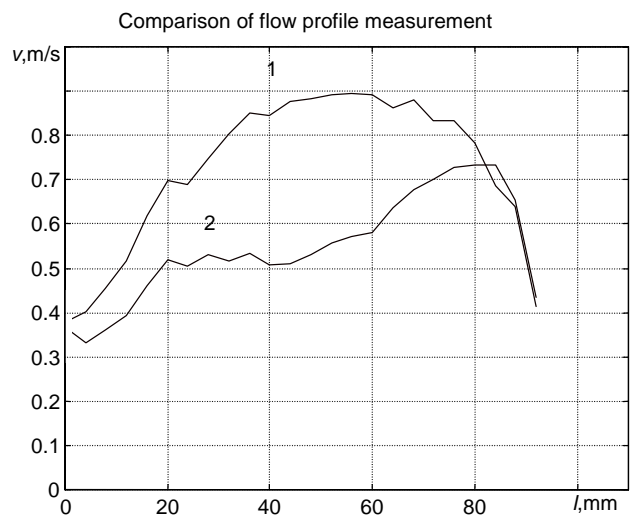

Fig.14. Flow profiles along path in the pipe, obtained by upstream measurements: 1- without additional bar, 2-with bar

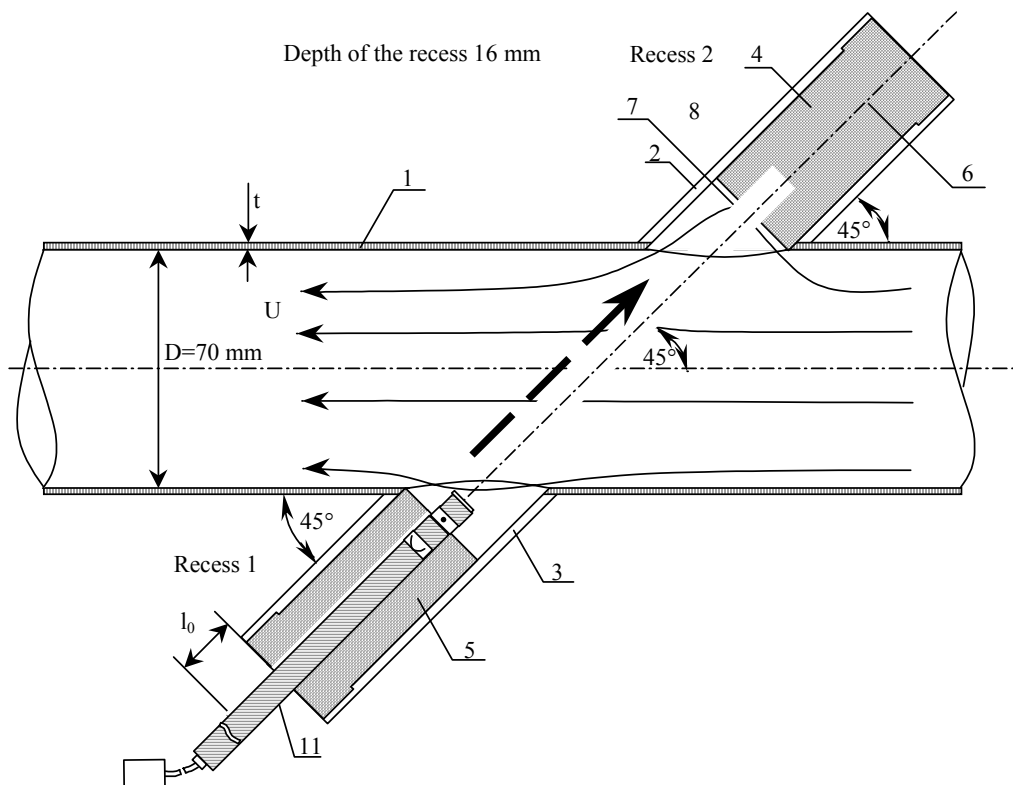

Fig.15. Flow velocity measurement in the acoustical channel

measured with the thermo anemometer and additional bar are (30-40)% lower than without the additional bar. The flow velocity measured with the air velocity meter at the centre of the pipe was 1.04 m/s. Further, e.g. near the opposite wall of the pipe, influence of the pipe disappears because the length of the additional bar inserted in the flow becomes minimal.

Distribution of flow velocities in the acoustical channel, e.g. inside the pipe and recesses of the transducers, was measured using experimental arrangement shown in Fig. 15, which is similar to the one presented in Fig.12, except that the recesses of the transducers are not filled. The initial position of the anemometer is such that the edge of the hole with the

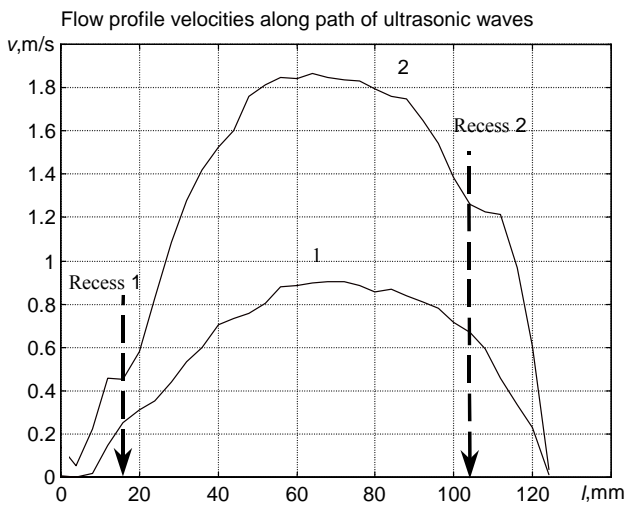

Fig.16. Flow profile in the acoustical channel:1-flow velocity 1 m/s, 2-flow velocity 2 m/s. By the dotted arrows the position of the tube inner surface is shown

sensing- element coincides with the surface of the transducers mock-ups. Scanning was performed by 4 mm steps. Measurements were performed at two different flow velocities. The results are shown in Fig.16. At the flow velocity 1 m/s, which is close to a transitional flow, the flow profile is asymmetrical with maximum shifted to the downstream recess. In the upstream recess the flow velocity is less than in the downstream recess. At the interfaces between recesses and the pipe the flow velocities seek 20 % from the maximal value for the upstream recess and 66 % for the downstream recess. In such a case a part of gas flow is diverted to the recess and as a result the average flow value becomes smaller.

Measurements with deeper recesses were performed too (Fig.17). The depth of both recesses was 10 mm. Like in the measurements performed with the shorter recesses (Fig.15, edge of the transducer mock-up coincides with the inner surface of the pipe) the flow velocity profiles are asymmetrical.

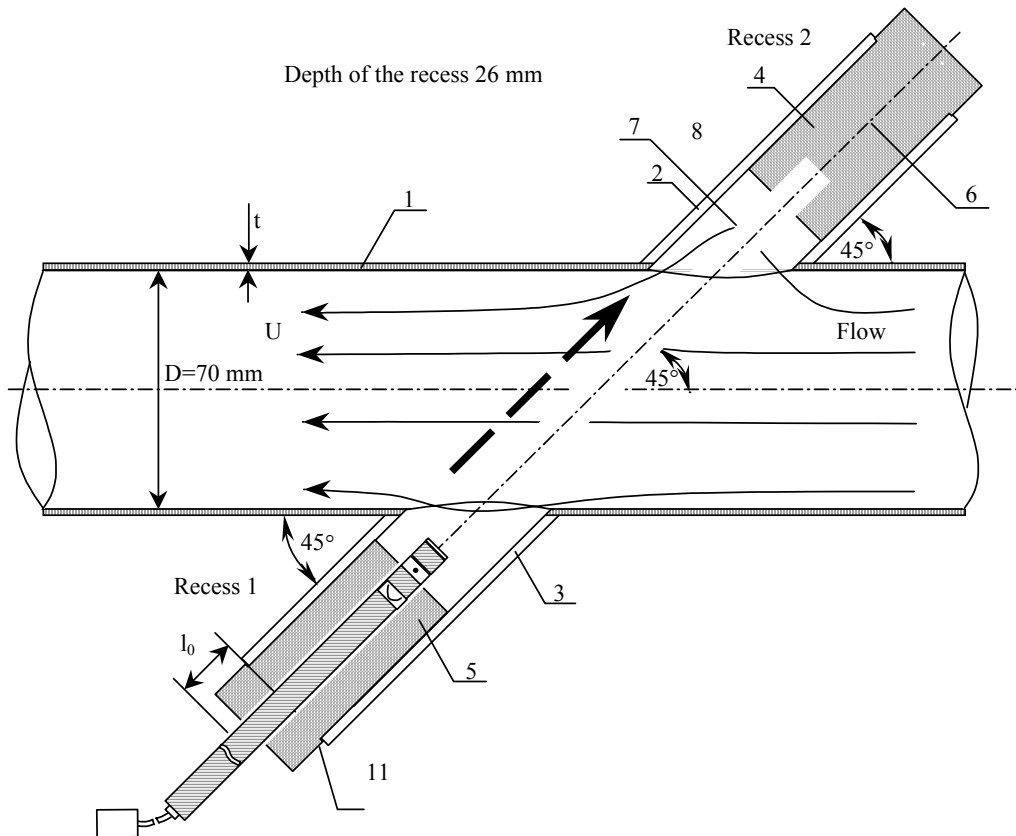

Fig.17. Arrangement for flow velocity measurements in the acoustical channel with deep recesses

Conclusions

1. In this paper measurement techniques and results of measurements of local flow velocity components using invasive flow sensors (anemometers) are described. Method for measurement of flow velocity profiles using invasive thermo anemometer oriented perpendicular or

across to the flow direction and it's calibration technique were developed. To reduce measurement errors obtained with the anemometer perpendicularly oriented in a flow, it was proposed to use the compensation rod with the same diameter as of the thermo anemometer. Obtained flow velocity distributions for cylindrical pipe are close to

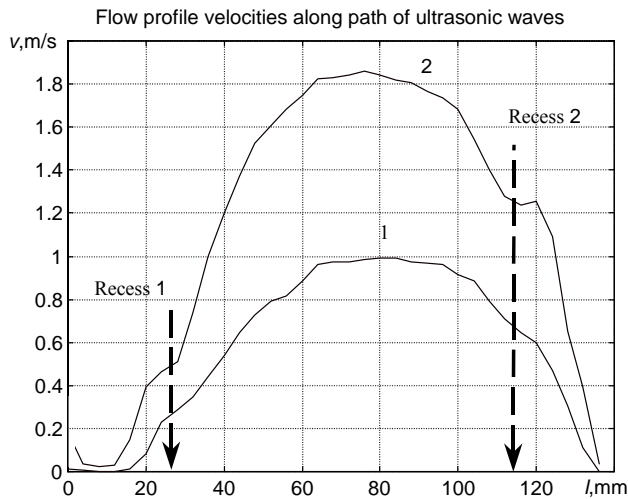

Fig.18. Flow profile in the acoustical channel with deep recesses: 1- flow velocity 1 m/s, 2-flow velocity 2 m/s

theoretical. The compensation rod reduces scattering of the measurement results.

2. Measurement methods of angular and axial directivity patterns of anemometer in the gas flow were developed. Those measurements showed that anemometer d2.60 can be used for flow velocity measurements in the sector $\pm 30^\circ$ with respect to the direction of the flow.

3. It was determined that in the region where ultrasonic waves propagate the flow profile is asymmetric due to recesses in which ultrasonic transducers are mounted. The flow profile is inclined to the direction of the downstream recess and depends of the recesses depth.

4. High accuracy and resolution of the anemometer's errors enable estimate flow fluctuations, which are bigger at the walls of a pipe and smaller in the centre.

5. Measurements of the flow velocities in the acoustical channel, performed upstream are more accurate than downstream. The compensation rod in this case gives no advantages.

Reference

1. **Lynnworth L. C.** Ultrasonic flow meters. /Physical acoustic. New York: Academic press. 1979. P.480-520.
2. **Хальдунин В. К.** Ультразвуковые контрольно – измерительные устройства и системы. Ленинград: Ленинградский университет. 1989. 220 с.
3. **Spitzer D. W.** Flow measurement: Practical guides for measurement and control./ Instrument society of Amer. USA, 1993. P.611.
4. **Mylvaganam K.S.** Ultraschall - Durchfluß - messung strömender Gase unter niedrigem Druck für einen breiten Meßbereich./Technisches Messen, 1986, Hef t3, S.112-115.
5. **Lynnworth L. C.** Ultrasonic gas flow meters./Measurement and control, 1995, P.92-101.
6. **Köchner H., Melling A., Baumgärtner M.** Optical flow fields investigations for design improvements of an ultrasonic gas meter. /Flow Meas. Instrum. 1996. Vol 7, No 314, P.133-140.
7. **Cassetta F., Vigo P.** Sensors for measuring flow. In sensors: a comprehensive survey. Vol.7. VCH. Weinheim, 1994. P.375-436.

R. Kažys, A. Vladišauskas, R. Raišutis

Dujų srautų profilių tyrimas ultragarsiniuose srauto matuokliuose

Reziumė

Straipsnyje nagrinėjamos lokalinio srauto greičio matavimo invaziniais matuokliais (termoanemometrais) galimybės ir rezultatai. Sukurta metodika lokalinio srauto greičiui matuoti, panaudojant statmenai arba kampiu orientuotą termoanemometrą. Matavimo paklaidoms sumažinti statmenos orientacijos atveju, naudojamas termoanemometro korpuso skersmenį atitinkantis kompensacinis strypas. Cilindriniam vamzdyje išmatuoti srauto greičio pasiskirstymai artimi teoriniams. Naudojant kompensacinį strypą sumažėja matavimo rezultatų sklaida.

Sukurtos metodikos termoanemometro kampinei ir ašinei kryptingumo diagramoms matuoti dujų sraute.

Matavimo rezultatai parodė, kad dujų srauto profilis akustiniame kanale yra nesimetrinis.

Profilio kreivė, palinkusi į srauto kryptimi orientuotą pjezokeitklio nišą ir priklauso nuo jos gylio. Srauto fliktuacijų reikšmės didesnės yra vamzdžio pakraščiuose ir mažesnės jo viduryje. Srauto greičiai akustiniame kanale tiksliau išmatuojami prieš srautą orientuotu termoanemometru.

Pateikta spaudai 2001 10 21

DOI: 10.5755/j01.u.40.3.8075