

## Investigation of ultrasonic system for measurement of slow gas flow velocity

J. Butkus, L. Jakevičius,

Prof. K.Baršauskas Ultrasound Institute

Kaunas University of Technology

### Introduction

In modern technology it is very important to measure velocity of movement of natural gas, air, oil products and other chemical materials and to ensure high accuracy of measurements [1,2]. One of the most actual problems, when measuring flow velocity, is the slow gas flow velocity measurement ( $v < 0.1 \dots 0.2 \text{ m/s}$ ) [3]. It is due to wide use of such gas flows when creating the systems of maintenance of microclimate, ventilation and air heating [4].

Technology of measurements was rapidly developing in last years, and new standards for gas flow velocity measurement were proposed [5]. That enables one to increase accuracy of gas flow velocity measurements and to ensure reliability of the measuring results [5,6]. Besides this, the beginning of Internet enabled to compare the measurement results of flow velocity and other parameters, which were obtained in different laboratories [6-10]. Ultrasound multichannel meters and measuring systems, which were used like secondary standards of gas flow velocity and flow rate measurements have especially good perspectives in this field [11]. For example, when increasing the number of ultrasonic measuring channels from 8 to 11, the expanded uncertainty of the gas flow velocity measurement may be decreased to the value  $\pm 0.2\%$  [11]. It indicates the perspectiveness of multichannel ultrasonic measuring methods, their using possibilities and their ability to respond to up-to-date demands. But the possibilities of ultrasonic methods in the field of slow gas flows are investigated insufficiently [8-11]. Besides that, when measuring slow rate gas flow velocity, one of the most actual problems remains the zero drift of ultrasonic meters [12-14]. Therefore, the aim of this investigation was to minimize the influence of zero drift of the ultrasonic measuring system when measuring low gas flow velocity.

### Measurement equipment, results and discussion

When stability of an ultrasonic measuring system was investigated in laboratory conditions it appeared that the main factor influencing zero drift of the measuring system is thermal instability of ultrasonic measuring channel and electronic equipment [13,14]. For better investigation of zero drift of the system, when the temperature and the other parameters of environment are changing, the measuring spoolpiece (which was mounted at the Lithuanian Energy institute) was replaced by the new one. The new measuring section consists of the metal pipe and ultrasonic transducers mounted at the ends of it (Fig.1). The diameter of the spoolpiece  $d=0.11 \text{ m}$ . The distance

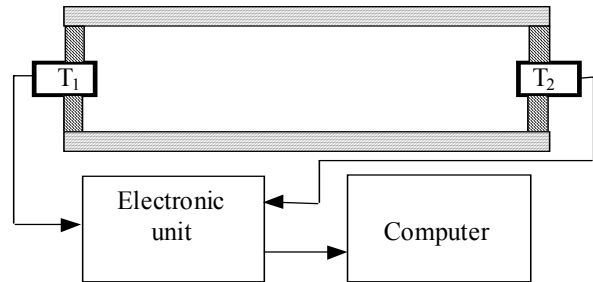

Fig.1. Model of ultrasonic measuring system for zero drift investigation

between ultrasonic transducers was left the same as the one at the Energy Institute  $l=0.59215 \text{ m}$  [14]. In such a way, the volume of the measuring section was decreased extremely when compared with that of the Energy Institute, where the diameter of spoolpiece was  $0.4 \text{ m}$ . The motion of air in the measuring area caused by its natural convection and its influence on the zero drift of ultrasonic system decreased too. Our investigations showed that the fluctuations of the zero drift of ultrasonic measuring system in the round clock period were often similar [13,14]. Besides that, there were the cases when zero drift of the ultrasonic system changed extremely differently in different days (Fig.2). When comparing the fluctuations of zero drift of the ultrasonic system obtained in different days at the same ultrasound velocity (temperature) one can notice the similarity of their alteration. It is evidently seen from Fig.3, where the zero drift of the ultrasonic system for a gas flow velocity measurement is shown. The presented results were obtained when the temperature (sound velocity in hermetically closed measuring spoolpiece) changed at a few day periods. Like one can see from Fig.3, the dependence of zero drift of ultrasonic system on the measured sound velocity (temperature) in the measuring section is very complicated. Therefore the influence of the spoolpiece temperature change on the zero drift of ultrasonic system was investigated.

For this purpose the whole length of the measuring section was uniformly covered with the heating elements (Fig.4). The temperature of these elements was measured by the platinum resistor thermometer Pt-500. In order to decrease the influence of the ambient temperature the measuring spoolpiece was covered with mineral cotton. The thickness of covering was  $30 \text{ mm}$ . The temperature of the measuring electronic unit was stabilized by the 1-st thermostatizer and the temperature of the measuring section by the 2-nd one. The temperature of the measuring electronic unit was stabilized at the level of  $30^0 \pm 0.05 \text{ C}$  or

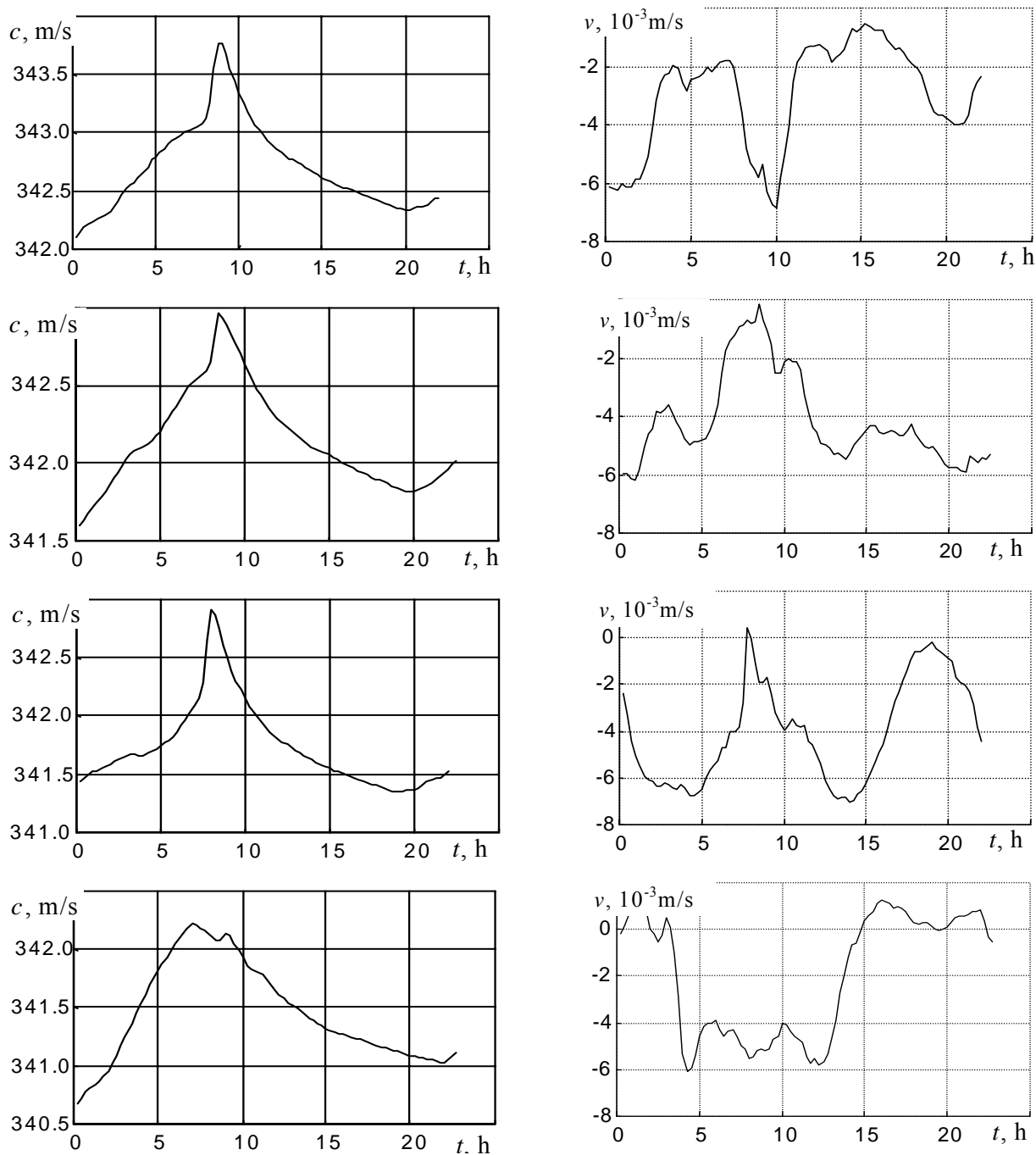

Fig.2. Variations of ultrasound velocity and zero drift of ultrasonic system at different days

uniformly changed in the range of  $30^{\circ}\dots 40^{\circ}\text{C}$ . The temperature of the measuring spoolpiece was maintained constant with the accuracy  $\pm 0.05^{\circ}\text{C}$  in all  $n=11$  discrete points of its alteration range. Number  $n$  is a freely chosen discrete temperature level between  $20^{\circ}\text{C}$  and  $30^{\circ}\text{C}$ . At the end points of this range the temperature was measured additionally by the mercury thermometers OMEGA ASTM-44C and ASTM-118C. The ASTM-116C thermometer measured the temperature in the middle of this region too. The scale value of all thermometers mentioned above was  $0.05^{\circ}\text{C}$ .

When keeping the temperature of the measuring spoolpiece constant with the accuracy of  $\pm 0.05^{\circ}\text{C}$  it was

noticed that the zero drift of ultrasonic measuring system frequently fit in  $\pm 1\text{mm/s}$  (Fig5) within the 24 hour period. However when repeating the tests a few days one after another and changing discretely the spoolpiece temperature by  $1^{\circ}\text{C}$  it was noticed that the change of zero drift in some experiments were quite different. Then the temperature of the measuring section was increased discretely by  $1^{\circ}\text{C}$  per day ten days in a row and after that decreased by analogy (Fig.6). How one can see from Fig.6, when discretely raising or lowering the temperature of the measuring section, the zero drift of ultrasonic system changed mainly only when there were the jumps of temperature. It showed that the zero drift of the ultrasonic measuring system is

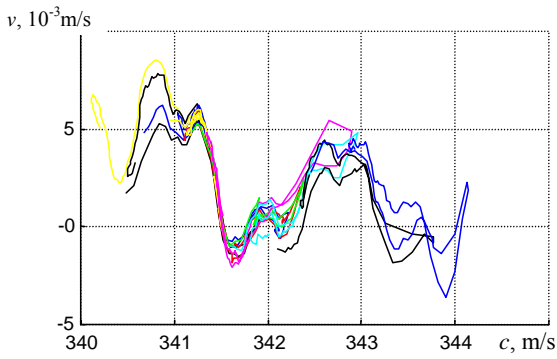

Fig.3. The change of zero drift when the temperature in the laboratory (sound velocity) was changing in 10 days period

mostly dependent on the possible gradients of temperature in the measuring channel. However when the temperature of the measuring section was stable enough (the magnitude of the sound velocity fluctuations was only 3cm/s per day, what corresponds to the temperature fluctuation only of 0.05°C) the magnitude of the zero drift was about 0.5-3.5mm/s (Fig.7) in some cases. Such a big zero drift, when the temperature changes of the measuring spoolpiece were insignificant, force us to look for the reason of such slow variations of the zero drift of the system.

With the purpose to minimize the influence of the possible temperature gradients, the temperature of the spoolpiece was raised very slowly by 0.01°C per minute. In

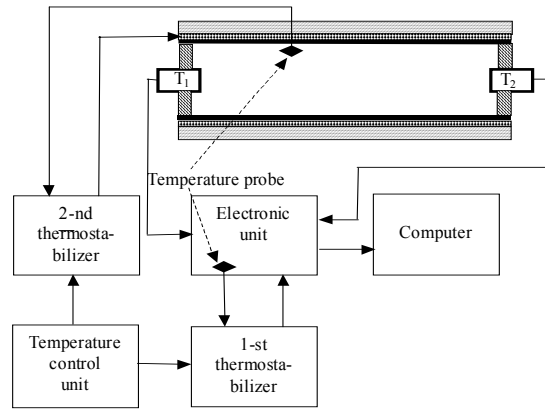

Fig.4. Block diagram of the system for temperature control and stabilisation

order to change the temperature of the measuring section as uniformly as possible the digital unit for control of the spoolpiece temperature was developed. By using this unit the temperature of the measuring channel may be increased or decreased uniformly in the whole temperature range mentioned above. Except that, the whole 10°C temperature region may be discretely shifted from 20°C to 30°C step by step. This enables to extend the boundaries of investigation of the ultrasonic measuring system in a wider temperature range.

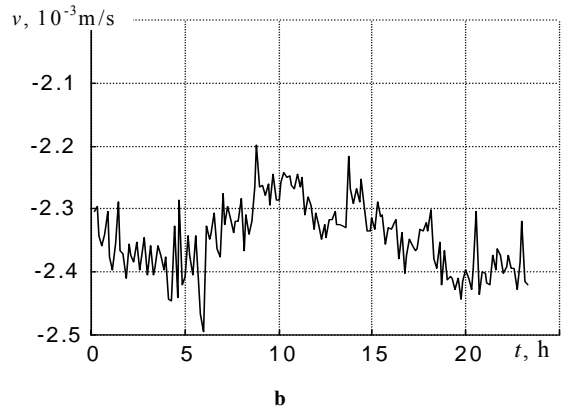
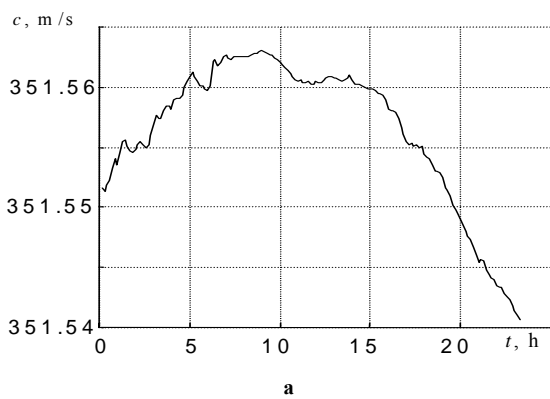

Fig.5. The fluctuations of sound velocity (a) and zero drift of ultrasonic system (b) within the 24 hour period

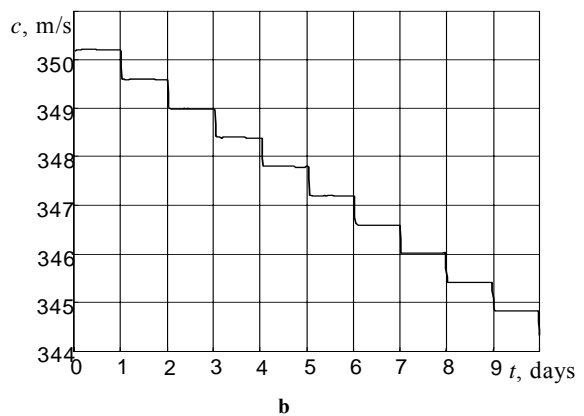
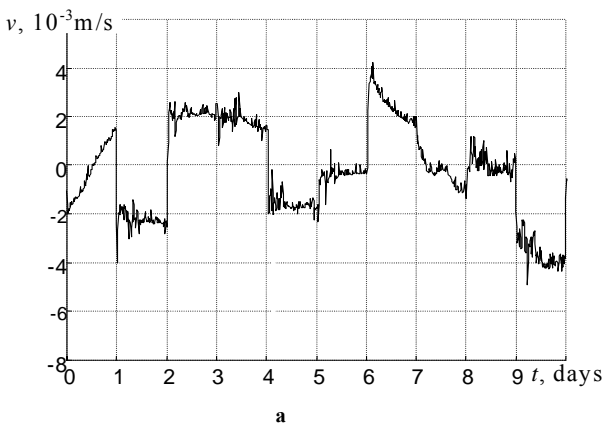

Fig.6. The variations of zero drift-a) and sound velocity-b) in 10 days period, when the temperature of the spoolpiece was decreased step by step

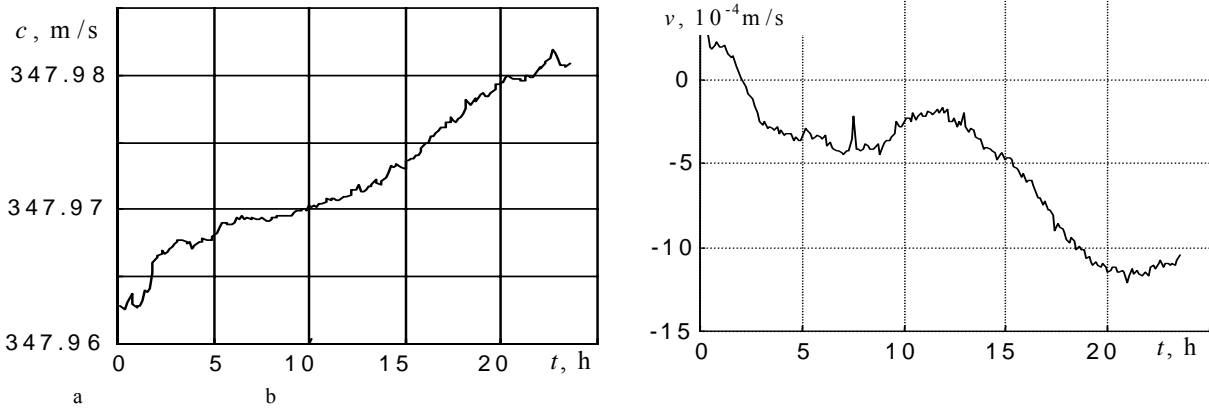

Fig.7. The change of sound velocity-a) and zero drift of the system-b) when the temperature of the spoolpiece was stabilized

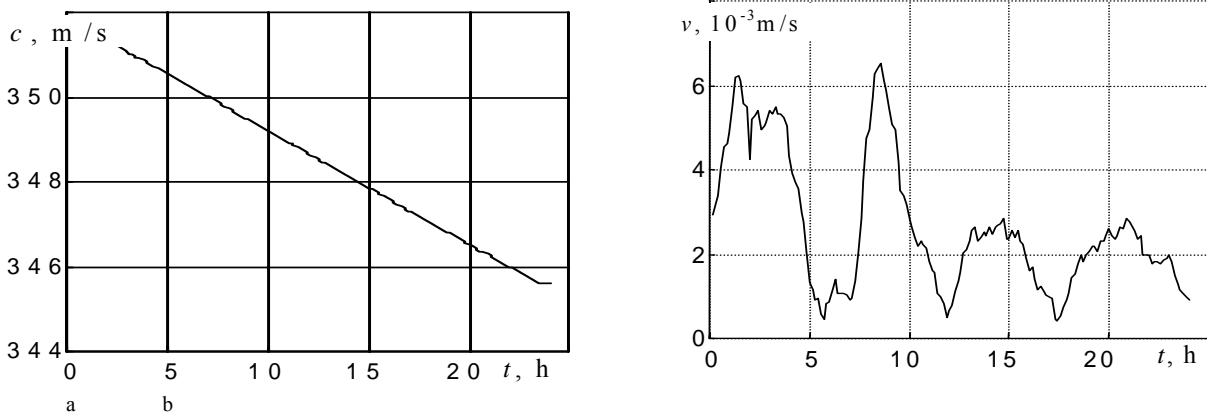

Fig.8. The alteration of sound velocity-a) and zero drift-b) when the temperature of measuring channel was slowly decreased

When raising and lowering the temperature of the measuring spoolpiece, the change of the sound velocity in the air filling the measuring section reflected the changes of temperature extremely well. So in all experiments the sound velocity in air filling the spoolpiece was registered instead of temperature. The results of measurements are shown in Fig.8. With the purpose to eliminate the influence of temperature on the zero drift of the system, the alteration of zero drift depending on the sound velocity (temperature) in the spoolpiece was measured. When repeating the experiments several times, it was noticed that the change of the zero drift of the ultrasonic system was

very similar when the temperature of the measuring section was changed slowly. After the averaging of the test results of the few days it was obtained a reference dependence curve of the zero drift of ultrasonic system on the sound velocity (temperature) in air inside the measuring section (Fig.9). Then appeared the possibility to eliminate the influence of spoolpiece temperature on the zero drift of ultrasonic system. For that purpose the reference values of zero drift obtained at the same sound velocity (temperature) (Fig.9) may be subtracted from the values of zero drift obtained by the measuring process (Fig.10). Thus the zero drift of ultrasonic system may be decreased to the level  $\pm 1 \dots 1.5 \text{ mm/s}$  (Fig.11) when the temperature of the spoolpiece is being changed in the range between  $23^{\circ}\text{C}$  and  $33^{\circ}\text{C}$ . In a similar manner the zero drift of the ultrasonic system for gas flow velocity measurement may be eliminated in a different temperature range.

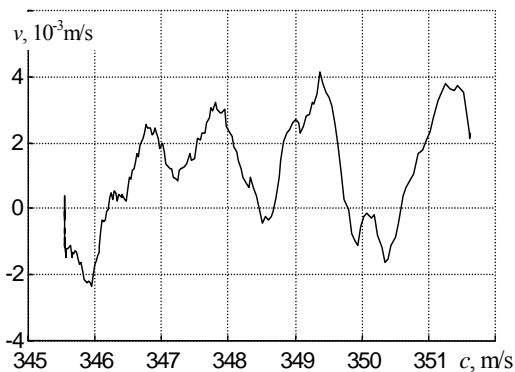

Fig.9. The reference curve of dependence of the zero drift of the ultrasonic system on the sound velocity in the measuring channel

### Conclusions

From the obtained results it can be concluded that the main factor determining the zero drift of an ultrasonic system for gas flow velocity measurement is the instability of temperature in the measuring spoolpiece. It appeared that the zero drift of the ultrasonic system is strongly dependent on the possible gradients of temperature in the measuring channel. Therefore when measuring the gas flow velocity it is necessary to evaluate and to minimize the influence of these factors. The method for

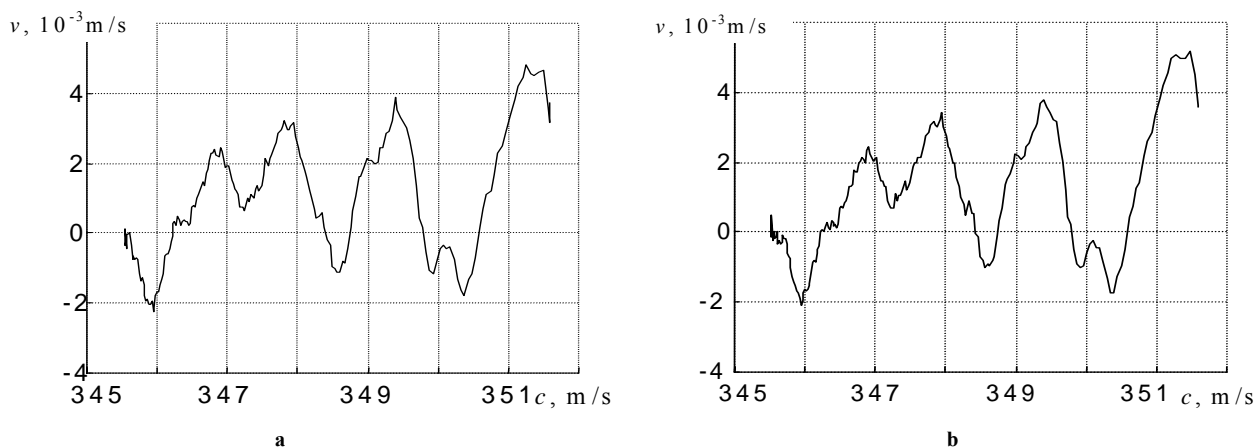

Fig.10. The change of zero drift of the ultrasonic system in two days period when the sound velocity (temperature) in the spoolpiece is changed

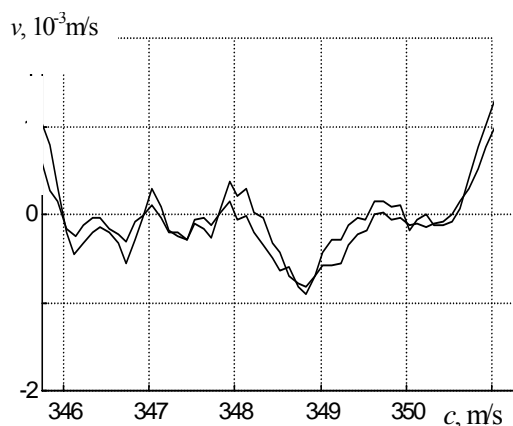

Fig.11. The alteration of zero drift of ultrasonic system after the evaluation of influence of temperature change in measuring channel

minimization of zero flow instability is proposed. This enables one to diminish the zero drift of the ultrasonic system for gas flow velocity measurements to the level of  $\pm 1 \dots 1.5 \text{ mm/s}$ .

### Acknowledgment

This project is sponsored by the Lithuanian State Science and Studies Foundation.

### References

1. **Lynnworth L.C.** Ultrasonic Flowmeters Physical Acoustics. New York: Academic Press. 1979. P.408-520.
2. **Mylvaganam K.S.** High-rangeability ultrasonic gas flowmeter for monitoring flare gas. IEEE Transaction of ultrasonic, ferroelectrics and frequency control. 1989.Vol.36. No.2. P.144-149.
3. **Grant I., Mo M., Pan X., Parkin P., Powell J., Hurst D.** Computerised animation of PIV measurements and laser sheet visualisation in the wake of a passenger aircraft model in a large, low speed wind tunnel. Proc 8th Int. Symp. on Flow Visualisation, Sorrento, September 1-4, 1998. Paper 277. P. 277.1-277.8.
4. **Reynolds D.D., Bride W.T., Clark B., Giles B., Nolfo A. and others.** Sound and vibration. Design and analysis. National Environmental Balancing Bureau. Rockville. 1994. 193 p.
5. **Bean V. E., and Hall J. M.** New primary standards for air speed measurement at NIST. Proceedings of the 1999 NCSL Workshop and Symposium (Charlotte, NC: NCSL 1999). P.413-421.

6. **Bean V. E., Hall J. M. and Mattingly G. E.** Preliminary results from interlaboratory comparison of air speed measurements between 0.3 m/s and 15 m/s. Proceedings of the 1999 NCSL Workshop and Symposium (Charlotte, NC: NCSL 1999). P. 423-434.
7. **Wright J. D., Ward D. B. and Mattingly G. E.** Validating uncertainty analyses for Gas flow standards via intra- and Inter-laboratory comparisons. Proceedings of the 1999 NCSL Workshop and Symposium (Charlotte, NC: NCSL 1999). P. 711-724.
8. **Espina P. I., Yeh T. T., Rothfleisch P. I. and Osella S. A.** Tele-metrology and advanced ultrasonic flow metering (updated version). Proceedings of the International conference on metrology (Jerusalem, Israel: INPL 2000). P. 137-147.
9. **Espina P. I.** Flow tele-metrology. Proceedings of the IEEE Instrumentation and measurement Technology Conference (Venice, Italy: IMTC 1999). P.23-33.
10. **Espina P. I.** Tele-calibration of gas flow meters. Proceedings of the 1999 Measurement Science Conference (Anaheim, CA: MSC 1999). 6 p.
11. **Mattingly G. E. and Yeh T. T.** NIST's ultrasonic technology assessment program to improve flow measurements. NIST TN-1429. 2000.
12. **Hakanson E., Delsing J.** Effects of flow disturbance on an ultrasonic gas flowmeter. Flow Meas. Instrum. Vol.3. No.4. 1992. P. 227-233.
13. **Butkus J., Jakevičius L.** Peculiarities of slow rate gas flow velocity measurement. Ultragarsas. Nr. 4(37). 2000. P.24-28.
14. **Butkus J., Jakevičius L.** Ultragarsinės dujų srautų greičio matavimo sistemos stabilumo tyrimas. Ultragarsas. Nr.3(40). 2001. P. 36-39.

J. Butkus, L. Jakevičius

### Mažo greičio dujų srautų ultragarsinės matavimo sistemos tyrimas

#### Reziumė

Parodoma, kad mažiems dujų srautų greičiams ( $v \leq 0,2-0,3 \text{ m/s}$ ) matuoti, vienos perspektyviausių yra daugiakanalės ultragarsinės matavimo sistemos. Eksperimentiškai nustatyta, kad ypač svarbus veiksnys, ribojantis matavimo tikslumą mažų greičių ruože, yra sistemos nulio dreifas. Nustatyta, kad daugiausia įtakos nulio dreifo kitimui turi matavimų ruožo temperatūros nestabilumas ir galimi temperatūros gradientai matavimo kanale. Nulio dreifo įtakai sumažinti pradžioje siūloma iširti jo temperatūrinę priklausomybę visame matavimų sekcijos galimų temperatūrų ruože. Temperatūrai nustatyti siūloma pasinaudoti matavimo metu gautomis garso greičio tiriamose dujose vertėmis. Matuojant dujų srauto greitį, iš matavimo metu gautų verčių, siūloma atimti nulio dreifo vertes, esant atitinkamam garso greičiui. Taip koreguojant matavimo rezultatus, ultragarsinės matavimo sistemos nulio dreifo įtaka srauto greičio matavimo rezultatams gali būti sumažinama iki 1-2 mm/s lygio.

Pateikta spaudai 2002 03 12

DOI: 10.5755/j01.u.42.1.8110