

Experimental investigation of gas flow in pipes with recesses for ultrasonic transducers

R. Kažys, A. Vladišauskas, R. Raišutis

Prof. K.Baršauskas ultrasound institute

Kaunas University of Technology

Introduction

Accuracy of flowrate measurements in pipes by ultrasonic flowmeters is strongly affected by a profile of flow velocity vector. Investigations of flow gas profiles in pipes are reported in many works [1-5]. These investigations usually were carried out in measuring tubes without recesses for mounting of ultrasonic transducers. A flow velocity profile is limited by an internal wall of the pipes. Actually a gas flow is distributed in all space inside a pipe including the recesses of transducers. That influences a flow velocity profile in an acoustical channel where ultrasound beam propagates. The dependence of the flow measurement accuracy on velocity profiles encountered by an ultrasound beam propagating along the measuring path is an important design parameter. Measurements of a flow velocity along all measuring path of the special construction were carried out by us [6].

The aim of this research was experimental investigation of air velocities profiles in the recesses of ultrasonic transducers along the propagation with of ultrasonic waves. For this purpose miniature invasive flow sensors such as a thermoanemometer and some additional set up were used. A flow velocity vector in the recesses of transducers usually does not coincide with the axis of the thermoanemometer hole, therefore measurements of the directivity patterns thermoanemometer was performed too [7].

Determination of the recesses depth

Size and geometry of recess are defined by a few construction parameters:

- position of the transducers in the recesses;
- an angle between a centreline of the pipe and an acoustical axis of the transducer;
- a diameter of the transducer and a size of the gap between the transducer and the housing walls.

If an edge of the front surface transducer coincides with a surface of the pipe wall (Fig.1), a depth of the recess l_n can be found:

$$l_n = \frac{D_n}{2 \tan \theta}, \quad (1)$$

where D_n is the diameter of the recess, θ is the angle between centreline of the pipe and the acoustical axis of the transducer.

The diameter of the recess depends on the diameter of a transducer and the gap. If both transducers are situated in the recesses of the transducers T_1 and T_2 (Fig.1), we have the symmetrical case and the depth of the recesses is equal.

When one of the transducer is deeper in the recess, it corresponds to the asymmetrical case. Then the depth (according to acoustical axis of the transducer) will be

$$l = 2l_n + l_0 \quad (2)$$

where l_0 is the distance between the front surface of transducer and the internal wall of a pipe.

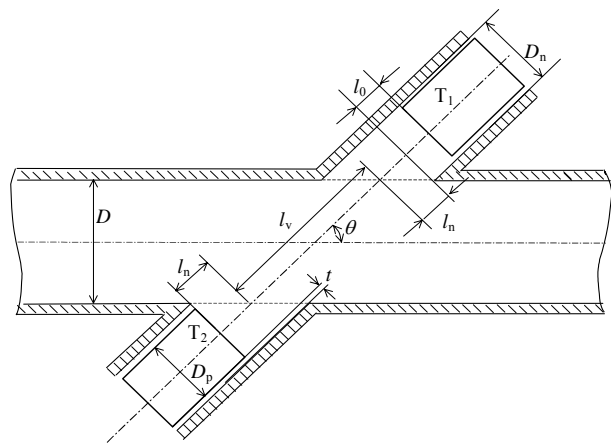

Fig. 1. Measurement path of flow

The diameter of the recess

$$D_n = D_p + 2t \quad (3)$$

where D_p is the diameter of the transducer, t is the size of the gap.

The depth of one recess for the symmetrical case is given by

$$l_n = \frac{D_p + 2t}{2 \tan \theta} \quad (4)$$

and for the asymmetrical case

$$l_n = \frac{D_p + 2t}{2 \tan \theta} + l_0. \quad (5)$$

In this way the depth of the transducer recess depends on the angle θ and the diameter of the recess. Calculations for different angles and for the diameter of a transducer 12mm was performed (Fig.2). The data obtained show that the depth of recesses strongly depends on the angle in the range $\theta=20^\circ-40^\circ$ and less depends on the diameter of the transducer. The larger angles give smaller depth of the recess, but they are not suitable for ensuring high accuracy of ultrasonic flow meters.

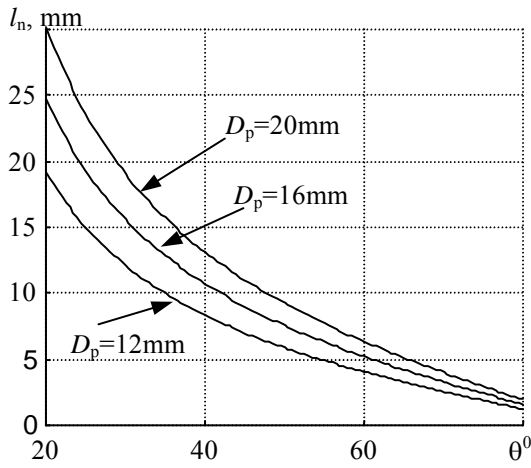

Fig.2. Dependence of the depth of recesses upon angle

Experimental investigations

For flow velocity measurements in the recesses of transducers a special set up was used. It was necessary to provide a hermetically sealed pipe space, to move the thermoanemometer in the recess and to change the depth of a recess. Also the recesses with metallic grid and without it were investigated. The measurement set up of the flow velocity in the recess with a metallic grid is shown in Fig.3. It consists of the pipe 1, mount of transducer 2,

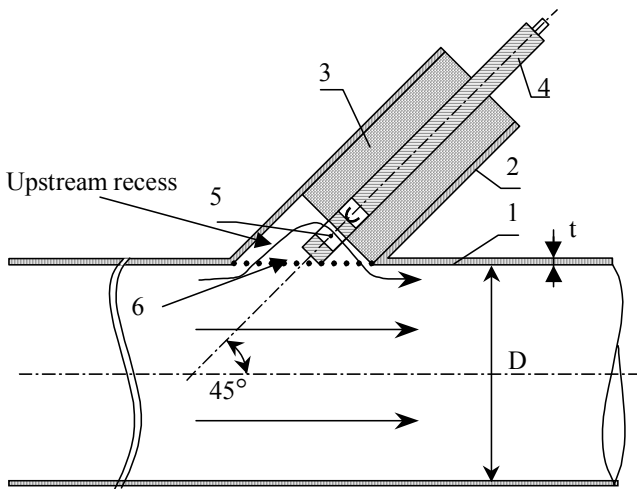

Fig. 3. Experimental set up for measurement of a flow velocity in a recess with a metallic grid

transducer mock up 3, housing of the thermoanemometer 4, flow-sensing element 5, and metallic grid 6. A hole of the sensing element is located over a surface of the transducer. The results of the flow velocity measurements in the recess are shown in Fig.4. From the results obtained in this picture follows that the flow velocity up to 1 m/s in the pipe does not create the flow in the recess near the surface of transducer. If the grid is used-such a condition holds up to 2 m/s. At higher flow velocities in the pipe difference between flows in the recess with grid and without grid appears. This difference is approximately 0,2 m/s in the range from 3 m/s to 10 m/s. In measurements a metallic grid, which had the thickness of wires 0,2 mm and

a distance between wire 1 mm was used. Transfer losses of the ultrasonic signal were -3 dB at the frequency 0,5 MHz. Decrease of the flow velocity in the recess can be achieved by increasing a density of the grid, however the transfer losses of the ultrasonic signal will increase.

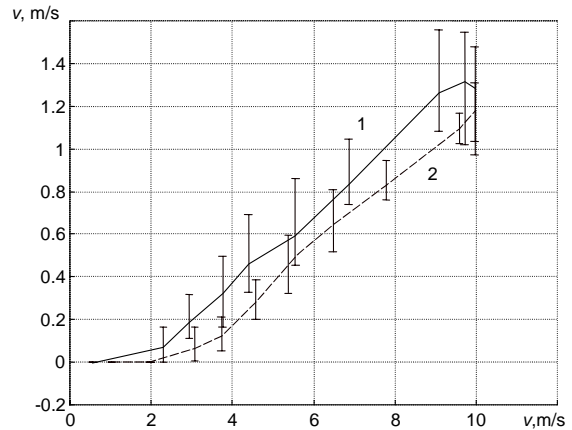

Fig. 4. Flow velocity in the upstream recess near by the surface of a transducer: 1-without grid, 2-with grid

From Fig.4 should be noted that the grid causes smaller flow velocity fluctuations in the recess (vertical bars from 12 measurements at each point).

The recesses of transducers are situated asymmetrically with respect to the flow velocity in a pipe. Therefore it is interesting to measure a flow velocity in the downstream and upstream recesses. Measurements were carried out using the set up shown in Fig.3 without a grid and the results are presented in Fig.5.

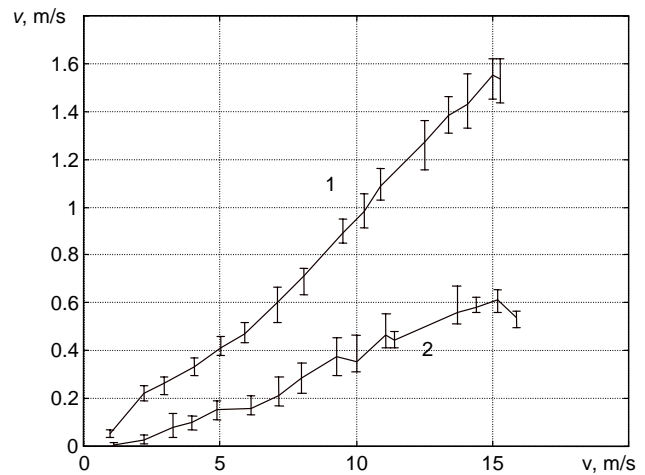

Fig. 5. Flow velocity in the upstream and downstream recesses: 1- upstream recess; 2- downstream recess

From the results obtained follows that difference of the flow velocity in the upstream and downstream recesses depends on the flow velocity in the pipe. The flow velocity in the upstream recess two times bigger than the flow velocity in the downstream recess. The flow velocity value in the upstream recess (near the surface of the transducer) is up to 10% from the maximal flow velocity in the pipe.

More detailed investigation of a flow velocity in the recesses of transducers was performed using a few different mock-ups, as it is shown in Fig.6a and Fig.6b.

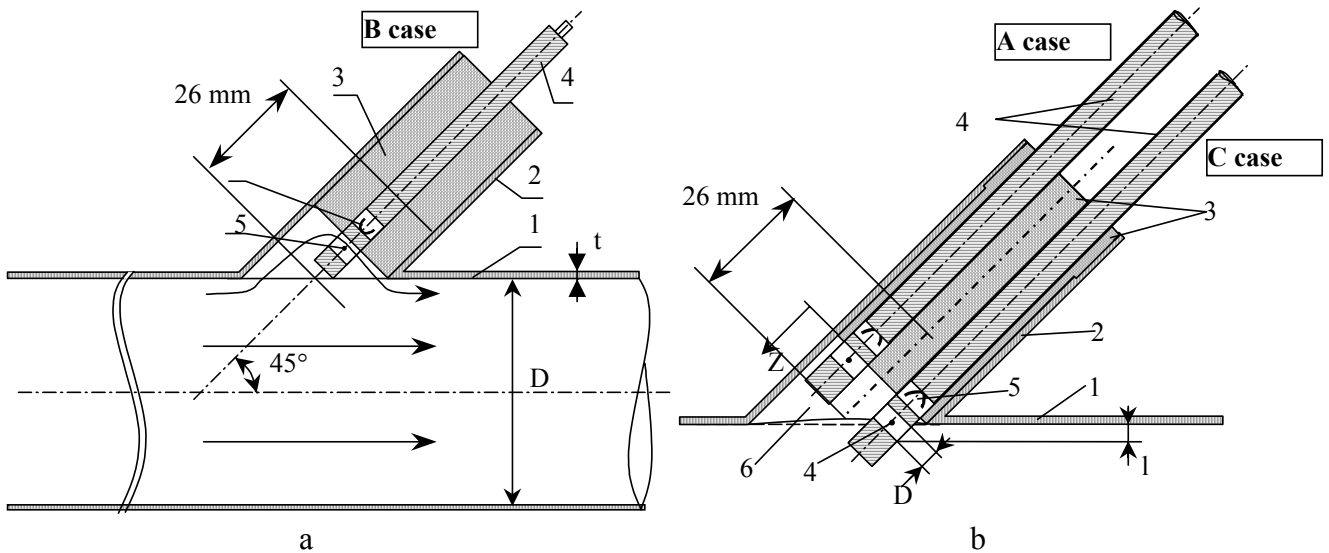

Fig. 6. Measurement of flow velocity in the recesses: a-along acoustical axis of the transducer; b-at the maximal and minimal depth

To ensure a space for scanning the recesses and to inspect flows at the bottom of the recess, the mock-ups were shifted 26 mm deeper. Three positions were chosen for scanning. First of all scanning along the acoustic axis of the transducer in the recess was performed (Fig.6a, case B). The second, scanning in the deeper path of the recess (Fig.6b, case A) and the third, in the shallow part of the recess (Fig.6b, case C) were carried out.

The measurement results in the upstream recess (case B) are shown in Fig.7. The value of flow velocity in the various depth of recess has complicated dependence, which characterises aerodynamic properties of the recess space and depends on the flow velocity in the pipe. If the flow velocity in the pipe is less 1 m/s, a velocity flow (curve 1 in Fig.7) is monotonously increasing from $l_n=5\text{mm}$. For fast flows in the pipe, the values of flow velocity above the surface of transducer considerably increases. However at 4 mm from the surface of the transducer flows velocity is minimal. Further the flow velocity increases and achieves maximum at 12 mm away from the surface of the transducer. In this region the value of the flow velocity in the recess achieve (30-35)% from the axial flow velocity in the pipe. The last maximum of the flow velocity is at the boundary of the pipe and recess. In this place the flow depends on the properties of a total

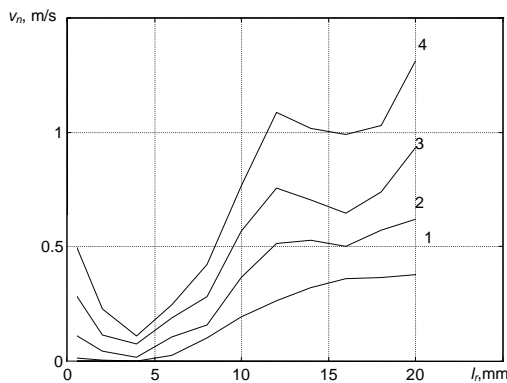

Fig. 7. Flow velocity in the upstream recess along the acoustical axis of a transducer: 1- $v=1$ m/s, 2- $v=2$ m/s, 3- $v=3$ m/s, 4- $v=4$ m/s

flow in the pipe and reveals that it transforms from a laminar to turbulent flow.

The measurement results of the flow velocity in the downstream recess are shown in Fig.8. In this case dependence at the low flow velocity (curve 1 in Fig.8) is similar to dependence at the low flow velocity in the upstream recess (curve 1 in Fig.7), only the values of the flow velocity in downstream recess are bigger. The beginning of the curves 2, 3, 4 (Fig.8.) is similar to the same curves in the upstream recess. At higher flow velocities in the pipe ($v=3$ m/s and $v=4$ m/s) there are

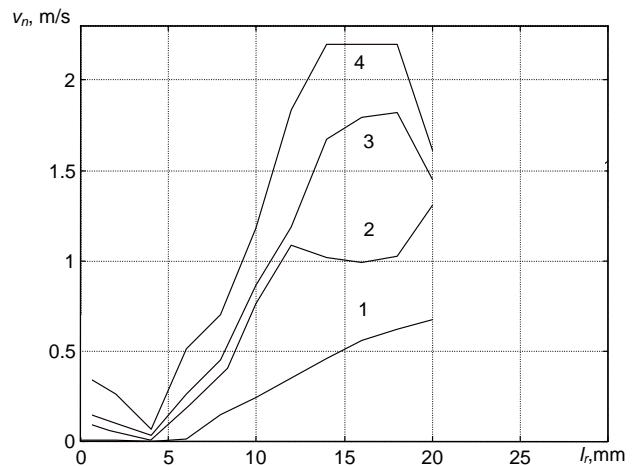

Fig. 8. Flow velocity in the downstream recess along the acoustical axis of a transducer: 1- $v=1$ m/s, 2- $v=2$ m/s, 3- $v=3$ m/s, 4- $v=4$ m/s

maximum in the region 13-17 mm away from the surface of the transducer mock-up. The maximal value of the flow velocity in the recess achieves 50% in comparison with the flow in the pipe.

Measurements in the recess cavity according to Fig.6 b were carried out also upstream. The dependence of the flow velocity more deeply in the recess path (case A) has flow values 2-3 time less (Fig.9 a) in comparison with such values in the centre of the recess (Fig.7). The first minimum of the flow velocity in the recess at different flow velocities in the pipe is not at the same distance from

the surface of transducer. In the shorter recess there are bigger flow velocities (Fig.9 b) and there are not minimum in curve 1, 2, 3.

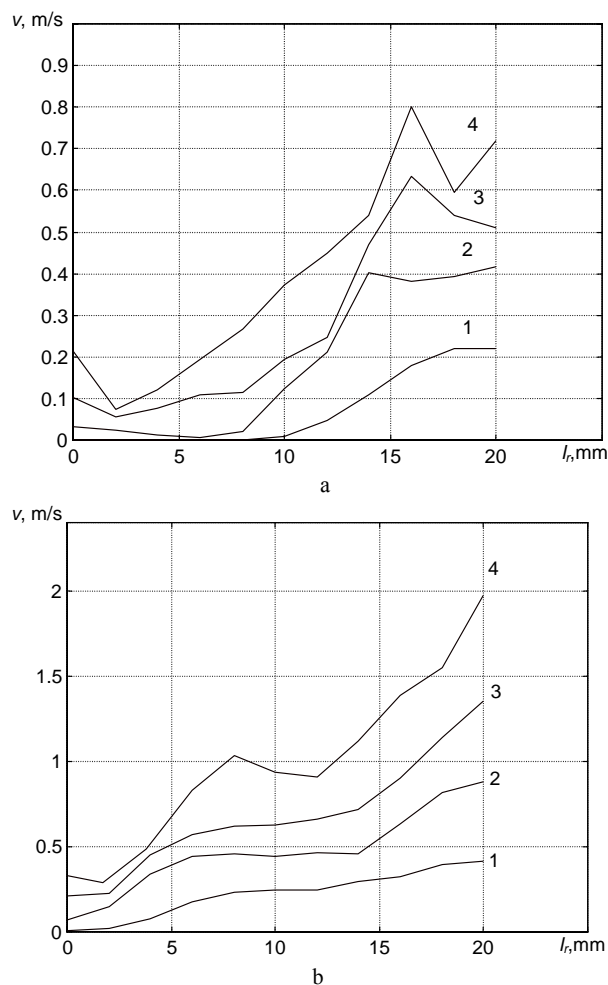

Fig. 9. Flow velocity in the recess cavity: a) in the deeper recess path (A case), b) in the shorter recess path (C case); 1 - $v=1$ m/s, 2 - $v=2$ m/s, 3 - $v=3$ m/s, 4 - $v=4$ m/s

Conclusions

Geometry and shape of transducers recesses depend on the diameter of a transducer, the gap between the transducer housing and the holder of transducer, also on the angle between the centreline of a pipe and the acoustical axis of the transducer. The calculations for variable angles and various diameters of the transducers were performed. The large angle gives small depth of the recess, but it does not provide high accuracy of ultrasonic flow meters.

It was determined that use of the metallic grid decreases flow velocity in the recess of a transducer. This decreasing depends on the density of the grid.

There are differences between flow velocity in upstream and downstream recesses. Near the surface of a transducer the flow velocity is more than two-time bigger than in the upstream recess. However, at bigger distances from the surface of the transducer, the flow velocity is

higher in the downstream recess. In this region the maximal value achieves 50% of the flow velocity in a pipe.

Dependencies of a flow velocity in the recess upon flow velocity are rather complicated. They depend not only on a flow velocity in a pipe, but on aerodynamic properties of a recess cavity also. The first maximum of the flow velocity in the recess is near by the transducer, if the measurements are performed along the acoustical axis of a transducer. After that follows the flow minimum approximately at 4 mm away from the surface of transducer. The last maximum of the flow velocity in the upstream recess (at boundary recess and pipe) shows that flow transforms from laminar to a turbulent flow.

Reference

1. **Lynnworth L. C.** Ultrasonic flow meters. Physical acoustic. New York: Academic press. 1979. P.480-520.
2. **Mylvaganam K.S.** Ultraschall - Durchfluß - messung strömender Gase unter niedrigem Druck für einen breiten Meßbereich./Technisches Messen, 1986, Hef t3, S.112-115.
3. **Хамидулин В. К.** Ультразвуковые контрольно-измерительные устройства и системы. Ленинград: Ленинградский университет. 1989. С.220.
4. **Chen X. Q., Pereira J. C. F.** Computation modelling of dilute gas particle flow in an ultrasonic gas flow meter. Flow Meas. Instrum. 1997. Vol. 8. Nr.3/4. P.167-182.
5. **Froya K.-E., Lunde P.** A ray theory approach to investigate the influence of flow velocity profiles on transit times in ultrasonic flow meters for gas and liquid.
6. **Kochnert H., Melling A., Baumgartner M.** Optical flow field investigation for design improvements of an ultrasonic gas meter. Flow Meas. Instrum. Vol.7. No.3/4. P.133-140.
7. **Kažys R., Vladišauskas A., Raišutis R.** Experimental investigation of gas flow profiles in ultrasonic flow meters. Ultragasas. 2001. Nr.3(40). P.27-35.

R. Kažys, A. Vladišauskas, R. Raišutis

Dujų srauto pjekzeitiklių nišose tyrimai

Reziume

Straipsnyje nagrinėjami lokalojo dujų (oro) srauto greičio ultragarsinių srauto matuoklių pjekzeitiklių nišose matavimo rezultatai. Atliktas nišų parametrų įvertinimas, kai kinta pjekzeitiklių skersmuo ir kampas tarp ultragarso spindulio ašies ir vamzdžio ašinės linijos.

Esant didesniems kampams, sumažėja nišų gylis, tačiau sumažėja ir matavimo tikslumas.

Buvo atlikti dujų srauto matavimai nišoje, atitvertoje metaliniu tinkleliu ir be jo. Tinklelis apsaugo nišas nuo dujų srauto tekėjimo prie pjekzeitiklio paviršiaus, kai srauto greitis vamzdyje yra mažesnis negu 2 m/s. Srauto greičiui vamzdyje didėjant, tinklelis, priklausomai nuo tankio, srauto greitį ties pjekzeitiklio paviršiumi sumažina 0,2 m/s.

Išmatuotos dujų srauto greičio nišose priklausomybės nuo srauto greičio vamzdyje ir nišos padėties srauto atžvilgiu. Matavimo rezultatai parodė, kad dujų srauto greičiai nišoje prieš srautą ir srauto kryptimi yra skirtingi ir tai turi įtakos dujų srautui vamzdyje. Esant mažiems dujų srauto greičiams vamzdyje, dujų srautai nišoje išilgai akustinio kanalo nuolat didėja nuo pjekzeitiklio paviršiaus iki ribos su vamzdžiu. Esant dideliems srautams vamzdyje, dujų srautai nišose turi sudėtingas priklausomybes. Dideli srauto greičiai susidaro ties pjekzeitiklio paviršiumi. Po to eina srauto greičio minimumas (4 mm nuo paviršiaus) ir toliau srauto greičio didėjimas priklauso nuo nišos padėties srauto atžvilgiu.

Pateikta spaudai 2002 06 18

DOI: 10.5755/j01.u.43.2.8116