

Digital signal processing in ultrasonic multi-channel measurements

G. Armanavičius, R. Kažys

Prof. K. Baršauskas ultrasound institute

Kaunas University of Technology

Introduction

During automation of industrial processes, imaging of an environment and detection of targets is becoming more and more important. For this purpose ultrasonic systems based on distance measurements may be efficiently exploited. Generic block diagram of such a system is presented in Fig. 1 [1].

The main idea of this system is that measuring signals simultaneously are sent to and received from different directions. This allows us to reduce measurement time proportionally to the number of measurement channels [1,2]. In this system, during the process of multi-channel distance measurements, the main problem, which is met, is the following: after sending simultaneously several signals in different directions to the receiver arrive several signals from the different directions with different amplitudes. In order to resolve these signals, e.g., to extract only one necessary type of the signal from the mixture of received signals it is necessary to use a set of quasi - orthogonal signals. The number of the required different signals is increasing with the number of distance measurement channels and with the number of simultaneously operating systems.

To solve the above-mentioned problems it was decided to use pseudo-noisy (PN) signals [1, 2].

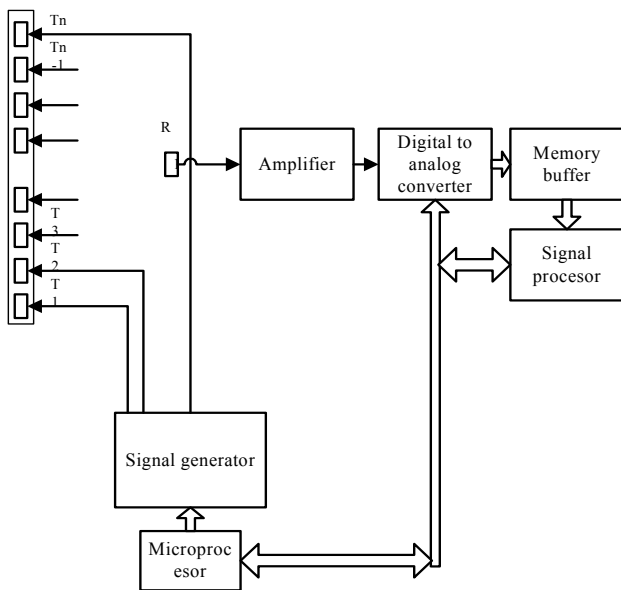

Fig.1. Generic block diagram of ultrasonic multi-channel distance measurement system: T_1 - T_n are transmitters, R is a receiver of ultrasonic waves

Single pseudo-noisy signals, such as Gold, Kasami, M-sequences and others are described in [4, 5] and are widely used in telecommunications. But before analysis of the mentioned signals requirements to measuring signals must be formulated.

Requirements to measurement signals

There are two different measurement tasks met in practice:

1. Simultaneous measurement of distances between one given reference point and several reflectors.
2. Simultaneous measurement of the distance between several reference points and several reflectors.

From the point of view of measurement it possible to distinguish two different types of an environment [2]:

1. Environment with many dense reflectors in comparison with the width of the main peak of the auto correlation function of PN-sequence.
2. Environment with sparse reflectors in comparison with the width of the peak of autocorrelation function of the PN-sequence.

In order to perform accurate and reliable simultaneous measurements with a good spatial resolution in an environment with many reflectors, the measurement signals must fulfill the following requirements:

1. Narrow auto correlation function with respect to the dimensions of reflectors.
2. The level of auto correlation function side lobes must be close to zero.
3. Cross - correlation function between any different measurement signals should be close to zero.
4. Measurement signals should be as short as possible.
5. A number of measurement signals meeting the above listed requirements in the same family set should.

Parameters of the PN sequences

In order to fulfill the above formulated requirements investigation of well known PN sequences was carried out. For analysis four PN families of coded sequences were chosen:

1. Gold sequences,
2. Short Kasami sequences,
3. Large Kasami sequences,
4. M – Sequences.

These sequences are characterized by following parameters [2, 4]:

Autocorrelation function is given by

find sequences that will match the all requirements for measurement signals. For that reason it five optimization criteria were chosen:

1. Least side lobe / auto optimal (LSE/AO) criterion.
2. Auto optimal / least side lobe (AO/LSE) criterion.
3. Maximal side lobe energy / auto optimal (MSE/AO) criterion.
4. Mean square cross correlation / cross optimal (MSQCC/CO) criterion.
5. Cross optimal / mean Square cross correlation (CO/MSQCC) criterion.

These criteria are given elsewhere [1, 3] and therefore they will not be discussed here. In Fig. 2 - 5 non optimized and optimized, using CO/MSQCC optimization criteria auto and cross correlation functions of Short Kasami PN code sequences are presented. As it can be seen from Fig. 2 – 5, during optimization of the code sequences reduction of the level of side lobes of an auto correlation function and reduced level of a cross correlation function between two code sequences were achieved.

In Fig. 6 and 7 cross correlation function values in a set of the analyzed PN sequences are presented.

$$R_a(\tau) = \int_{-NcT_c/2}^{NcT_c/2} pn(t)pn(t+\tau)dt, \quad (1)$$

where: $NcT_c = T_s$, N_c is the number of elements of PN signal, T_c is the length of one element of the signal, T_s is the duration of the whole PN signal.

Cross correlation function:

$$R_c(\tau) = \int_{-NcT_c/2}^{NcT_c/2} pn_i(t)pn_j(t+\tau)dt. \quad (2)$$

After analysis of the Gold, Short Kasami, Large Kasami and M - sequences the following conclusions were made:

1. There a lot of sequences meeting only some of the requirements for the measurement signals.
2. Different PN sequence families are characterized by different autocorrelation and cross correlation parameters.
3. Distortions of the auto and cross correlation parameters of the sequences in a family are very big, from few percents up to several times.

After evaluation of the above listed conclusions it was made decision to make optimization of code sequences to

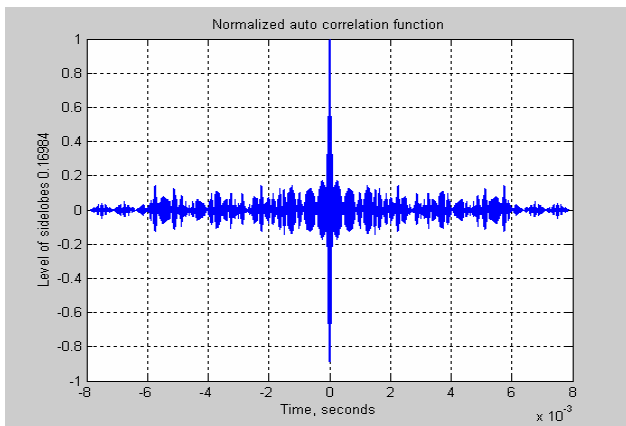

Fig.2. Normalized auto correlation function of the non optimized Short Kasami sequence, the sequence length 63 elements

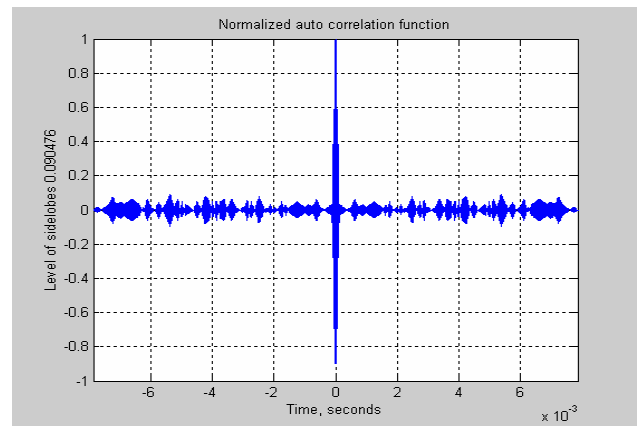

Fig.3. Normalized auto correlation function of the optimized Short Kasami sequence, the sequence length 63 elements

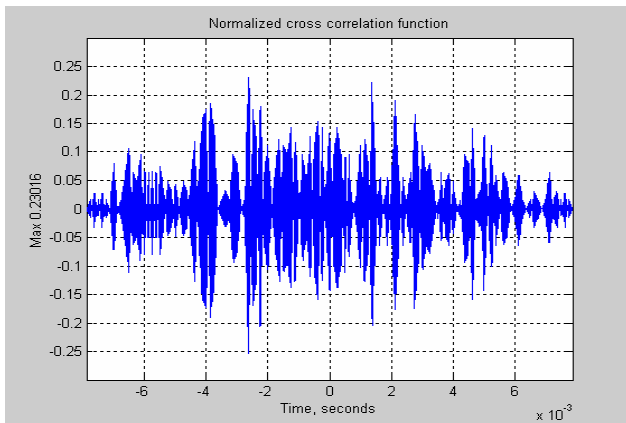

Fig.4. Normalized cross correlation function between the two non optimized Short Kasami sequences, the length of sequences is 63 elements

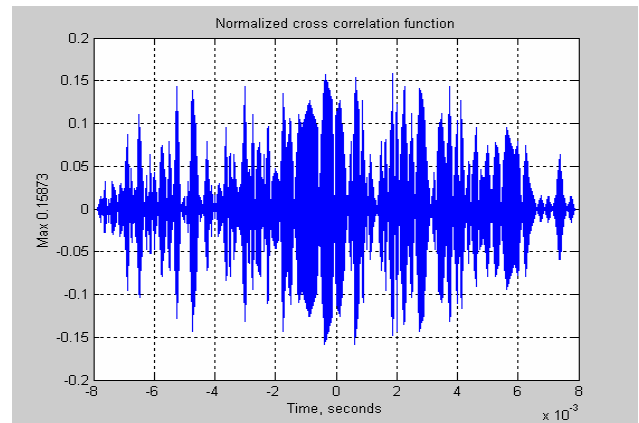

Fig.5. Normalized cross correlation function between the two optimized Short Kasami sequences, the length of sequences is 63 elements

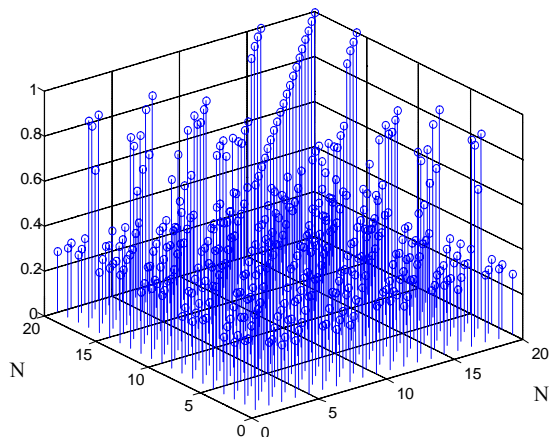

Fig.6. Normalized maximal cross correlation values between the optimized Gold sequences, all sequences are from the same family set: N is the sequence number, the length of sequences is 63 elements

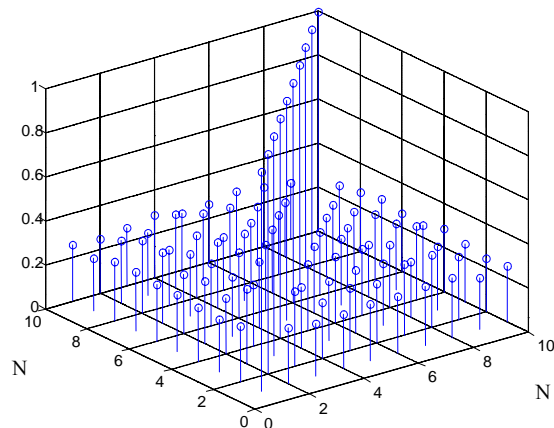

Fig.7. Normalized maximal cross correlation values between the optimized Short Kasami sequences, all sequences are from the same family set: N is the sequence number, the length of sequences is 63 elements

After investigation of the optimized PN code sequences the following conclusions were made:

1. The lowest level of side lobes was obtained during analysis of the Gold code sequences. But at the same time these sequences are not suitable at all due to their high similarity and bad cross-correlation properties.
2. The best-set features characterize short Kasami code sequences, optimized using the CO/MSQCC optimization criteria. The level of side lobes is just a bit higher than in the Gold code sequences, but cross-correlation features are much better and the choice of code sequences with the same length is significantly wider.

Digital signal processing

During optimization of the PN code sequences quite good results were achieved, e.g. a level of side lobes of an auto correlation function and a level of a cross correlation function of PN code sequences were reduced. After evaluation of these results it was made decision that in real a situation, during multi-channel measurements each measurement channel will receive measurement signals not only transmitted by this same channel, but also transmitted by other channels, what will create a correlated noise. After evaluation of influence of correlated noise to detection of PN code sequences in a correlated noise it was shown that depending on the length of a sequence it can be simultaneously used from 6 to 12 different PN code sequences. In order to perform high accuracy robust in such a situation it was decided to develop the digital signal processing algorithm.

In order to evaluate the possibility to extract the reference signal $x_{atr}(t)$ from the sum $S_{sum}(t)$ of received signals the calculation of the normalized cross correlation function, between the reference signal and the received signal and a correlated noise is performed:

$$R_{x_{ztr}S_{sum}} = \frac{\int_{-T_{ks}}^{T_{ks}} x_{atr}(t)S_{sum}(t)dt}{E_{x_{atr}S_{sum}}}, \quad (3)$$

where: $E_{x_{atr}S_{sum}}$ is the energy of the reference signal and the sum of the received signals.

If during this calculation difference between central peak of cross correlation function is much more bigger than the level of side lobes

$$\max(R_{x_{ztr}S_{sum}}) \gg \max_{sl}(R_{x_{ztr}S_{sum}}),$$

then this reference signal can be extracted from a mixture of the signal and a correlated noise and it is not necessarily to make digital signal processing. Otherwise $\max(R_{x_{ztr}S_{sum}}) < \max_{sl}(R_{x_{ztr}S_{sum}})$, the reference signal is impossible to extract from the signal and a correlated noise and it is necessarily to apply digital signal processing. This performed in the following way: calculation of the normalized cross correlation function between the signal of correlated noise and all expected PN sequences is performed:

$$R_{x_iS_{sum}} (i = 1 : N_{ss}) = \frac{\int_{-T_{ks}}^{T_{ks}} x_i(t)S_{sum}(t)dt}{E_{x_iS_{sum}}}, \quad (4)$$

and the sequence with the highest $\max(R_{x_{ztr}S_{sum}}(i))$ correlation value with the mixture of signal is found. If it is not the reference signal then ten new PN code sequences are calculated $x_j(t) = x_i(t)(0.1n)$, where $n = 1 : 10$. After that calculation the normalized cross correlation function between signal of correlated noise and calculated PN sequences with different amplitudes is calculated:

$$R_{x_iS_{sum}} (j = 1 : 10) = \frac{\int_{-T_{ks}}^{T_{ks}} x_i(t + \tau)S_{sum}(t, j)dt}{E_{x_iS_{sum}}}, \quad (5)$$

and the PN sequence with the highest correlation value with signal of correlated noise is found $\max(R_{x_{ztr}S_{sum}}(j))$. After this calculation it is possible to eliminate this PN sequence from the signal of correlated noise:

$$S_{sum}(t, j) = S_{sum}(t) - x_i(t + \tau)a_i. \quad (6)$$

When elimination of the PN sequence from the signal of correlated noise is done the calculation of cross correlation between a new signal and the reference signal is performed:

$$R_{x_{ztr}S_{sum}} = \frac{\int_{-T_{ks}}^{T_{ks}} x_{atr}(t - \tau)S_{sum}(t)dt}{E_{x_{atr}S_{sum}}}. \quad (7)$$

If during this calculation the difference between central peak of cross correlation function is much bigger than a level of side lobes

$$\max(R_{x_{ztr}S_{sum}}) \gg \max_{sl}(R_{x_{ztr}S_{sum}}),$$

then we assume that the reference signal can be extracted from the signal - correlated noise mixture and it is not necessary to make digital signal processing. Otherwise $\max(R_{x_{ztr}S_{sum}}) < \max_{sl}(R_{x_{ztr}S_{sum}})$, the reference signal is impossible to extract from signal - correlated noise mixture and it is necessary to proceed from formula (4) until results that will satisfy $\max(R_{x_{ztr}S_{sum}}) \gg \max_{sl}(R_{x_{ztr}S_{sum}})$ will be achieved.

Results of digital signal processing

The proposed algorithm was checked using both simulated and real signals:

1. Without delay of simulated PN sequences in the time domain $\tau = 0$ and amplitudes of PN sequences were set to $a_i = 1$.
2. With a random delay of the simulated PN sequences in the time domain $\tau_i = rand$ and random amplitudes of the PN sequences $a_i = rand$.
3. With real measurement signals received by the multi channel distance measurement system [2].

The simulation of the signals was performed in following way. After choosing parameters of PN sequences (family type and length of sequences N) for the digital signal processing, frequency of measurement signal f_{ns} , which can vary from 10kHz to 5MHz, and calculation of period of measurement frequency $T_{ns} = 1/f_{ns}$, calculation of the length of the sequences are made $T_{ks} = T_{se}N$, where T_{se} is the length of one element of the sequence, which can vary from $1T_{ns}$ to $20T_{ns}$. After that the number of discrete samples is $n = T_{ks}/T_{dis}$, where $T_{dis} = 1/f_{dis}$ and f_{dis} is sampling frequency, which can vary from $5f_{ns}$ to $100f_{ns}$. Now

discrete time scale is introduced $t = (n-1)T_{dis}$, where $n_{dis} = 1:n$.

After the discrete time and all parameters of the PN sequence are calculated it is possible to generate a sequence:

$$x_i(t) = a \sin(2\pi f_{nes}t + KSS_i\pi), \quad (8)$$

where: a – is the amplitude of the signal, KSS_i - code sequence, i is the sequence number.

When the coded sequences are calculated, one sequence from the set of PN sequences is marked as a reference PN sequence $x_{atr}(t) = x_i(t)$. After that the mixture of the received signals with various amplitudes correlated noise is calculated:

$$S_{sum}(t) = \sum_1^n (x_i(t + \tau)a_i) + x_{atr}(t + \tau)a_i, \quad (9)$$

where: a_i is the amplitude of the PN sequence, which can vary from 0.1 to 1, τ is delay time, which can vary from 0 to $5T_{ks}$.

The results for the first type of signals are presented in Fig. 8–13. In Fig. 8 the normalized cross correlation function between the mixture at signals, which was calculated summing 10 PN code sequences, and the reference signal, shown in Fig.11 is presented. As we can see from Fig.8 it is impossible to extract the reference signal from the sum of signal, because the central peak is much lower than the level of side lobes $\max(R_{x_{ztr}S_{sum}}) < \max_{sl}(R_{x_{ztr}S_{sum}})$. In Fig.9 is shown the normalized cross correlation function between the received mixture of signal and the reference signal after digital signal processing is shown. As we can see now the reference signal can be extracted from the sum of different PN sequences. In this situation the algorithm was run 9 times to eliminate all 9 PN sequences from the received signal. It was done for evaluation of effectiveness of the presented algorithm. For this purpose in Fig.10 the normalized auto correlation function of the reference signal is presented. As we can see Fig.10 and Fig.9 are identical it means, that the presented algorithm is working properly. For more precise evaluation of the algorithm the signal which consists of 60 PN coded sequences was applied. The normalized cross correlation function between this signal and the reference signal before and after digital signal processing is presented correspondingly in Fig.12 and Fig.13.

For evaluation of performance of the algorithm in a real situation it the signal consisting of 10 PN code sequences, randomly shifted in the time domain and with random amplitudes was processed. The results of this analysis are presented in Fig.14 and Fig.15. As we can see from the results presented before digital signal analysis it is impossible to extract the reference signal from the mixture of signals because $\max(R_{x_{ztr}S_{sum}}) < \max_{sl}(R_{x_{ztr}S_{sum}})$. After digital signal processing we have got a situation when $\max(R_{x_{ztr}S_{sum}}) \gg \max_{sl}(R_{x_{ztr}S_{sum}})$. The achieved

results are a little bit worse than in the first case. The main reason of such results is that the PN code sequences are not orthogonal, but quasi – orthogonal, so during digital signal processing it is impossible to calculate exact amplitudes of PN sequences in the received signal and for this reason it is impossible to eliminate completely PN sequences from the mixture of the signal.

The last analysis of the algorithm was performed using signals received by the real multi-channel distance measurement system. The reference signal for this case is presented in Fig.16 and the normalized auto correlation function of the reference signal is presented in Fig.17. As we can see the reference signal is much more complicated than the ideal reference signal presented in Fig.11. That happens after bandwidth limitation and distortion of waveforms in ultrasonic transducers. On the other hand the normalized auto correlation function of the reference signal, is almost the same as in an ideal situation (Fig.17).

During this analysis the mixture of PN signals was calculated summing up four PN code sequences received by the multi-channel distance measurement system. The results before digital signal processing and after digital signal processing are presented in Fig. 18 and Fig. 19. As we can see from the presented figures after digital signal processing the level of central peak was increased and the

level of side lobes was decreased, what indicates a good performance of the algorithm.

Conclusions

1. The analysis of the proposed digital signal processing algorithm showed that using the algorithm it is possible to increase the number (depending from the length of the sequences from 2 to 5 times) of measurement channels in multi-channel distance measurement system.
2. Using optimization of PN code sequences and the presented algorithm of digital signal processing it is possible to increase (depending on the length of the PN sequences) from 4 to 8 times the number of measurement channels of multi-channel distance measurement system.
3. Using more a complicated algorithm it is possible to achieve a little better results, in comparison with the results achieved, but in that case the calculation time and price of a hardware will not justify improvement of the results.

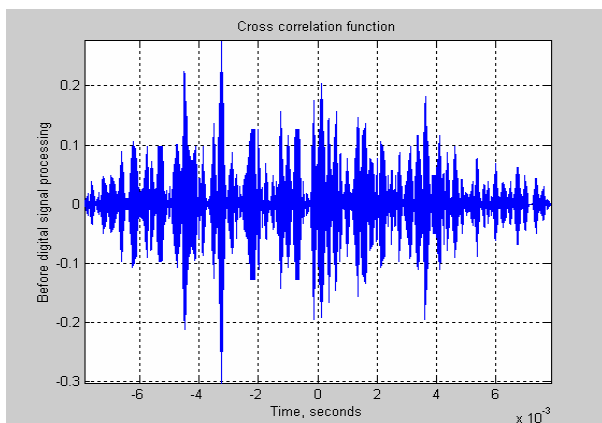

Fig.8. Normalized cross correlation function between the mixture of PN signals and the reference signal before digital signal processing. Signal is calculated summing up 10 PN code sequences

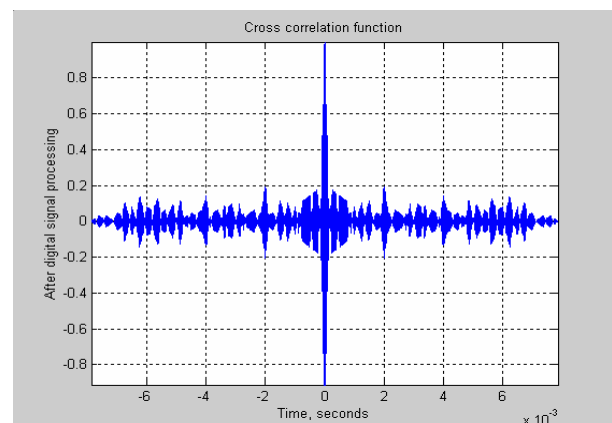

Fig.9. Normalized cross correlation function between mixture of PN signals and the reference signal after digital signal processing. Mixture of signals is calculated summing up 10 PN code sequences

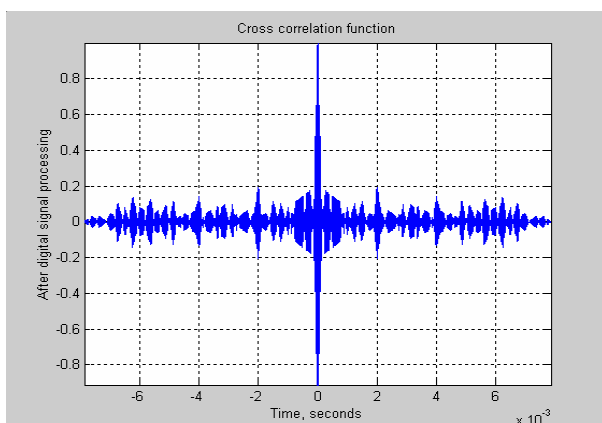

Fig.10. Normalized auto correlation function of the reference signal

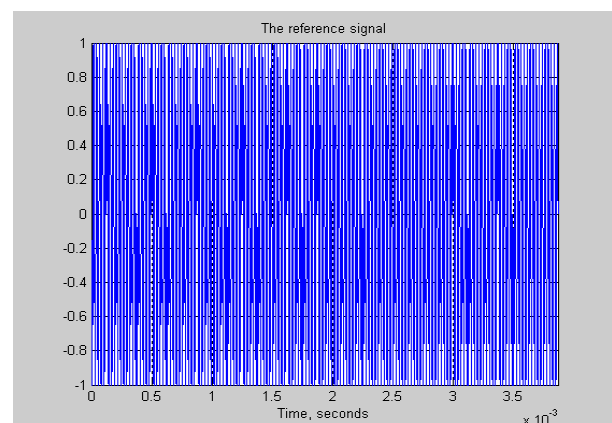

Fig.11. The reference signal

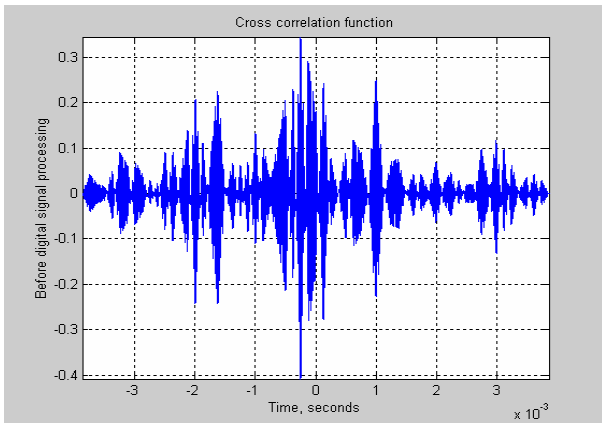

Fig.12. Normalized cross correlation function between the mixture of 60 PN- signals and the reference signal before digital signal processing

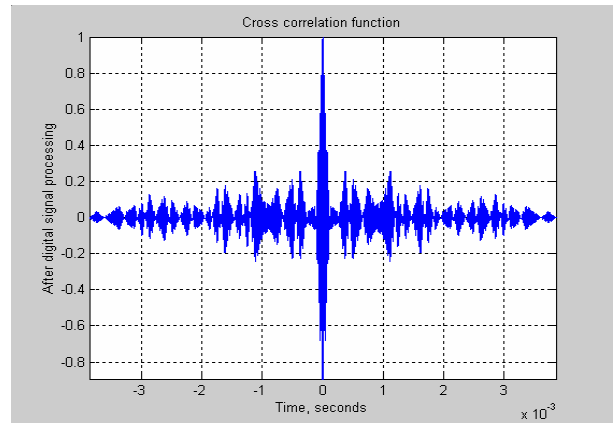

Fig.13. Normalized cross correlation function between the mixture of 60 PN- signals and the reference signal after digital signal processing

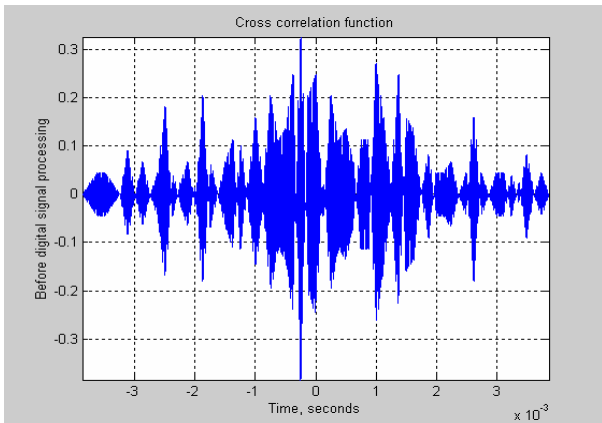

Fig.14. Normalized cross correlation function between the mixture of 10 PN- signals and the reference signal before digital signal processing

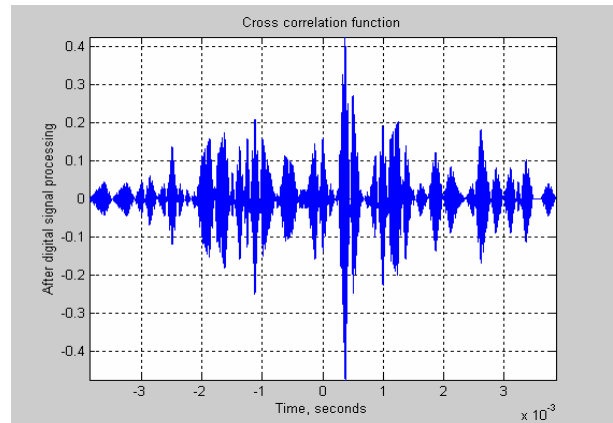

Fig.15. Normalized cross correlation function between the mixture of 10 PN- signals and the reference signal after digital signal processing

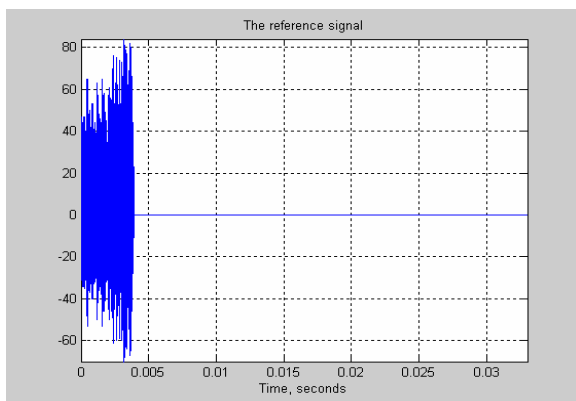

Fig.16. The reference signal

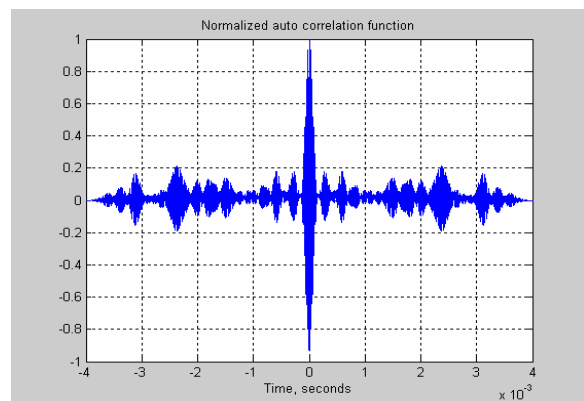

Fig.17. Normalized auto correlation function of the reference signal

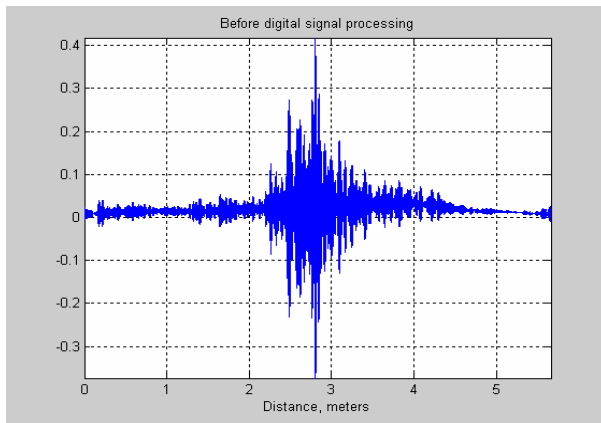

Fig.18. Normalized cross correlation function between the mixture of PN- signals and the reference signal before digital signal processing

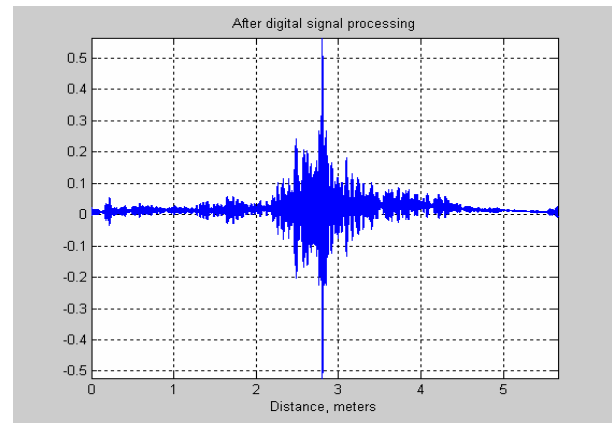

Fig.19. Normalized cross correlation function between the mixture of PN- signals and the reference signal after digital signal processing

References

1. **Kažys R., Svilainis L., Mažeika L.** Application of orthogonal ultrasonic signals and binaural processing for imaging of the environment. *Ultrasonics*. 2000. Vol.38. No.1-8. P.171-175.
2. **Kažys R.** Smart systems for robot vision. Proceedings of the 5th International Symposium on Methods and Models in Automation and Robotics. Miedzyzdroje, Poland. 1998. Vol.3. P.827-832.
3. **Armanavičius G.** Parameters of spread spectrum signals. *Ultrasound* 2000. Vol.35. No.2. P.40-45.
4. **Karkkainen K.** Comparison of the performance of some linear spreading code families for asynchronous DS/SSMA systems. *IEEE Trans. on Com.* 1991. Vol. MilCom 2. P.784-790.
5. **Armanavičius G., Kažys R.** Analysis of pseudo noise sequences for multi channel distance measurements. *Ultragarsas*. 2000. Vol. 37. No. 4.
6. **Meel J.** Spread Spectrum. Sirius Communications. Belgium. 1999. Vol. 2.
7. **Niederdrank T.** Maximum length sequences in non-destructive material testing: application of piezoelectric transducers and effects of time variances. *Ultrasonics*. 1997. Vol.35. P.195-203.
8. **Mayer K., Marklein R., Langenberg K. J. and Krutter T.** Three – dimensional imaging system based on Fourier transform synthetic aperture focusing technique. *Ultrasonics*. 1990. Vol.28. P.241-255.
9. **Karkkainen K.** Influence of various PN sequence phase optimization criteria on the SNR performance of an asynchronous DS-CDMA system. *IEEE Trans. on Com.* 1995. P.641-646.

G. Armanavičius, R. Kažys

Kvaziortogonalinių signalų panaudojimas daugiakanaliams atstumo matavimams

Reziumė

Kodinės sekos daugiakanalėse atstumo matavimo sistemose dėl jų pakankamai gerų atskiriamumo savybių leidžia atlikti atstumo matavimus daugeliu krypčių vienu metu. Tai labai supaprastina daugiakanalę atstumo matavimo sistemą ir pagreitina matavimus. Šiose sistemose naudojamos kodinės sekos, taikomi tokie kokybiniai kriterijai kaip siaura autokoreliacinė funkcija, žemas autokoreliacinės funkcijos šoninių lapelių lygis, tarpusavio koreliacijos funkcija artima nuliui, kiek įmanoma trumpesnės sekos, išlaikant prieš tai išvardytus reikalavimus ir kodinių sekų rinkinys ar šeima susideda iš daugelio sekų, tenkinančių išvardytus reikalavimus. Kodinių sekų analizei sudaryta kompiuterinė programa, kuri leidžia parinkti kodines sekas, atitinkančias išvardytus kokybinius kriterijus, ir analizuoti gautus sekų kokybinius parametrus. Tačiau, atlikus kodinių sekų optimizavimą bei išanalizavus galimybę panaudoti šias kodines sekas realioje daugiakanalėje atstumo matavimo sistemoje, susidurta su problema, kai vienu metu galima panaudoti tikrai labai nedidelį skaičių šių kodinių sekų. Siekiant išspręsti šią problemą, buvo sudarytas skaitmeninių signalų apdorojimo algoritmas, leidžiantis kartais padidinti vienu metu naudojamų kodinių sekų skaičių, kartu ir daugiakanalės atstumo matavimo sistemos matavimo kanalų skaičių.

Pateikta spaudai 2002 07 8

DOI: 10.5755/j01.u.43.2.8118