

Air gap modelling and control possibilities in rotary systems

R. Mikalauskas, V. Volkovas

Technological System Diagnostic Institute, Kaunas University of Technology

Kęstučio str. 27, Kaunas 3004, Lithuania; Tel/Fax: +370 7 323 720; e-mail: romika@ktu.lt

Introduction

Generators of hydraulic turbines are electro-machine converters (EMC) with air gap asymmetry which influence the quality of generation process and characterises the technical condition of the generator. Therefore control over one of the most important EMC quality parameters, i.e. the monitoring of an air gap between the stator and rotor, is very important. The air gap asymmetry may be caused by the building, dynamic eccentricities, cone rotor, ellipse shaped surfaces of the stator and rotor and other factors [1]. Technological inaccuracies resulting in an eccentricity are practically impossible to avoid in a production process [2]. During EMC operation the eccentricity tends to grow.

Eccentricity caused by air gap asymmetry in EMC increases the general level of noise and vibration, induces one side magnetic traction force, which shortens the service life of bearings and decreases the unit reliability in general [3]. A large number of works about the influence of air gap asymmetry on EMC characteristics and parameters proves that air gap asymmetry is EMC related problem.

While discussing the efficiency and safe operation of generators specialists agree on the necessity to supervise an air gap in generators, i.e. on demand to equip the control system with air gap monitoring. As no condition monitoring system can be designed and produced without the component integrity and optimal parameters analysis this work was intended to develop a theoretical basis for design of an air gap measurement converter. The prepared mathematical model of a rotary system with an air gap and the results of theoretical investigation could be helpful in creation a realistic model of converter and its testing in the future.

Aspects of methods applied to air gap measurements in electrical machines

The methods applied for measurements of an air gap in electrical machines can be divided in two groups:

- methods which ensure air gap measurement during machine operation;
- methods which ensure air gap measurement in machines at the final stage of production process (alternatively, air gap measurement is performed during certain operation periods).

Almost all air gap measurement methods applied to an operating machine can be applied to carry out testing and diagnostics at the final stage of production process. Technical literature describes several varieties of converters used in air gap measuring systems, i.e. inductive, capacitive, optical, galvanometrical, ultrasonic

converters. The selection of a particular converter is related to different problems, e.g. electrical machine design, operating conditions, measurement accuracy, measurement complexity, machine dimensions, cost, operation reliability etc. Figure 1 presents a classification diagram for air gap measuring systems and installations in electrical machines. The classification diagram refers both to operating machines and to testing period.

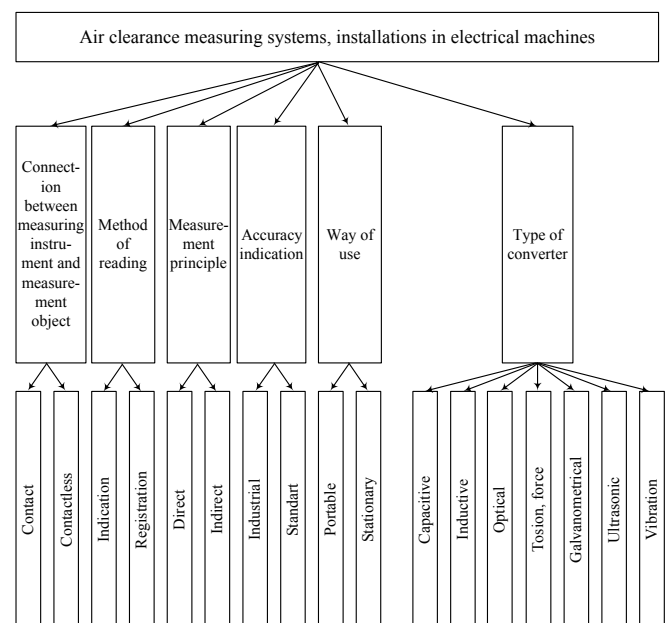

Fig. 1. Classification diagram presenting air gap measuring systems and installations in EMC

To measure an air gap in monitoring systems and installations contactless, unpretentious converters, which could function in extreme magnetic environment are preferable. As the converter is intended to measure the air gap in a dynamic mode it must be very sensitive and low inertial. The mentioned features are characteristic of capacitive converters of distance. These converters can differ in shape, size and design. The main parameters and characteristics which determine the converter's suitability for measuring and monitoring, diagnostics systems are as follows: 1) transfer function of the converter; 2) relation between the converter's output signal and electrodes' geometrical dimensions and their position in respect of each other; 3) the converter's sensitivity with different values of transmitting electrode's excitation signal. To analyse the above mentioned characteristics and parameters a converter's mathematical model was proposed in which the finite element method was applied.

The flexible model provides a solution, which could be helpful in designing converters that meet specific requirements with a possibility to optimise them in accordance with the design of a controlled machine. The first stage of design process could comprise the preparation and analysis of the converter's mathematical model as well as of technical issues related to its production.

Schematic circuit of converter for air gap measurement

The converter described in this work is based on electrical fields principle. The converter consists of two electrodes, which are insulated from each other and shielded from the base. An oscillator in the signal processing block sends a high frequency voltage signal to the signal transmitting electrode.

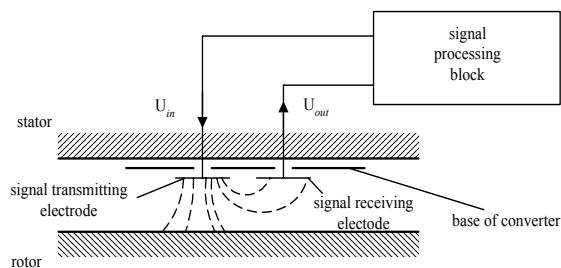

Fig. 2. System for air gap measurement between rotor and stator. Schematic circuit of converter operation

When an electrical field is generated, a part of it falls upon the receiving electrode and thereby the circuit of receiving electrode is fed. The distance between the converter and the rotor surface influences the connection between the transmitting and receiving electrodes' electrical fields. Thus the signal (voltage) in the converter's output is proportional to the distance between the rotor and stator. According to the Maxwell equation the electrical field conforms to the following conditions:

$$[\varepsilon] \frac{\partial^2 \vec{E}}{\partial t^2} + [\sigma] \frac{\partial \vec{E}}{\partial t} + \nabla \times [\nu] \nabla \times \vec{E} = - \frac{\partial \vec{J}_s}{\partial t} \quad (1)$$

where \vec{E} is the electric field, \vec{J}_s is the source current density; $\nabla \times$ is the curl operator; $[\varepsilon]$ is the permittivity matrix; $[\sigma]$ is the electrical conductivity matrix; $[\nu]$ is the reluctivity matrix. Interpretation of the above equation in finite elements results in the following matrix equation of dynamics:

$$[M] \frac{\partial^2 \{A_x\} + [C] \frac{\partial \{A_x\} + [K] \{A_x\} = \{F\},$$

$$[K] = \int_V (\nabla \times [W]^T)^T [\nu] (\nabla \times [W]^T) dv, \quad (2)$$

$$[C] = \int_V [W][\sigma][W]^T dv,$$

$$[M] = \int_V [W][\varepsilon][W]^T dv,$$

$$\{F\} = - \int_V [W] \frac{\partial \{J_s\}}{\partial t} dv.$$

here $\{A_x\}$ are the components of electrical field; $[W]$ is the vector of shape functions; $[K]$ is the matrix of rigidity; $[C]$ is the matrix of damping; $[M]$ is the matrix of mass; $\{F\}$ is force vector. Harmonic solution of the above presented formulation provides degree of freedom values of $\{A_x\}$ for all modes in the solution area.

FEM based converter model and its calculation results

The software package "ANSYS 5.5.1" including finite elements method was used to solve the above mentioned task. A harmonic electromagnetic analysis of the converter's plane model (2-D) was performed. The model was based on the presumption that the electrical saturation of substances was low in the given case therefore a linear harmonic analysis was performed by assuming that permittivity characteristics were constant. The general procedure for the problems solution was as follows: 1) model preparation; 2) applying of loads; 3) voltage calculation on the receiving electrode by using mathematical model; 4) analysis of the obtained results.

The converter's model was constructed by using the plane elements PLANE13, which enabled to solve structural, piezoelectric, thermal, magnetic and electrical problems [4]. The element PLANE13 is determined by four nodes, each of which can have four degrees of freedom. While modelling B-H curves or permanent magnet demagnetization curves this element demonstrates non-linear magnetic features. In structural analysis this element is characteristic of large deformation qualities. By using the PLANE13 elements the physical medium of converter was created and the qualities of substances were ascribed. Hereunder the characteristics of substances used for the converter's components and the characteristics of physical medium are presented Table 1[5]:

Table 1.

	Relative permeability	Electrical resistivity, Ω
Air gap	1	0.1e+14
Rotor	500	2.5
Stator	500	1.0
Converter base	4.0	4.0e+12
Converter electrodes	500	0.5

Fig. 3 presents the converter's BEM model.

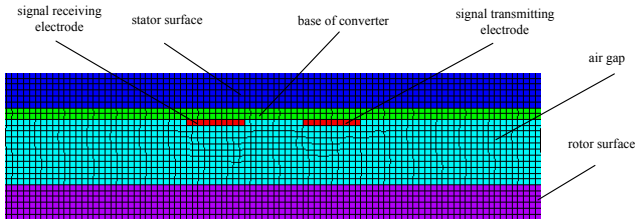

Fig. 3. Converter's calculation 2-D model made of elements PLANE13

The system was excited by means of a high frequency voltage through the converter's transmitting electrode and the voltage in the signal receiving electrode was registered. Depending on a task the model was modified as follows: there was changed the distance between the rotor surface and electrodes' plates in the converter, the distance between the electrodes' plates, the height of electrodes' plates, the width of electrodes' plates. The results are presented in Fig. 4 to 9.

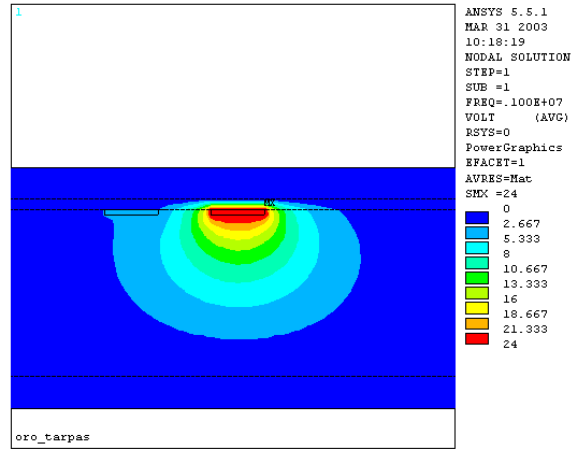

Fig. 6. Voltage values in converter's electrodes and in air gap. Excitation frequency 1 MHz, excitation voltage 24 V, distance between electrodes – 10 mm, distance between stator and rotor – 30 mm.

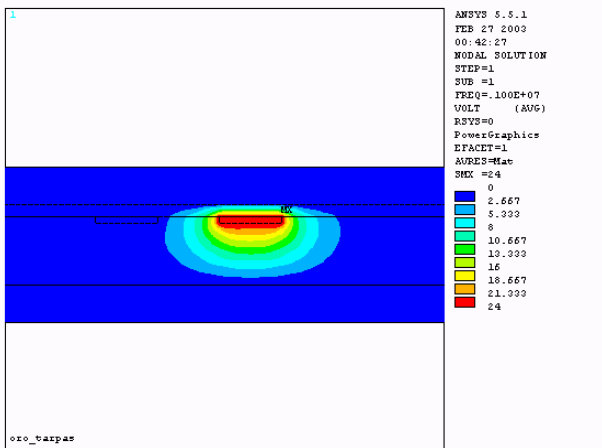

Fig. 4. Voltage values in converter's electrodes and in air gap. Excitation frequency 1 MHz, excitation voltage 24 V, distance between electrodes – 10 mm, distance between stator and rotor – 10 mm.

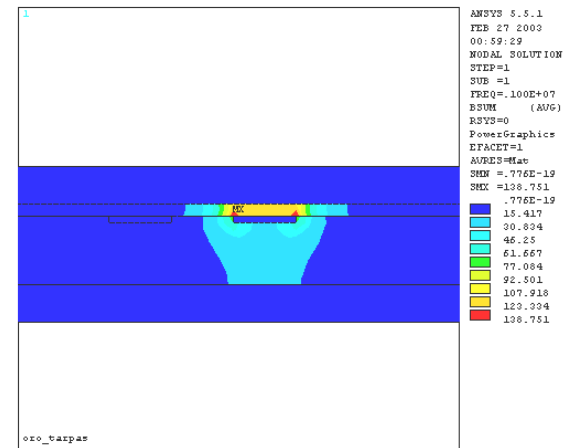

Fig. 7. Summarised magnetic flux density. Excitation frequency 1 MHz, excitation voltage 24 V, distance between electrodes – 10 mm, distance between stator and rotor – 10 mm.

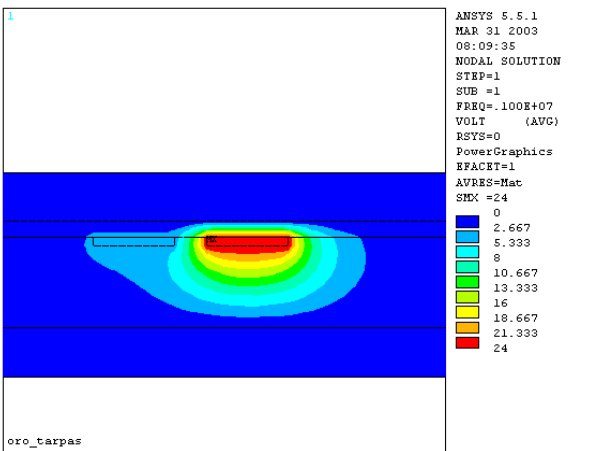

Fig. 5. Voltage values in converter's electrodes and in air gap. Excitation frequency 1 MHz, excitation voltage 24 V, distance between electrodes – 3 mm, distance between stator and rotor – 10 mm.

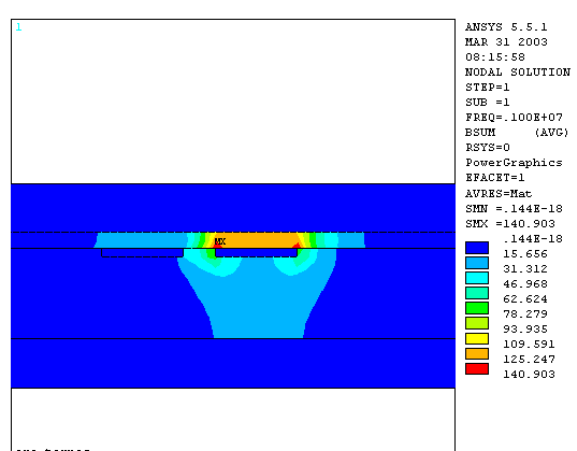

Fig. 8. Summarised magnetic flux density. Excitation frequency 1 MHz, excitation voltage 24 V, distance between electrodes – 3 mm, distance between stator and rotor – 10 mm.

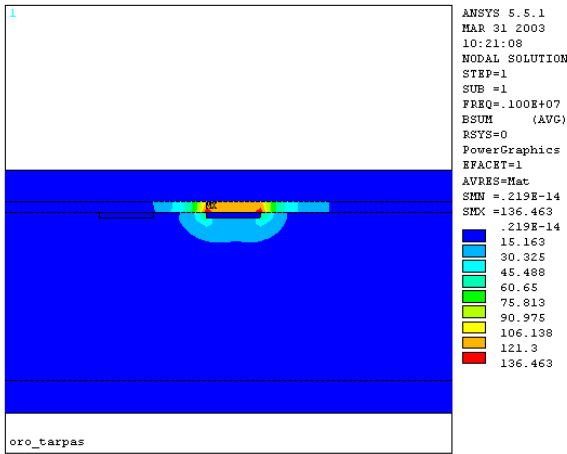

Fig. 9. Summarised magnetic flux density. Excitation frequency 1 MHz, excitation voltage 24 V, distance between electrodes – 10 mm, distance between stator and rotor – 30 mm.

The presented results show that the change in the air gap between the rotor and stator and in the distance between the electrodes makes influence on the summarised magnetic flux density in the gap as well as on the voltage value in the signal receiving electrode. Based on that the converter’s transfer characteristics were calculated in relation to the converter’s feeding and geometrical parameters.

As the research on the converter’s producing possibilities is related to the air gap monitoring system to be implemented in the generator of Kaunas Hydraulic Power Station, certain parameters of the converter model were selected taking into account the design of generator functioning in the mentioned station.

The transfer function of the converter. To determine a transfer function of the converter the following geometrical parameters were selected: the width of electrodes – 10 mm, the distance between electrodes – 10 mm, the height of electrodes – 1.0 mm. The transmitting electrode was excited by 1 MHz 12, 24 and 36 V voltage. Hereunder a relationship between the voltage of the signal receiving electrode and the air gap is presented in Fig. 10.

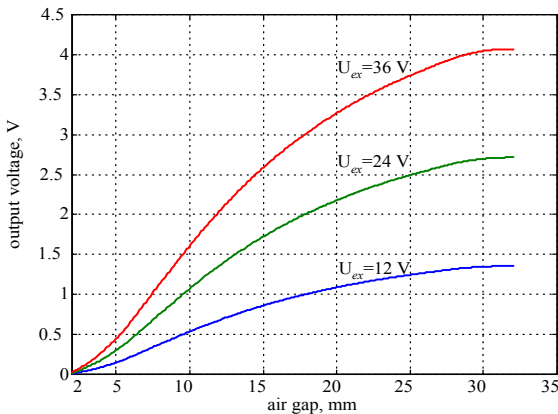

Fig. 10. Relation between output voltage of receiving electrode and air gap between stator’s and rotor’s surfaces with different values of excitation signal

Relationship between the output voltage and the distance between electrodes. To determine the relationship between the converter’s output voltage and the air gap between the electrodes the following geometrical parameters were selected. The width of electrodes – 10 mm. The distance between rotor’s and stator’s surfaces – 10 mm. The height of electrodes – 1.0 mm. The transmitting electrode was excited by 1 MHz 12, 24 and 36 V voltage. Hereunder a relationship between the voltage of signal receiving electrode and the air gap between the electrodes is presented in Fig. 11.

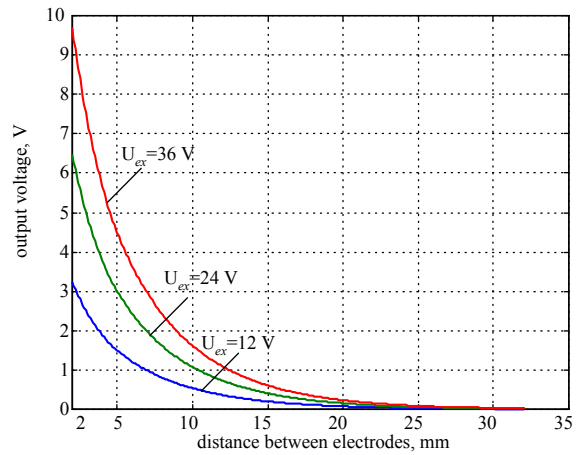

Fig. 11. Relation between the output voltage of receiving electrode and air gap between electrodes with different values of excitation signal

Relationship between the output voltage and the height of electrodes. To determine the relationship between the converter’s output voltage and the height of electrodes the following geometrical parameters were selected: the width of electrodes – 10 mm, the distance between rotor’s and stator’s surfaces – 10 mm, the distance between electrodes – 10 mm. The transmitting electrode was excited by 1 MHz 24 V voltage. Hereunder a relationship between the voltage of signal receiving electrode and the height of electrodes is presented in Fig. 12.

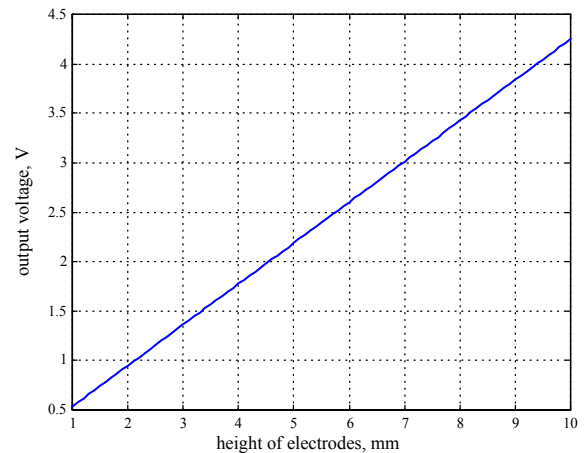

Fig. 12. Relation between output voltage of receiving electrode and height of electrodes

Relationship between the output voltage and the width of electrodes. To determine the relationship between the converter's output voltage and the width of electrodes the following geometrical parameters were selected: the height of electrodes – 1.0 mm, the distance between rotor's and stator's surfaces – 10 mm, the distance between electrodes – 10 mm. The transmitting electrode was excited by 1 MHz 24 V voltage. Hereunder a relationship between the voltage of signal receiving electrode and the width of the electrodes is presented in Fig. 13

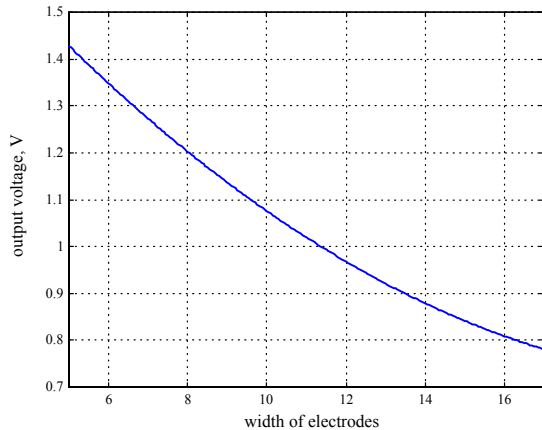

Fig. 13. **Relation between output voltage of receiving electrode and width of electrodes**

The obtained results can be summarised as follows. The converter's transfer function was determined by using a model of a converter designed for measuring the air gap between the stator and rotor in the generator (Fig.10). The determined transfer function shows that with the signal frequency of 1 MHz and excitation voltages of 12, 24, 36 V, the relationship between the air gap and the converter's transfer function is an exponent practically throughout the whole interval from 2 mm to 33 mm. The converter demonstrates the lowest sensitivity when the voltage of excitation signal is 12 V and an opposite sensitivity result is achieved when the excitation voltage is 36 V. The values of excitation signal being different, the most optimal transfer function is reached when the air gap ranges between 5 and 11 mm as the transfer function is almost linear in this interval.

The obtained relationship between the converter's output signal and the electrodes' geometrical dimensions as well as their position in respect of each other shows that the converter's output voltage as an exponent decreases with the increasing distance between the electrodes and with their increasing width (Fig. 11 and 13 respectively). The output signal is directly proportional to the height of electrodes (Fig. 12).

Conclusions

- The results of preliminary model calculations show that the described converter type can be used to measure the air gap between the stator and rotor. This is based on

the obtained transfer function of the converter. The calculations illustrating the relationship between the converter's output signal and the converter's components geometrical parameters as well as their position in respect of each other can be used to achieve an optimal converter design.

- To further develop the converter design analysis it would be advisable to create models which could enable to evaluate:

- The influence of operating environment temperature on the converter transfer function;

- The influence of magnetic field on the converter's measurement characteristics;

- The suitability of substances used for the converter components;

- The influence of vibrations and shocks on the converter functioning.

The converter design analysis must also include a physical experiment to evaluate humidity, dust and oil impact on the measurement characteristics.

References

1. **Gečys S. J.** Uvėličenje načalnogo ekscentrisiteta električeskih mašin v eksperimentálnih uslovijah raboty. (in Russian). Elektrotehnika: Mokslo darbai. Vilnius. 1988. Nr. 15 (24). P. 37-52.
2. **Jonušas R., Jurkauskas A., Volkovas V.** Rotorinių sistemų dinamika ir diagnostika. Kaunas: Technologija. 2001. P. 213-228.
3. **Volkovas V.** Development and application of vibroacoustic diagnostics and condition monitoring methods in Lithuania. Insight. ISSN 1354-2575. BINDT. 2001. Nr. 6 (43). P. 376-380.
4. ANSYS Release 5. Programinio paketo pagalbinės bylos. 1997. P.400.
5. Spravochnik po elektromehaničeskim materialam. (in Russian). Tom II. Maskva: Gosenergoizdat. 1960. P.512.

R. Mikalauskas, V. Volkovas

Rotorinių sistemų oro tarpo modeliavimas ir jo kontrolės galimybės

Reziumė

Dinaminio matavimo priemonės, kurios leidžia akimirksniu gauti informaciją apie oro tarpą tuo metu, kai generatorius veikia, yra labai svarbios įrengimų priežiūrai ir aptarnavimui. Tai leidžia vartotojui tiksliai nustatyti ir kontroliuoti problemą, taigi kartu prailginti generatoriaus eksploatavimo trukmę bei sumažinti proceso metu su remontu susijusius kaštus.

Kadangi kiekvienos elektros mašinos oro tarpo kontrolės sistemos parinkimas arba jos kūrimas yra atskira problema, šiame darbe buvo atlikta keitiklio oro tarpui tarp statoriaus ir rotoriaus matuoti sukūrimo galimybių teorinė analizė. Pirminiame analizės etape buvo sudarytas rotorinės sistemos oro tarpo bei keitiklio matematinis modelis, teoriškai apskaičiuota keitiklio perdavimo funkcija, jo perdavimo charakteristikų priklausomybė nuo elektrodų geometrinių matmenų bei tarpusavio padėties, nustatytas keitiklio jautrumas esant skirtingiems perduodančiojo elektrodo žadinimo signalo dydžiams. Tolesniame etape šių bei papildomų teorinių skaičiavimų pagrindu tikslinga bus tobulinti šį modelį tam, kad būtų galima įvertinti išorinių poveikių įtaką nustatytoms keitiklio charakteristikoms.

Pateikta spaudai 2003 03 09

DOI: 10.5755/j01.u.46.1.8175