

Thickness measurement of individual layers in sandwich structures with unknown ultrasound velocity

M. Vilickas, R. Kažys

Prof. K. Baršauskas Ultrasound institute, Kaunas University of Technology

Studentų st. 50, LT-3031 Kaunas, Lithuania, tel. (+370)656 54323

E-mail: mindaugas_vilickas@centras.lt

Introduction

Recently ultrasound methods are widely used for thickness measurement of various products and constructions. They are especially useful where only one-side access to a particular object (tanks, tubes, wings of planes, fuselages [1]) is feasible.

Nowadays the amount of industrial products with a sandwich structure increases. One of the most developing areas is the production of tubes with the variety in diameters and in thickness of walls manufactured of several different materials. That is why the use of ultrasonic methods for measurement of sandwich structures becomes of a great importance [2]. However, the effective and practical use of ultrasound for such purposes is still problematic. The methods, when there is no necessity to know in advance ultrasound velocity in the material are still not fully investigated.

In order to measure the thickness of a particular object, it is necessary to know an ultrasound velocity in it [3, 4, 5]. In this way, using the impulse method we can measure the time interval between the sent and received impulses and from them to determine thickness of the structure. In most practical cases it takes some time to determine the velocity of ultrasound (which depends on the structure of material, intermixtures, defects, temperatures and etc.) in a particular material and requires additional expenses. The measured velocity will be correct only under the same conditions which were during the time of measuring. Therefore for many practical applications it is important to measure thickness without a priori knowledge of ultrasound velocity in the object under investigation.

There are a few methods suggested in [6, 7], which analyse the thickness measurement of objects without knowledge of ultrasound velocity. Actually they are differential methods, when thickness of object is calculated from two measurements performed at two different points. In paper [6] theoretical description of the method is presented, however there are no experimental or simulation data proving feasibility and illustrating performance of the method proposed. Another version is based on two simultaneously operating channels: in one channel an ultrasonic wave propagates perpendicularly to the surface of the multi-layered object, in the second channel the wave is sent at the angle less than 90° [7]. In this case propagation paths in the channels are different, what enables to determine thickness of individual layers

without a priori knowledge of ultrasound velocities. While radiating at the 90° angle to the object, it's quite difficult to avoid distortions of the received signals due to the interference of sent and received impulses. That should lead to additional measurement errors.

Descriptions of the methods, presented in [6], and [7] are rather brief, experimental verification or analysis of measurement errors are missing. The objective of this paper is the analysis of the method for thickness measurement, which does not require a priori knowledge of ultrasound velocity in the material under investigation.

Principle of measurement

In the method, suggested in [6], an ultrasonic wave is transmitted to an object by the transmitter T at two different angles α_1 and α_2 (Fig.1). After reflection from the bottom surface of the object measured, it is picked-up by the receiver R.

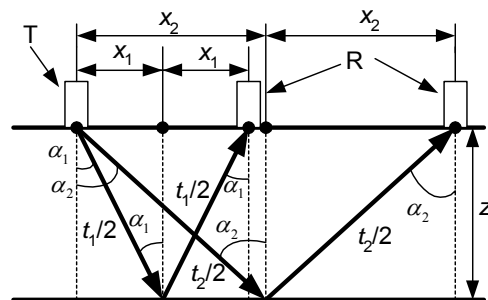

Fig. 1. Measurement of a single-layer structure: T - transmitter; R - receiver; x_1 , x_2 - half of a distance between transducers at different angles α_1 and α_2 of the incident wave; z - thickness of the object measured; t_1 , t_2 - the time of flight of the wave in the object

The transducer R will receive the wave from the transmitter at distances $2x_1$ or $2x_2$, depending on the angle, at which the transmitter has sent it. According to Fig. 1, the thickness z of the object and the velocity c of the wave in that object are interrelated [6]:

$$\begin{cases} c^2 \times \frac{t_1^2}{4} = z^2 + x_1^2 \\ c^2 \times \frac{t_2^2}{4} = z^2 + x_2^2 \end{cases} \quad (1)$$

After solving Eq.1, we obtain the following values for the ultrasound velocity and the thickness of the object [6]:

$$c = \frac{2\sqrt{x_2^2 - x_1^2}}{\sqrt{t_2^2 - t_1^2}}, \quad (2)$$

$$z = \sqrt{\frac{x_2^2 \times t_1^2 - x_1^2 \times t_2^2}{t_2^2 - t_1^2}}. \quad (3)$$

The distance between the transmitter and the receiver and the time t_1 and t_2 during which the wave radiates between transducers are directly measured. In order to calculate the ultrasound velocity according to Eq.2 and 3 in the object and its thickness, every time when transmitting the wave to the object, two measurements are made at different angles. It is assumed, that the velocity of the wave in the object is the same in spite of the angle at which it is radiated.

The model of sandwich structure

The thickness measurement mentioned above allows to measure the thickness of individual layers in the object consisting of several layers (Fig. 2.).

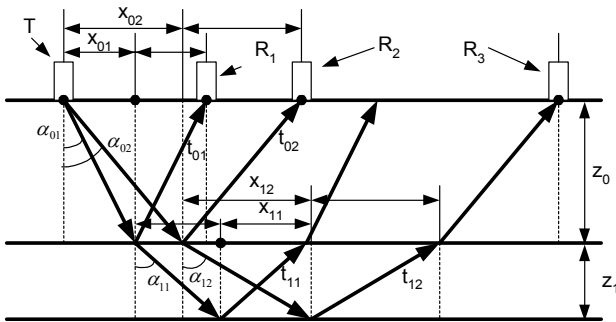

Fig. 2. The measurement of thickness of several layers: T-transmitter, R₁, R₂, R₃ - receivers; x₀₁, x₀₂, x₁₁, x₁₂ - half of a distance between transducers at different angles α₀₁, α₀₂, α₁₁, α₁₂ of the incident wave; z₀, z₁ - thicknesses of the layers; t₀₁, t₀₂, t₁₁, t₁₂ - the time of flight of the wave in the object

A measurement system can be either single-channel or multi-channel. In the case of the multi-channel system several receivers (R₁, R₂, R₃) are set at the certain distances from a transmitter in order to receive the impulses reflected from the boundaries of the layers (Fig. 2). In the case of the single-channel system (this one was used for implementation of the experiment of this work), the position of the receiver R with respect to the transmitter is changed while moving it to one or another direction depending on the layer, from which the impulse is received. The distances between the transmitter and the receiver (receivers), knowing approximately the thickness of layers of the object under investigation, are estimated in two ways: either they are calculated or they are chosen according to the maximum value of amplitude of the impulse received.

Theoretically it is considered that an ultrasonic wave propagates, is refracted and reflected according to the laws of geometrical optics. Making an assumption, that the

transmitted wave is a cone of rays, and multiple reflections either do not return back to the receiver, or they are attenuated in a such degrees that do not have any influence on the signal received, the length of a propagation path of any ray from the transmitter to the receiver (Fig. 2) in the first layer is given by:

$$l_{01} = \frac{2x_{01}}{\sin \alpha_{01}}, \quad (4)$$

Correspondingly, the time of flight is:

$$t_{01} = \frac{2x_{01}}{c_{01} \sin \alpha_{01}}. \quad (5)$$

The propagation path of impulses received from other layers is:

$$l_n = \frac{2x_{01}}{\sin \alpha_{01}} + \dots + \frac{2x_{n-1}}{\sin \alpha_{n-1}} + \frac{2x_n}{\sin \alpha_n}, \quad (6)$$

The time of flight is:

$$t_n = \frac{2x_{01}}{c_{01} \sin \alpha_{01}} + \dots + \frac{2x_{n-1}}{c_{n-1} \sin \alpha_{n-1}} + \frac{2x_n}{c_n \sin \alpha_n}. \quad (7)$$

Here l_{01} and l_n are the propagation distances of the received impulses from the first and n layers; t_{01} and t_n - delay time, after which the receiver gets the reflected impulses from the first and n layers; c_{01} , c_{n-1} , c_n - the velocity of ultrasound in particular layers of the object; α_{01} , α_{n-1} , α_n - the angles at which impulses fall into a layer. The angle of incidence is chosen in the first layer, in other ones the incident angles are calculated as follows:

$$\alpha_2 = \arcsin\left(\frac{c_2 \sin \alpha_1}{c_1}\right), \quad (8)$$

where α_1 is the known incident wave angle of the first layer, α_2 is not known incident wave angle in the next layer, c_1 and c_2 are the velocities of the longitudinal ultrasound waves in layers. The longitudinal waves can propagate in the liquid; and in solid may propagate both: the longitudinal waves as well as shear ones. Which kind of wave - longitudinal or shear propagates in an object depends on the angle of incidence. At the first critical angle (α_{cr} - the critical angle, c_1 and c_2 - the velocities of longitudinal ultrasound waves in materials), which represented by Snell's law:

$$\sin \alpha_{kr} = \frac{c_1}{c_2}, \quad (9)$$

the longitudinal wave propagates on the border of two layers, and the receiver can not pick up it. When the transducer radiates the wave at an angle, which is less than the first critical one, the longitudinal waves will propagate in the layers; if the angle is bigger than the first critical one, only the shear waves propagate in the layers. The amplitude of shear waves is several times less than the amplitude of longitudinal ones. Every layer has its own critical angle and the wave has to fall to the object at the angle less or bigger than α_{cr} .

The measurement method under investigation can be contact and contactless type. In the second case there is a layer of liquid between the transducers, which can be treated as an additional layer of the object under investigation, which contact both - the object under

investigation and the transducers (Fig. 3). A spatial position of transducers can be adjusted in a liquid and the wave can be radiated in to the object at different angles using the same transducers. In the case of the direct contact the transducers, radiating impulses at different angles, are required.

In reality the ultrasonic wave radiated by the active surface of the transducer (Fig. 3.) propagates like a beam diameter of which matches the diameter of the transducer at the near field zone and expands in the far-field zone. While over passing the borders of layers, the part of wave is reflected; the other part passes through. Both waves propagate in the material and change their direction because of non-uniformities of structures. The inaccurate measurement of the orientation angles of transmitting and receiving transducers, reception of impulse at several different spatial points, measurement errors of distances

between transducers and inaccurate determination of their positions, external noise having an influence on a whole measurement system, the influence of temperature, etc. also influence the precision of measurements.

In the proposed mode we do not take into account the differences in propagation distances, which wave overcomes from different places of transducers (look to Fig. 3, the dotted line in the far field zone shows the differences in propagation distances of rays), because it is assumed, that the wave radiated from the zone of the transmitter T, which is closer to the surface of the object under investigation, reaches the zone of the receiver R, which is further from the surface of the object. For this reason, the differences in propagation distances mentioned above can be eliminated.

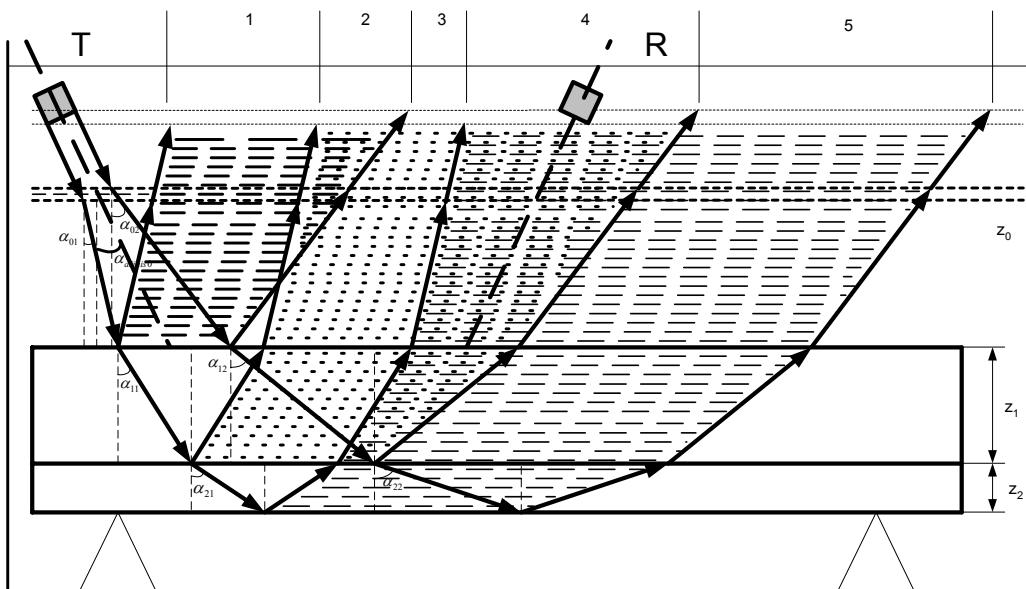

Fig.3. Propagation of ultrasonic waves in a multi-layered structure: 1 - zone, where the wave reflected by the front surface of the first layer of the object is received; 2 - zone, where the wave reflected by the second surface of the first layer of the object is overlapping with the wave from the first zone; 3 - wave reflected only by the second surface of the first layer of the object; 4 - mixture of the waves reflected by the first and the second layers; 5 - wave reflected from the second layer of the object under investigation

The thickness of the first layer z_0 , e.g., the thickness of water layer which is in between the object under investigation and the radiation surface the transmitter, is chosen after the beginning of a far field zone of transducers which are used for the experiments. The spreading ultrasonic beam angle in the far field zone (Fig. 3) and the beginning of that zone from the surface of the transducer depend on the diameter of the transducer D and the radiating frequency f and are evaluated as follows [2], [8]:

$$r_0 = \frac{D^2}{4\lambda},$$

where

$$\lambda = \frac{c}{f}, \tag{10}$$

$$\theta_0 = 2 \arcsin\left(1.22 \frac{\lambda}{D}\right). \tag{11}$$

Here D is the diameter of the radiating surface of the transducer, f is the frequency of radiated wave, r_0 is the near field zone. The transducers used in this work have a very small angle θ_0 , and for this reason it is assumed, that the front of the wave in the far field zone is plane. Otherwise, we need to correct the Eq. 4, -7 evaluating the propagation distance of the wave in the near and far field zones.

Measurement uncertainties of method

The sources of uncertainties of the method suggested are determination of the distance between the transducers x and time t of the impulse propagation. The total uncertainty, that is, the uncertainties of the ultrasound

velocity c (Eq. 2) in the object and its thickness z (Eq. 3), are:

$$u_{\sum c} = \pm \sqrt{(u_{x1}K_{cx1})^2 + (u_{x2}K_{cx2})^2 + (u_{t1}K_{ct1})^2 + (u_{t2}K_{ct2})^2}, \quad (12)$$

$$u_{\sum z} = \pm \sqrt{(u_{x1}K_{zx1})^2 + (u_{x2}K_{zx2})^2 + (u_{t1}K_{zt1})^2 + (u_{t2}K_{zt2})^2}, \quad (13)$$

where u are the uncertainties of input quantities (the distances between the transducers x and the time t of wave propagation), K are the sensitivity coefficients, which show what influence has one or another input variable on the total uncertainty of the result. They are calculated searching for the partial derivatives of Eq. 2 and 3 according to the particular input variable, which influence is evaluated [9, 10, 11]. The coefficients of sensitivity for the determination of the total uncertainty of the ultrasound velocity are given by:

$$K_{cx1} = \frac{-2\bar{x}_1}{\sqrt{\bar{t}_2^2 - \bar{t}_1^2} \sqrt{\bar{x}_2^2 - \bar{x}_1^2}}, \quad (14)$$

$$K_{cx2} = \frac{2\bar{x}_2}{\sqrt{\bar{t}_2^2 - \bar{t}_1^2} \sqrt{\bar{x}_2^2 - \bar{x}_1^2}}, \quad (15)$$

$$K_{ct1} = \frac{2\bar{t}_1 \sqrt{\bar{x}_2^2 - \bar{x}_1^2}}{\sqrt{(\bar{t}_2^2 - \bar{t}_1^2)^3}}, \quad (16)$$

$$K_{ct2} = \frac{-2\bar{t}_2 \sqrt{\bar{x}_2^2 - \bar{x}_1^2}}{\sqrt{(\bar{t}_2^2 - \bar{t}_1^2)^3}}. \quad (17)$$

The sensitivity coefficients for the determination of the total uncertainty of thickness of any layer are given by:

$$K_{zx1} = \frac{-\bar{x}_1 \bar{t}_2^2}{(\bar{t}_2^2 - \bar{t}_1^2) \sqrt{\frac{\bar{t}_1^2 \bar{x}_2^2 - \bar{t}_2^2 \bar{x}_1^2}{\bar{t}_2^2 - \bar{t}_1^2}}}, \quad (18)$$

$$K_{zx2} = \frac{\bar{x}_2 \bar{t}_1^2}{(\bar{t}_2^2 - \bar{t}_1^2) \sqrt{\frac{\bar{t}_1^2 \bar{x}_2^2 - \bar{t}_2^2 \bar{x}_1^2}{\bar{t}_2^2 - \bar{t}_1^2}}}, \quad (19)$$

$$K_{zt1} = \frac{\frac{2\bar{t}_1 \bar{x}_2^2}{\bar{t}_2^2 - \bar{t}_1^2} + \frac{2\bar{t}_1 (\bar{t}_1^2 \bar{x}_2^2 - \bar{t}_2^2 \bar{x}_1^2)}{(\bar{t}_2^2 - \bar{t}_1^2)^2}}{2 \sqrt{\frac{\bar{t}_1^2 \bar{x}_2^2 - \bar{t}_2^2 \bar{x}_1^2}{\bar{t}_2^2 - \bar{t}_1^2}}}, \quad (20)$$

$$K_{zt2} = \frac{\frac{-2\bar{t}_2 \bar{x}_1^2}{\bar{t}_2^2 - \bar{t}_1^2} - \frac{2\bar{t}_2 (\bar{t}_1^2 \bar{x}_2^2 - \bar{t}_2^2 \bar{x}_1^2)}{(\bar{t}_2^2 - \bar{t}_1^2)^2}}{2 \sqrt{\frac{\bar{t}_1^2 \bar{x}_2^2 - \bar{t}_2^2 \bar{x}_1^2}{\bar{t}_2^2 - \bar{t}_1^2}}}. \quad (21)$$

Statistical modeling

The statistical modeling was implemented before the experiment in order to evaluate expected uncertainties of measurements. For the modeling two objects were selected: the flat plexiglas sample and the polyethylene tube consisting of two-layers. The uncertainties of time of flight in the layers of the objects and the distances between the transducers were simulated using the functions of RAND and RANDN of "MATLAB". The sensitivity coefficients were also calculated, and they show what influence the sources of uncertainties of the method have on the values of the calculated uncertainties (Tables 1-3).

Table 1. Values of the sensitivity coefficients K for the water layer between transducers and object under investigation

Sensitivity coefficients	Value
K_{cx01}	$-9.9 \cdot 10^3$
K_{cx02}	$2.2 \cdot 10^4$
K_{ct01}	$2.9 \cdot 10^7$
K_{ct02}	$-3.2 \cdot 10^7$
K_{zx01}	-1.3
K_{zx02}	2.4
K_{zt01}	$3.9 \cdot 10^3$
K_{zt02}	$-3.5 \cdot 10^3$

Table 2. Values of the sensitivity coefficients K for the first layer of the polyethylene tube

Sensitivity coefficients	Value
K_{cx11}	$-9.5 \cdot 10^4$
K_{cx12}	$5.1 \cdot 10^5$
K_{ct11}	$4.9 \cdot 10^8$
K_{ct12}	$-6.3 \cdot 10^8$
K_{zx11}	-0.4
K_{zx12}	1.3
K_{zt11}	$2 \cdot 10^3$
K_{zt12}	$-1.6 \cdot 10^3$

During modeling it was assumed that intervals in which variables x and t are dispersed, are as follows:

- The uncertainty of distance measurement between transducers x is ± 1 mm.
- The uncertainty of time measurements is ± 10 ns.

Table 3. Values of the sensitivity coefficients K for the second layer of the polyethylene tube

Sensitivity coefficients	Value
K_{cx21}	$-3.1 \cdot 10^5$
K_{cx22}	$1.1 \cdot 10^6$
K_{cr21}	$5.3 \cdot 10^8$
K_{cr22}	$-8.3 \cdot 10^8$
K_{cx21}	-0.6
K_{cx22}	0.9
K_{cr21}	$1.1 \cdot 10^3$
K_{cr22}	-703

The modeling results are presented in Table 4 and 5:

Table 4. Modeling results for plexiglas

Dimension	c_0 , m/s	c_1 , m/s	z_0 , mm	z_1 , mm
Value*	1478	2778	149.2	21
Uncertainty* u	± 1.4	± 3.5	± 0.2	± 0.05
Value**	1471	2745	148.6	21
Uncertainty** u	± 5.3	± 14	± 0.6	± 0.2

* - Uniform probability density distribution of values.
 ** - Gaussian probability density distribution of values.

Table 5. Modeling results for two-layer polyethylene tube

Dimension	c_0 , m/s	c_1 , m/s	c_2 , m/s	z_0 , mm	z_1 , mm	z_2 , mm
Value *	1479	1929	2362	149.3	4.5	1.7
Uncertainty* u	± 1.5	± 32	± 68	± 0.2	± 0.1	± 0.1
Value **	1475	1705	1723	149.2	4.1	1.4
Uncertainty** u	± 5.0	± 107	± 195	± 0.6	± 0.3	± 0.2

* - Uniform probability density distribution of values.
 ** - Gaussian probability density distribution of values.

The modeling results of uncertainties show that the method suggested is suitable for many practical applications.

Analysis of waveforms of ultrasonic impulses

The impulse received from the object under investigation is attenuated and its shape is distorted. Therefore, in order to estimate accuracy of measurements it is necessary to know how much it will be attenuated and what kind of shape it will have. The sent ultrasonic impulse $S(t)$ may be described by [12]:

$$S(t) = \exp\left(\left(\frac{2f\sqrt{-\log 0.1}}{p}\left(t - \frac{2p}{3f}\right)\right)\right) \cdot \sin\left(2\pi f t\right) \cdot \exp\left(\left(\frac{2f\sqrt{-\log 0.1}}{p}\left(t - \frac{2p}{3f}\right)\right)\right) \cdot \sin(2\pi f t) \quad (22)$$

where: f is the frequency of the impulse; p is the number of periods; t is the time. If the impulse was not attenuated, it would be enough to estimate the delay time t_n (Eq.7):

$$S_v(t) = S(t - t_n). \quad (23)$$

The attenuation of the received impulse can be estimated in two ways:

- Making an assumption, that all components of different frequencies in the measured object are attenuated similar, therefore only the amplitude of received impulse reduces but the shape of the impulse remains the same.
- Making an assumption, that components of different frequencies are attenuated differently, therefore not only the amplitude of the impulse received declines, but its shape is deformed.

With a reference to the first assumption the attenuation of an impulse is estimated as follows:

$$S_x(t) = S_0 \exp(-\alpha_x l_x), \quad (24)$$

where S_0 is the amplitude of the impulse, α_x is the attenuation coefficient in the layer, l_x is the propagation distance of the impulse in the layer, $S_x(t)$ is the impulse received.

In the second case the attenuation of the received impulse is estimated in the following way:

$$S_{IN}(f) * K(f) = S_{OUT}(f). \quad (25)$$

FFT [13] is applied to the radiated impulse $S(t)$ and then the spectrum of the received impulse according to Eq.25 is found. IFFT is applied to this spectrum, and the received impulse $S_x(t)$ is found.

The transfer function $K(f)$ is calculated according to the expressions:

$$K(f) = \exp(-\alpha_x(f) l_x), \quad (26)$$

$$\alpha_x(f) = k f^n, n = 1.5. \quad (27)$$

where α_x is the attenuation coefficient in the layer depending on the frequency f ; l_x is the propagation distance of the impulse in the layer; k is the coefficient, $n=1.5$ is the coefficient depending on a material type.

The simulation results in the case of two layer plastic material immersed into water are presented in Fig. 4. In each figure there are shown simulation results at two different angles of incidence of an ultrasonic wave: on the left side three impulses are obtained at the receiver at the angle of incidence $\alpha=15^\circ$, on the right side at $\alpha=30^\circ$.

Experimental system

The block diagram of the system used for experiments is presented in Fig. 5.

The dimensions of the tank where the experiment was implemented, are 1230x735x340mm. It is possible to scan ultrasonic transducers inside the water tank in the zone along three perpendicular directions - X, Y and Z. The range of scanning along X coordinate is from 0 to 1000mm, along Y coordinate from 0 to 600mm. Both of them have the same scanning step, which is 9 μ m, together with absolute repeatability is $\pm 50\mu$ m. Scanning along the Z coordinate is in the range [0, 360 mm], step is 1 μ m, and

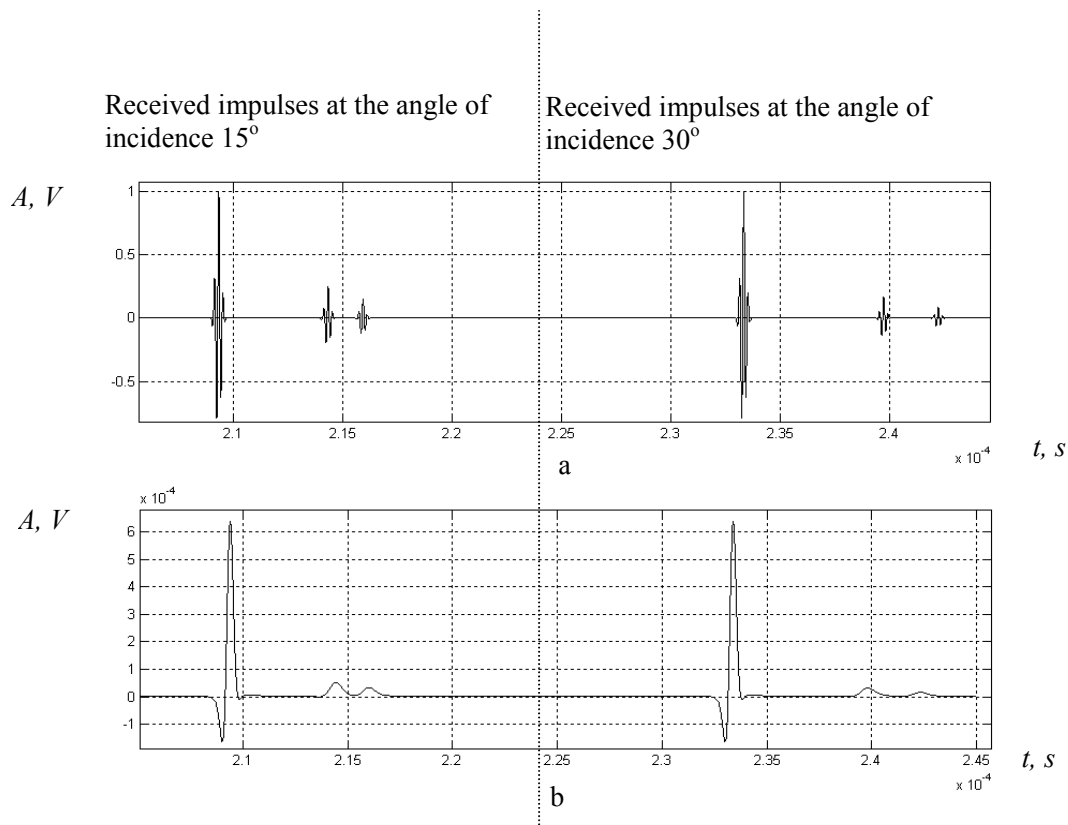

Fig 4. Modeling of ultrasound impulses received from a multi-layered structure of two different angles of incidence: a – only reduction of amplitude is taken, b – frequency dependent attenuation $\alpha(f)$ is taken into account ($n=1.5$)

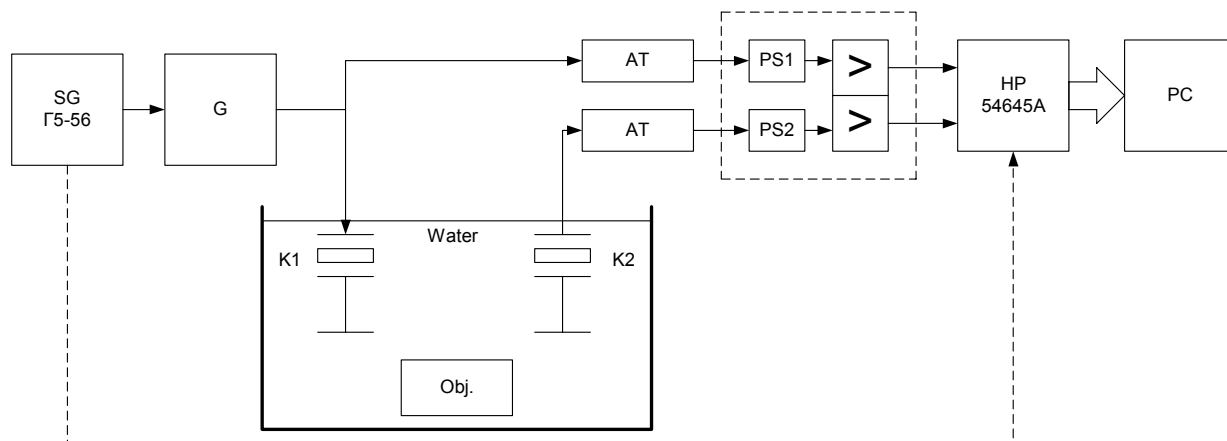

Fig. 5. Structure of the measurement system: SG - synchrogenerator; G - generator; K1, K2 – ultrasonic transducers (the diameter of the active surface 12mm, the spreading angle in a far field zone is 3°, the frequency is 5MHz); AT - attenuator; PS1, PS2 - preamplifiers; HP54645A – digital oscilloscope; PC - computer

repeatability is $\pm 10\mu\text{m}$. The samples were fixed to the angular scanner, which enabled to change spatial orientation of the sample from 0° to 360° with the step 0.015° and repeatability better than $\pm 0.013^\circ$.

The measurement is implemented with the digital 8bits HP54645A oscilloscope, bandwidth of which is 100MHz and the sampling frequency is 200Msamples/s

The ultrasound transducer T operates in a transmitting mode. It is excited by the generator G, the impulse is

radiated into the object, the transducer R receives the reflected impulse from the surface of the object and through the attenuator AT and through the amplifier transfers it to the digital oscilloscope. The oscilloscope is connected to a personal computer, which is able to store ultrasonic wave forms. The plane in which the transducers are placed is parallel to the surface of the object. The distance z_0 from the active surfaces of the transducers to the object under investigation was 150 mm. The

inclination angles of the transducers α_{01} and α_{02} were chosen 15° and 30° respectively. This system enables to measure the impulse time of flight of the received impulses and the distances between the transducers. The collected data are used for calculation of the thickness of individual layers in the sandwich object and the ultrasound velocities. The measured time of flight of impulse in the objects is the integer t value, which is the closest to the maximum value of the impulse in the time domain.

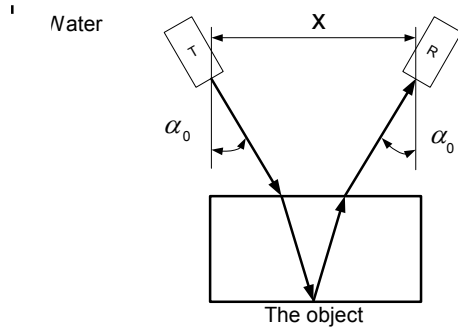

Fig. 6. Measurement principle

Results

In order to demonstrate feasibility to measure thickness of individual layers and ultrasound velocity the experiments were carried out using the described above measurement system. The disc of plexiglas and the two-layer polyethylene tube were the objects chosen for the experiments. The first one was convenient for the experiment as it had a single-layer and it was rather thick, so, it was possible to identify the exact time of the impulses reflected from its surfaces. This experiment enables us verify if it is practically possible to implement the described method and to check how the results of modeling satisfy the results of the experiment. The a priori known velocity of the longitudinal ultrasound wave in the plexiglas sample is 2353 ± 37 m/s; its thickness is 20 ± 0.1 mm. Correspondingly, the thickness of layers of the polyethylene tube are 4.7 ± 0.3 mm and 1.8 ± 0.2 mm; the velocities of longitudinal ultrasound waves in layers respectively are 2000 ± 95 m/s and 2370 ± 122 m/s.

The thickness of the objects and the velocity of ultrasound in them were calculated using the experimental results (Tables 6–9). The measured thickness of plexiglas is 17.8 ± 0.2 mm; the measured velocity of ultrasound in it is 2010 ± 14 m/s. The thickness of the external layer of the polyethylene tube is 5.1 ± 0.3 mm; the velocity of ultrasound in it is 2256 ± 107 m/s; the thickness of the middle layer is 2.4 ± 0.2 mm; and it was not possible to measure reliably the ultrasound velocity in it.

Table 6. Measurement results of plexiglas plate at the angle of incidence 15°

Measurement No.	Delay time of impulse $\Delta t, \mu s$	Distance between transducers $\Delta x, mm$
1	210	84
2	229	98

Table 7. Measurement results of plexiglas plate at the angle of incidence 30°

Measurement No.	Delay time of impulse $\Delta t, \mu s$	Distance between transducers $\Delta x, mm$
1	234	160
2	267	216

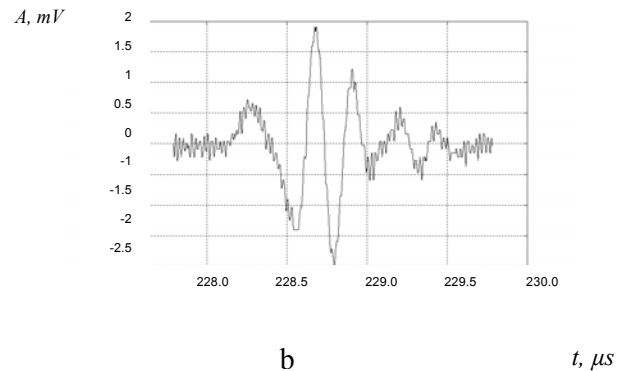
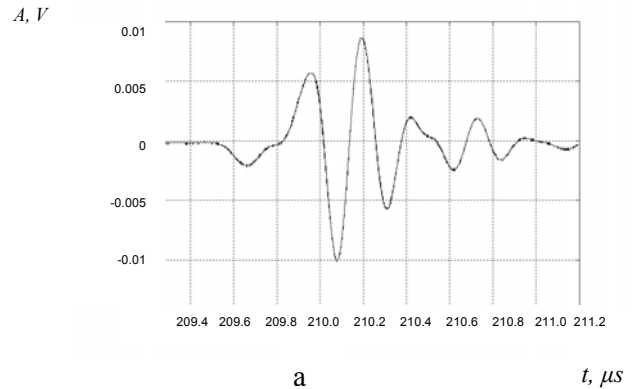

Fig. 7. Reflected ultrasonic signals at the angle of incidence 15° : a - the signal reflected by the front surface of a plexiglas sample immersed in water; b - the signal reflected by the back surface of a plexiglas sample immersed in water

Table 8. Results of measurements when wave was radiated to the polyethylene tube at 15° angle

Measurement No.	Delay time of impulse $\Delta t, \mu s$	Distance between transducers $\Delta x, mm$
1	217	83
2	222	88
3	223	89

Table 9. Results of measurements when wave was radiated to the polyethylene tube at 30° angle

Measurement No.	Delay time of impulse $\Delta t, \mu s$	Distance between transducers $\Delta x, mm$
1	249.5	180
2	255.5	189
3	258	195

There were also measurements made at the angle of incidence, at which shear waves were propagating in its layers. The amplitude of these waves was several times lower than of longitudinal ones, and due to a noise it was not possible to identify where the informative impulse is in the time domain.

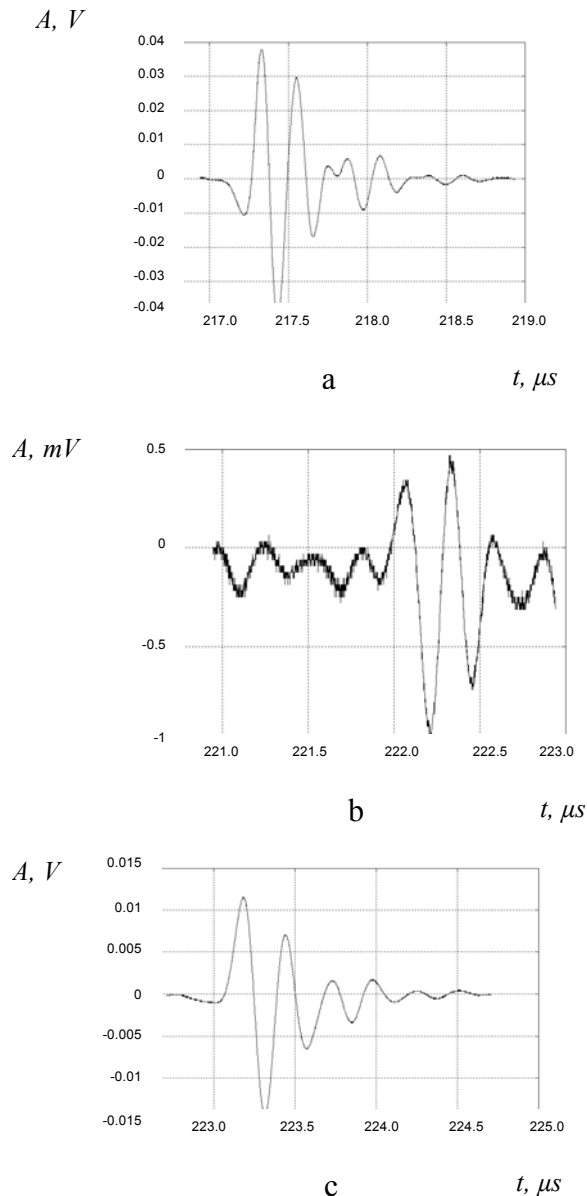

Fig. 8. Reflected ultrasonic signals at the angle of incidence 15°: a - the signal reflected by the front surface of the outer layer of the polyethylene tube immersed in water; b - the signal reflected by the back surface of the outer layer of the polyethylene tube immersed in water; c - the signal reflected by the back surface of the inner layer of the polyethylene tube immersed in water

Conclusions

Ultrasonic method for simultaneous measurement of individual layer thickness and ultrasound velocities in

multi-layered sandwich structures was proposed and investigated.

The thicknesses of individual layers of sandwich structures and the ultrasound velocity in them were determined without knowing in advance the ultrasound velocity in the material. The measurements were performed using longitudinal ultrasonic waves. The measured parameters, e.g. layer thickness of the objects and ultrasound velocity are quite close to the modeling results.

The obtained modeling results of plexiglas sample and two-layer tube indicate that less accurate results were obtained in the case of thin (in the millimeter range) layers; when the thickness of layers was more than 10mm, the precision of measurements obtained is suitable for practical applications.

Experiments have shown that application of shear waves due to a very low amplitude of the reflected signal is not prospective for such measurements.

References

1. **US patent** 5608165 Ultrasonic thickness gauge for multilayer plastic fuel tanks// <http://www.ndt.net/news/patents/5608165/5608165.htm>. 1997 03 04.
2. **Lindstedt G.** Borrowing the Bat's Ear for Automation – Ultrasonic Measurements in an Industrial Environment. Department of Industrial Electrical Engineering and Automation (IEA) Lund Institute of Technology (LTH). 1996. P.122p.
3. **Diederichs R.** Automated in-mould ultrasonic wall-thickness measurement(IMM). // <http://www.ndt.net/article/imm/imm-e.htm>. 2000.10.13, 6p.
4. **Kimura T., Kameyama S., Misu K., Wakada S., Tanaka H.** Analysis of echoes in ultrasonic testing for round bar using angle beam immersion technique. Mitsubishi Electric Corporation. Information Technology R&D Center. Electro-Optics & Ultrasonics Dept., 5-1-1, Ofuna, Kamakura, Kanagawa, 247-8501, Japan.
5. **He P.** Simultaneous measurement of sound velocity and wall thickness of a tube. Ultrasonics. 2001. Vol.39. P. 407-411.
6. **Siegel M.** Measurement Issues in Quantitative Ultrasonic Imaging. IEEE Transactions on instrumentation and measurement. 1998. Vol.47. No.6.
7. **Greco de Sousa A.V., Machado J.C., Pereira W.C.A.** Ultrasonic characterization of stratified media with independent measurement of wave velocity and thickness. Brazilian Navy Institute of research. In Proceedings of the 2002 IEEE International Ultrasonic Symposium, Munich, Germany, 8-11 October 2002/<http://www.ieee-uffc.org/archive/ul/2002.htm>
8. **Домаркас В.И., Кажис Р.И.** Контрольно-измерительные пьезоэлектрические преобразователи. Вильнюс: Минтис. 1974. С. 258.
9. **EA-4/02** Expression of the Uncertainty of Measurement in Calibration. Publication Reference/<http://www.a2la2.net/documents/webindex.cfm>, 1999.
10. **Adams T.M.** A2LA Guide for the Estimation of the Uncertainty of Dimensional Calibration and Testing Results. www.a2la2.net/documents/webindex.cfm, 2002.
11. **Adams T.M.** A2LA Guide for the Estimation of Measurement Uncertainty In Testing. www.a2la2.net/documents/webindex.cfm, 2002.
12. **Akelaitis R.** Binauralinio metodo, skirto objektų padėties matavimui, tyrimas. Magistro darbas, KTU Telekomunikacijų ir elektronikos fakultetas, Teorinės radiotechnikos katedra, Kaunas, 2000.
13. **Richard Ed., Dorf. C.** The Electrical Engineering Handbook, Section II, Signal Processing. Boca Raton: CRC Press LLC, 2000.

M. Vilkickas, R. Kažys

**Daugiasluoksnių struktūrų atskirų sluoksnių storių matavimas
nežinant ultragarso sklaidimo greičio**

Reziumė

Ištirtas keliasluoksnių struktūrų atskirų sluoksnių storių ultragarsinis matavimo metodas, kurį taikant nereikia žinoti ultragarso sklaidimo medžiagoje greičio. Buvo sudarytas tiriamosios keliasluoksnių struktūros modelis ir juo remiantis tirtas šis matavimo metodas. Taip pat pasiūlytas algoritmas objekto sluoksnių storiams apskaičiuoti, įvertinant atstumo tarp keitiklių ir signalo sklaidimo laikų sluoksniuose nustatymo neapibrėžtis.

Atliktas statistinis modeliavimas siekiant teoriškai patikrinti, kokių praktinių rezultatų galima tikėtis eksperimento metu.

Remiantis tuo, kad išilginės ultragarso bangos slopinamos mažiau nei skersinės, su pirmosiomis atlikti eksperimentiniai matavimai. Išmatuoti parametrai – signalo sklaidimo laikas t ir atstumas tarp keitiklių x gerai atitinka teoriškai apskaičiuotus, o iš jų apskaičiuoti rezultatai (objektų sluoksnių storiai z) pakankamai gerai atitinka modeliavimo metu gautus rezultatus bei patvirtina, kad galima rasti daugiasluoksnių struktūros sluoksnių storius ir ultragarso sklaidimo juose greičius iš anksto nežinant, koks yra ultragarso sklaidimo medžiagoje greitis. Eksperimento metu sluoksniuose sklindant skersinėms bangoms dėl mažos jų amplitudės iš priimto signalo nepavyko patikimai nustatyti, kurioje vietoje matomas informacinis signalas. Iš to galima spręsti, jog praktiškai tikslinga parinkti tokius signalų spinduliavimo į objektą kampus, kad sluoksniuose sklįstų išilginės bangos, kurias dėl didesnės amplitudės lengviau registruoti.

Pateikta spaudai 2003 06 26

DOI: 10.5755/j01.u.49.4.8257