

# Application of CLEAN algorithm in ultrasonic NDT for distinct detection of close peaks in a pulse compression system

Mahmud Khan Mohammad<sup>1</sup>, Ryoji Ohba<sup>2</sup>

*Affiliation:*

*Graduate School of Engineering, Hokkaido University, Japan*

*1 Corresponding author: Kanagaw ken, Kawasaki City, Saiwai-ku, Kawara cho danchi -1-8-116, Japan*

*Phone/Fax: +81-44-511-6415 E-mail: [mahmud@e-globaledge.com](mailto:mahmud@e-globaledge.com)*

*2Division of Applied Physics, Graduate School of Engineering,*

*Hokkaido University, Sapporo 060-8628, Japan.*

*Phone: +81-11-706-6626 Fax: +81-11-706-7883 E-mail: [rohba@eng.hokudai.ac.jp](mailto:rohba@eng.hokudai.ac.jp)*

## Introduction

Now the pulse compression systems have been widely used in the field of NDT for detecting material defects. In ultrasonic pulse compression systems, usually the manipulation of the received signal gives the indication of material defects/faults in the form of sharp peak corresponding to each reflection. For defects/faults, a fair distant away from each other, the cross-correlation peaks can be displayed quite distinctly. But it is often a considerable problem to detect the peaks distinctly for closely spaced faults. The problem is severe when one peak is within the range of main peak or even within the side lobe area of its neighboring peak. In this paper, a new approach of detecting the close peaks as well as obtaining distinct peaks with zero side lobes is proposed. The method utilizes CLEAN algorithm [1-3], which is familiar in the field of radio astronomy. It is quite efficient and useful in astronomical image processing. A survey on recent research utilizing this algorithm shows that its potential area of application is widening [4-6]. How to apply it in ultrasonic NDT is the main topic of this paper. In our previous work, we developed some noise reduction techniques to detect peaks corresponding to small targets in air [7] and then to detect holes in metal medium [8] with a considerable distance between one and the other. Here we will use all those techniques as a preprocessing step before application of the CLEAN algorithm. This paper focuses on the discrete detection of multiple close holes in a metal plate.

## Principles and system description

In order to apply the CLEAN algorithm in ultrasonic NDT, the process of cross-correlation between transmitted signal and received signal has been adopted. For this purpose, a rectangular aluminum plate is considered on which a transmitter and a receiver are set at predetermined locations. A M-sequence modulated ultrasonic pulse wave is used as the transmitting signal and reflections from targets are received by the receiver at a suitable point. Cross-correlating the demodulated received signal with the original M-sequence, the reflections corresponding to the

targets can be seen as sharp peaks. By processing the received data, locations of the targets can be determined from travel times of the signal in the probed medium. The M-sequence can be considered as a pseudo white-noise input of the system; hence the cross-correlation function (CCF) of the input noise and the system output will be proportional to the system impulse response. The detection is accomplished by deriving the impulse response of the system from the CCF of the original M-sequence and of the received sequence. The cross-correlation procedure can be mathematically expressed as,

$$\psi(\tau) = \lim_{T \rightarrow \infty} \frac{1}{2T} \int_{-T}^T x(t)y(t+\tau)dt, \quad (1)$$

where  $x(t)$  is the transmitted sequence and  $y(t+\tau)$  is the received sequence with a time delay  $\tau$ , which is supposed to contain replicas of the transmitted sequence.  $\psi(\tau)$  is the cross-correlated output which is expected to show one or more sharp peaks corresponding to reflection from the target(s).

Ideally, the CCF of the reflected M-sequence with the original M-sequence is supposed to generate a sharp peak for each reflection. If there is no reflection, it should be flat. Practically, however, the peaks are not clearly distinguishable because of spurious peaks in the CCF due to coherent as well as incoherent noise of the experimental system. So, before applying the CLEAN algorithm, some noise reduction techniques [7,8] have been applied in order to reduce the false peaks as much as possible.

## Clean algorithm

The CLEAN algorithm is basically a numerical deconvolution process devised by Hogbom in 1974 [1]. For astronomical image processing, the procedure simply amounts to break down the brightness distribution into point-source responses and then it replaces each one with the response corresponding to a "clean" beam, i.e. a beam that is free of sidelobes. Since the data type of ultrasonic pulse compression system is quite different from that of astronomical image processing, the algorithm should be adjusted so as to be applied to our experiment. For this

work, 'brightness' corresponds to the values of CCF in the processed data and 'response to a point-source' corresponds to a reference CCF pattern of the response from an identical, flawless medium. The algorithm, adapted to suit our purpose, consists of the following four steps:

**Step 1:** Obtain the clear most CCF pattern of the received data corresponding to the investigated medium (herein after referred as the CCF map (CCF2)) and that of the received data corresponding to a flawless medium (herein after referred to as the reference pattern (CCF1)) on the basis of the principle described in section 2.

**Step 2:** Find the highest peak in CCF2 and subtract CCF1 (reference pattern), including the full side lobe pattern, centered on that position. If the highest peak amplitude of CCF2 is  $\gamma$  times the corresponding highest peak amplitude of CCF1 (reference pattern), then the CCF1 (reference pattern) is multiplied by  $\gamma$  before subtraction. The value of  $\gamma$  is stored in an array to be used in Step 4 as the normalized amplitude of the corresponding peak in the processed CCF map. Then CCF2 is replaced by the result of the subtraction to get the residual CCF2 to be used in the next iteration. In short, the process can be summarised as follows:  $CCF2 = CCF2 - CCF1 * \gamma$  where  $\gamma = CCF2 / CCF1$ .

Thus the residual CCF map now contains all significant peaks corresponding to reflections except the one selected and removed by subtraction process in this step.

**Step 3:** If the renewed CCF map does not satisfy a certain criterion, return to Step 2 and repeat the procedure iteratively until all significant peaks have been removed from the CCF map. As a criterion to proceed to Step 4, one can compare the highest peak with the rms. level of the remaining CCF, look for the first time that this rms. level fails to decrease when a subtraction is made, or note when significant numbers of negative components start to appear in the resulting CCF map.

**Step 4:** Add the removed components at their respective positions, in the form of clean-beam responses, to a flat CCF map (empty map) with all peaks zero except those selected in Step 2 to obtain the new map. In the current context, the clean-beam is referred to as a triangular peak with a base width equal to two samples and with amplitude equal to the corresponding  $\gamma$  value of step2.

### Experimental setup and results:

The block diagram of the experimental setup is depicted in Fig. 1. Here the media are two identical aluminum plates of size 1200×400×4 mm, four through holes being drilled as targets in one of them. The other plate is flawless and used for collecting the reference data. The transceiver system is placed at convenient positions keeping the targets within  $-6\text{dB}$  beam spread angle of the transducer. Both transmitter and receiver are narrow-band ultrasonic transducers of identical specification (Panametrics, videoscan V194, center frequency 1.02 MHz). Data for both plates are collected in the same was

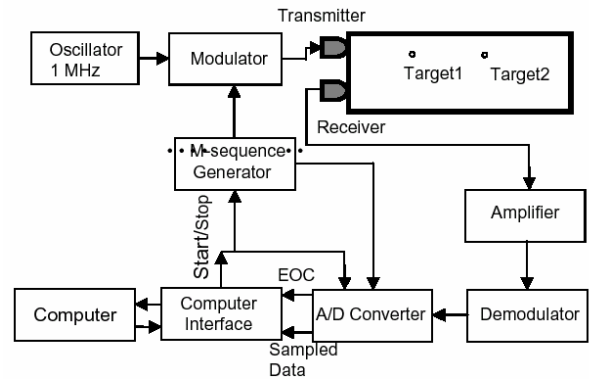

Fig.1. Block diagram of the experimental setup

and processed. Then the CLEAN algorithm is applied on the preprocessed CCF data in order to select the peaks corresponding to potential targets by selecting highest peak in each iteration. It is supposed to detect only the main peaks and exhibit them in distinct positions on the CCF map.

### Experiment-1

The experiment is performed in a metal plate of the above specification with three drilled holes. The size of the holes are 6 mm, 6.5 mm and 7 mm in diameter, which are located at 35 cm, 45 cm and 65 cm respectively from the transeiving end of the plate. A portion of typical CCF of the received raw data is shown in Fig. 2, where (a) corresponds to the CCF of reference data for the flawless medium (the reference CCF pattern) and (b) corresponds to that of the medium under investigation (the CCF map). Now to manipulate the real CCF map, data is taken from the medium with three holes. The CCFs of the data preprocessed by previously designed techniques [7,8] are shown in Fig.3, where (a) and (b) correspond to the reference CCF pattern and CCF map respectively. At this stage, it is possible to guess up to some extent about the possible peaks corresponding to potential targets. But the side lobes as well as some confusing peaks make it difficult to be sure about the exact positions of the expected peaks. Moreover, two side to side peaks within the range of peak's base width may not be clear enough to distinguish from each other. In this figure the most confusable part is at the position of 3rd peak. Although the 1st two peaks are seemingly clear, their peak positions should be determined distinctly. The 3rd peak seems to consists of three peaks, which might be the case for close faults i.e either all of them or only a few of them will correspond to real faults. At this stage, the CLEAN algorithm is applied. Fig. 4(a) shows the CCF after the implementation of the CLEAN algorithm where only four significant peaks arise stand out. The first three correspond to reflection from faults (the three separated holes) and the third one corresponds to end reflection. This figure shows that after the implementation of the CLEAN algorithm, confusable part has been cleared and the real positions of the peaks have been displayed. Also the calculation using peak positions shows the correct on flight distances from transmitter to receiver by way of corresponding targets.

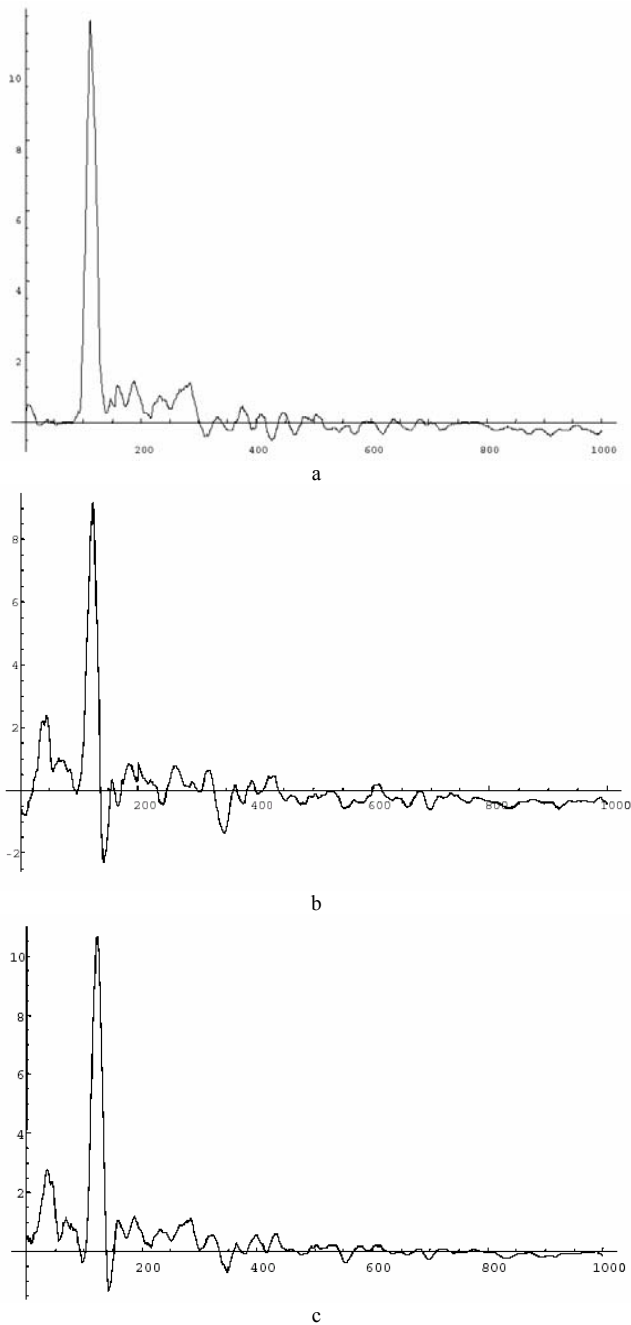

Fig. 3. Preprocessed data prior to the implementation of CLEAN: (a) Reference CCF pattern; (b) CCF map for three holes; (c) CCF map for four holes

## Experiment-2

This experiment is done with the addition of another hole in the test piece. The fourth hole (size:7.5 mm) is drilled 6 cm away from the 3rd hole at a distance of 71 cm from the transceiving end. The data is taken in the same way as in experiment 1 and the preprocessed CCF data is shown in Fig. 3c. In this figure, the biggest peak corresponds to the end reflection and the cluster of peaks on the left of it are supposed to contain the expected peaks corresponding to all the holes in the test piece. The rest of the peaks on the right of the biggest peak are possibly due

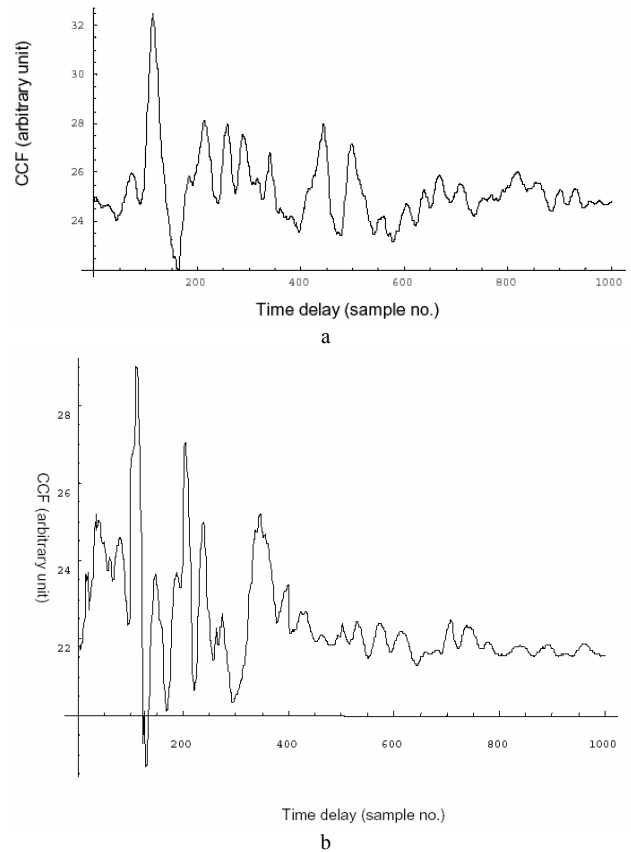

Fig. 2. Typical CCF of the received sequence (raw data): (a) For flawless medium (Reference CCF pattern); (b) For medium with holes (CCF map)

to noise. But some of these peaks (at the right side) are in fact of the same size or even bigger than second cluster of peaks on the left side which potentially contains two peaks corresponding to the last two holes. In this figure, at least nine or ten peaks, on both sides of the biggest peak, apparently seem to be genuine peaks corresponding to holes out of which only four are to be retained and all others are to be discarded. Because of closeness between peaks, side lobes become a significant factor in determining the exact position of each peak. For close peaks, these side lobes are mostly overlapping with each other as evident from this figure. At this point, CLEAN is applied to get rid of all the confusable peaks in order to retain only the peaks corresponding to holes and the end reflection. Fig. 4b shows the CCF corresponding to Fig. 3c after the implementation CLEAN where only five significant peaks stand out clearly. The first four correspond to reflection from faults (four drilled holes) and the fifth one corresponds to end reflection. This figure shows that after the implementation of the CLEAN algorithm, all the confusable parts have been cleared by discarding the false peaks. Moreover, the peak positions are also in accordance with the positions of the holes in the test piece. As for a reference to step 3 of CLEAN algorithm, the residual of the CCF map is shown in Fig. 5. This figure shows a typical condition when to stop the iteration of step 2.

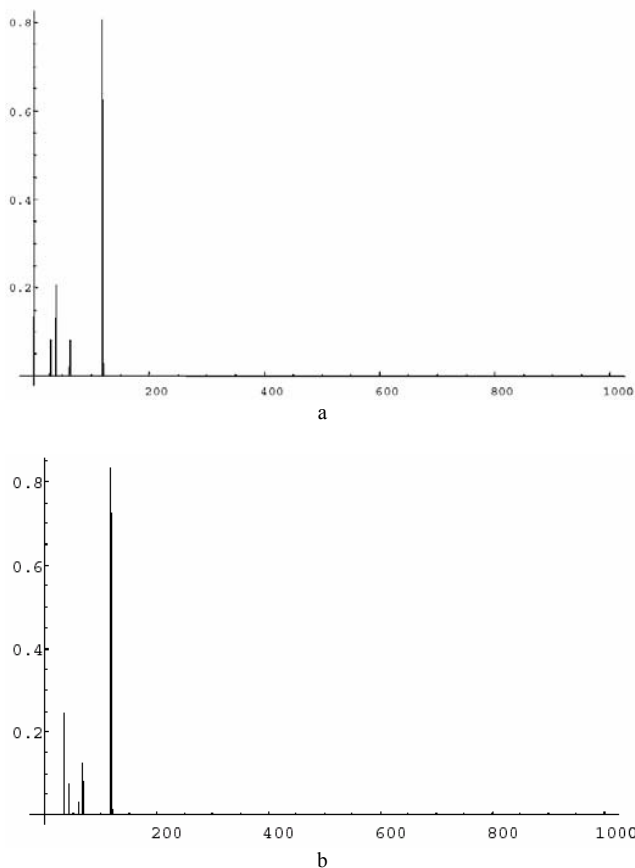

Fig. 4. Final CCF after implementing the CLEAN algorithm: a) Test piece with three holes; b) Test piece with four holes

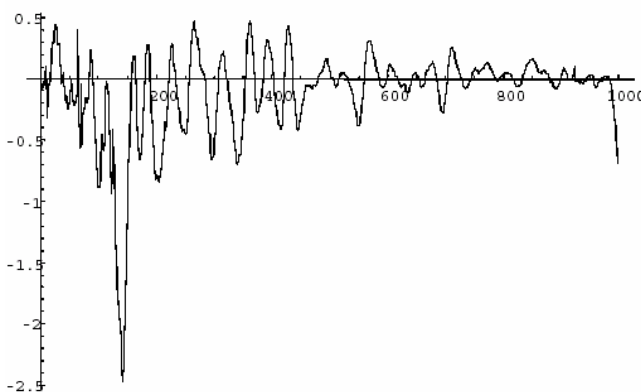

Fig. 5. The residual of the CCF map at the last iteration of CLEAN

## Conclusions

A study on the effective implementation of CLEAN algorithm is conducted for metal medium. The experiments are done in metal plate to detect reasonably small holes as close as 6 cm from each other. A good achievement of this research is that the CLEAN process, enables us to remove the side lobes completely from the CCF data and thereby it shows the potential of detecting holes very close to each other. More over it would help effectively in the discrete detection of correlation peaks in a pulse compression system. One particular application of the method can be

the acoustical detection of micro cracks or holes in pipes or pipe-like objects for periodical checking. To do that, one has to take reference data of each flawless pipe before its installation. Then, this reference data can be utilized in implementing the CLEAN algorithm for periodical checking of the pipe throughout its life. Using immersion transducers, the method might also be applicable to the distinct detection of school of fishes or underwater objects if suitable preprocessing techniques are available to obtain clear CCF of the received data. A source of error of this algorithm, as also cited by Hogbom [1], might be the criterion on which the iteration is to be stopped. In the context of complex ultrasonic NDT, the proper definition of that criterion will put forward the effective use of this algorithm. With results of this experiment, it appears that CLEAN can be made to work in other areas too with proper modifications. One of the potential area might be in ultrasonic imaging for medical use.

## Acknowledgement

One of the authors (K. M. Mahmud) would like to show his gratitude to the Ministry of Education, Japan, for supporting him with scholarship and providing the funds needed for this research.

## References

1. **Hogbom J. A.** Aperture synthesis with a non-regular distribution of interferometer baselines. *Astron. Astrophys.* 1974. Suppl. 15. P.417-426.
2. **Clark B. G.** An efficient implementation of the algorithm "CLEAN". *Astron. Astrophys.* 1980. Vol. 89. P. 377-378.
3. **Thompson A. R. et al.** *Interferometry and Synthesis in Radio Astronomy.* 1st edn. (John Wiley & Sons, Inc. 1986).
4. **Skofronick-Jackson G. M., Gasiewski A. J.** A nonlinear multispectral statistical CLEAN-based precipitation parameter-retrieval algorithm. *IEEE Trans. Geoscience Remote Sensing.* 2000. Vol. 38. P. 226.
5. **Baisch S., Bokelmann G. H. R.** Spectral analysis with incomplete time series: an example from seismology. *Computers & Geosciences.* 1999. Vol. 25. P.739-750.
6. **Gershman A. B., Turchin V. I.** Nonwave field processing using sensor array approach. *Signal Processing.* 1995. Vol.44. P.197-210.
7. **Mahmud K. M., Khan I. R., Ohba R.** Ultrasonic Soundings of Targets by Processing of Signals from Plural Receivers. *Ultragarsas (ultrasound) Journal, Lithuania.* June 2000. Nr. 2 (39). P. 7-12.
8. **Mahmud K. M., Ohba R.** Ultrasonic Fault detection by Processing of Signals from Fixed Transceiver System. *IEE Proceedings, Science, measurement and technology.* UK (in press).

M. K. Mohammad, R. Ohba

**CLEAN algoritmo naudojimas ultragarsiniuose neardomuosiuose bandymuose artimiesiems pikams impulso suspaudimo sistemoje tiksliai nustatyti**

Reziumė

Tiksliai nustatyti artimuosius atspindėtuosius pikus ultragarsinėje impulsų suspaudimo sistemoje yra sudėtinga dėl pagrindinio piko be išorinio lapelio dalinės sanklotos. Ši problema gali būti išspręsta remiantis pagrindiniais lauko algoritmo principais. CLEAN algoritmas, kuris dažnai naudojamas radioastronominių tyrimų duomenims apdoroti, puikiai tiko ultragarsiniams bandymams, tiksliau, artimiesiems pikams atskirti ir šoniniams lapeliams visiškai pašalinti. Šis algoritmas buvo sėkmingai panaudotas artimoms skylėms metalo plokštėse surasti. Aptartos šio metodo taikymo sritys.

Pateikta spaudai 2003 12 19

DOI: 10.5755/j01.u.50.1.8269