

The use of ultrasound for investigation of glazing units

J. Butkus, A. Vladiškauskas, L. Jakevičius

Prof. K.Baršauskas Ultrasound Institute

Kaunas University of Technology

Introduction

The area of windows at dwelling houses in Lithuania is more than 15.4 million square meters [1]. The heat losses through the windows are about 3.74 billion kWh, or about 21% of all the losses over the heating season [1]. The total annual heating lost through the windows costs about 0.5 billion Lt. According to the Lithuanian Building Code STR 2.05.01.:1999 "Thermal Technique of the Building Envelope" the required heat transmission value of a window $U=1.9 \text{ W/(m}^2\text{K)}$ [1]. The real U -value of windows in existing buildings is 2.3-2.8 $\text{W/(m}^2\text{K)}$, and is 1.3 times worse the required [1].

Improved thermal insulation of windows may be achieved by using double pane glazing with low emissivity coatings and by using argon (Ar), krypton (Kr) or xenon (Xe) as filling gas between multiple glass panes [1,2]. Recently in Lithuania the argon is mostly used as a gas filling glass panes, while in West Europe heavy noble gases (Kr and Xe) has become more and more economically feasible [2]. The use of argon improves the thermal insulation of window more than 1.3 times with respect to air (Fig.1) [2].

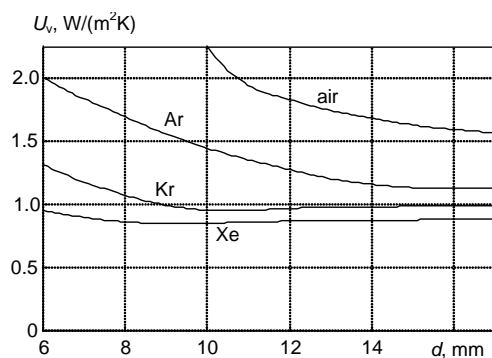

Fig.1. The dependence of the heat transmission U of the double pane glazing units filled with air, argon, krypton or xenon on the distance d between glass panes

How one can see from Fig.1, the use of heavy noble gases krypton and xenon improves this property 2...2.25 times with respect to air. But these gases are more expensive and are seldom used in Lithuania. However the process of gas filling of glazing units in Lithuania is not completely controlled [1] and the composition of gas inside the unit is not exactly known. Another serious problem of the gas filled glazing units is the gas leakage of the insulating glass units. This is a severe problem because replacing the original noble gas filling with air results in decrease of the thermal insulation to nearly 30...100% (Fig.2).

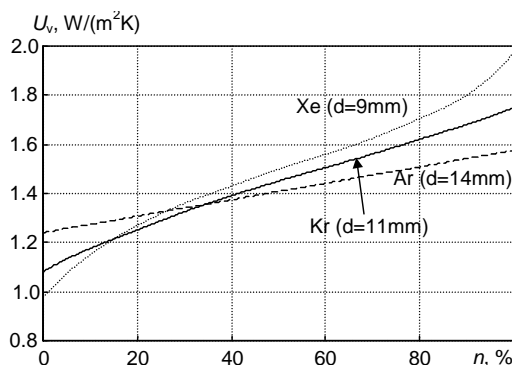

Fig.2. The dependence of the heat transmission U of windows filled with noble gas and air mixtures on the air concentration between glass panes

It is possible to inspect the composition of the gas filling by dismantling the unit, drilling a hole through the rim seal and extracting and analyzing the filling gas. But this procedure is very expensive and is not applicable for wide scale tests. Recently for that purpose nondestructive ultrasound methods were proposed [2]. These methods can be applied in situ, without necessity to unmount the glazing from its frame. It would provide the cost effectiveness and flexibility to conduct tests of large number of highly insulating rare gas filled glazing units. The solution of the problem of determining the composition of the gas filling in glazing units is based on the variation of the sound velocity of gas mixtures with composition [2]. However this method has not been used on a large scale and is in the initial stage of investigation. Therefore the aim of this investigation was to reveal some aspects of the use of ultrasound velocity measurement for determining the composition of the gas filling in glazing units.

Theory

The speed of sound in an ideal gas at a constant pressure is

$$c = \sqrt{\frac{\gamma RT}{M}}, \quad (1)$$

where $\gamma=c_p/c_v$ denotes the specific heat ratio; R is the universal gas constant; T is the absolute temperature and M is the molar mass, respectively. In accordance with theory and proposals submitted in [2], the sound velocity in the gas mixture is given by

$$c = \sqrt{\left(\frac{1}{\frac{x_1}{\gamma_1 - 1} + \frac{1 - x_1}{\gamma_2 - 1}} + 1 \right) * \left(\frac{RT}{x_1 M_1 + (1 - x_1) M_2} \right)}, \quad (2)$$

where x_1 and x_2 are the molar fractions of a mixture of two ideal gases, with $x_1+x_2=1$. The molar mass of a mixture is given by $M=x_1M_1+x_2M_2$. By using the values of molar mass and specific heat ratio presented in [2] and Eq. 2 it was calculated the sound velocity in the noble gas and air mixture when air concentration is increased from 0 to 100%. The results of calculation are showed in Fig.3.

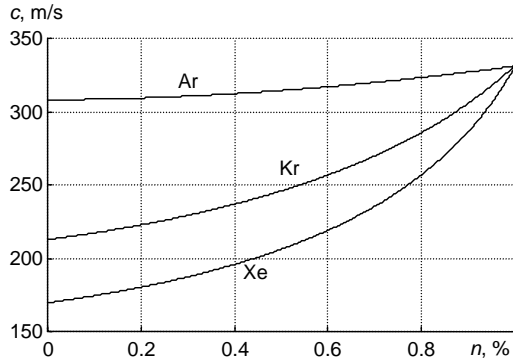

Fig.3. The dependence of sound velocity in the noble gas and air mixtures, when air concentration is increased

How one can see from Fig.3, when the temperature is constant, the smallest variation of sound velocity is obtained when the concentration of air is increased in air-argon mixture. Therefore, the determination of air concentration in argon-air mixture is more difficult in comparison with other noble gases. This is seen in Fig.4, where the dependencies of rapidity dc/dn of sound velocity alteration (dc) on concentration (n) of air in the noble gases and air mixtures are shown.

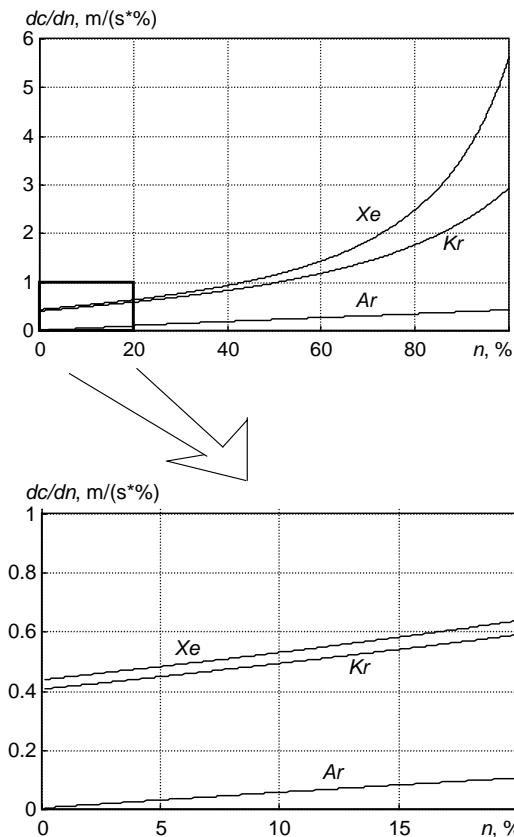

Fig.4. The dependencies of rapidity dc/dn of sound velocity variation versus concentration of air in the noble gases and air mixtures

How one can see from Fig.4, the dependence of the rapidity dc/dn of sound velocity variation versus concentration of air in the air and argon mixture is very small ($\Delta c=1\text{cm/s}$), when the air concentration in air-argon mixture is about 1%. The rapidity dc/dn of sound velocity variation versus concentration of air in the air and argon mixture changes from $0.1\text{m}/(\text{s}\cdot\%)$ to $0.35\text{m}/(\text{s}\cdot\%)$ when the concentration of air increases from 20% to 90%. These values of dc/dn can be easily fixed by measuring sound velocity in gaseous media. In the case when glass units are filled by krypton or xenon, the changes of rapidity dc/dn alters from $0.4\text{m}/(\text{s}\cdot\%)$ to $3\text{...}3.5\text{m}/(\text{s}\cdot\%)$ when air concentration increases from 1% to 100%. Therefore the measurement of air concentration in the mixtures with krypton or xenon is really feasible.

How one can see from the Eq. 1, the sound velocity in the gases is strongly dependent on the gas temperature. The calculations showed that in the region of temperatures 15°C - 25°C , the change of sound velocity corresponding to 1°C temperature alteration leads to $\Delta c_t=0.6\text{m/s}$ for air, $\Delta c_t=0.55\text{m/s}$ – for argon, $\Delta c_t=0.38\text{m/s}$ – for krypton and $\Delta c_t=0.31\text{m/s}$ – for xenon. Therefore the gas temperature must be evaluated when the filling of glazing units with noble gases is analysed on the basis of sound velocity measurement. In accordance with the European Standard EN 1279 [5] the concentration of noble gas inside the glazing unit may alter from $90\%+10\%$ to $90\%-5\%$ of its nominal value. Therefore about 10% of the gas inside the glazing unit may be air. At that concentration of air inside glazing unit $dc/dn=0.058\text{m}/(\text{s}\cdot\%)$. In such a way, if 1% change of air concentration is to be fixed, the temperature of gas mixture inside the glazing unit must be evaluated not worse than 0.1°C . If the concentration of air is increased to 20%, the change dc of sound velocity corresponding to 1% alteration of air concentration increases to 0.11m/s . Therefore the demands to the temperature measurement accuracy decrease to 0.18°C . After the filling of glazing units by krypton or xenon the requirements for accuracy of temperature measurement decreases 4...5 times and there are no difficulties for temperature measurement in practice.

An influence of gas humidity, when measuring air concentration inside the glazing units, is small enough. This is due to insignificant dependence of sound speed in air on humidity [3,4]. The change of air humidity from 0% to 100% leads to the alteration of sound velocity only by 0.37% [4]. The humidity of gas inside the glazing unit compiles only a few per cents, because the desiccant is used, and a dew point is reached only when the temperature falls lower than minus 60°C [5].

Evaluation of acoustic losses

The air coupled and contact ultrasonic technique has become a reliable and indispensable in nondestructive measurements. This technique can be successfully used for the measurements of filling the glazing units with the noble gases or gas-air mixtures. In addition, ultrasonic waves can be used for monitoring the glazing units long-term time after the setting in the windows.

A basic problem when using ultrasound method, is to get the ultrasonic signal from the glazing unit, which is a multi-layer structure, consisting of solids and gases. Because of the low transmission efficiency between solids and gases, only a small portion of energy is transmitted to the next medium. There are several techniques available to overcome this problem and make ultrasound an efficient and reliable for measurement properties of gases:

- to apply proper and effective measurement methods;
- to use high voltage transmitters and to apply tone burst to resonant transducers;
- to increase sensitivity of the receiving transducer combined with low-noise preamplifiers;
- to use matching layers for reducing impedance mismatch losses.

The objective of this part was to investigate the losses of transmission of ultrasonic waves through the glazing unit and to obtain information about the properties of gases. For this purpose the pulse-echo technique or the through-transmission technique can be used. A modification of the pulse-echo technique uses separate transmitting and receiving transducers or two angle type transducers on one side of the glazing unit. In some cases the windows cannot be opened and are therefore accessible to measurements only from one side. The through-transmission is most of all suitable for measurement of gas concentration in the glazing units, because it gives very good sensitivity. But this technique is limited by the need to access both sides of the glazing unit and to coordinate the setting of two transducers.

The noble gases have different acoustical parameters (table 1), which also depend on temperature.

Table 1

Gas	ρ , kg/m ³	c , m/s (0°C)	c , m/s (20°C)	Z , kg/m ² s (0°C)	Z , kg/m ² s (20°C)
Air	1,293	331,2	343,2	428,2	456,4
Argon	1,784	308,0	318,8	549,4	568,7
Krypton	3,744	212,6	220,1	795,8	824,0
Xenon	5,897	168,9	175,4	996,0	1037,2

According to Table 1, the xenon is best of all, having the lowest of ultrasound waves velocity and the largest acoustic impedance. But the acoustic impedance mismatch between the glass sheets and gas gives very small transmission of the ultrasonic waves. Therefore, it is necessary to look for suitable methods to improve the ultrasonic wave propagation.

The concentration of noble gases can be measured by using the following methods:

- non-contact (Fig.5);
- contact through transmission (Fig.6);
- contact-echo (Fig.7);
- mixed (Fig.8).

The non-contact methods are very convenient without the pressure to the glazing unit and without a couplant. The air surrounding glass panes is used as the couplant. It allows to change the distances between the transmitting or the receiving transducers and the glazing unit. Moreover, it

allows to change the incidence angle of ultrasonic beam for excitation of the shear waves in the glass sheet (Fig.5.b). As the longitudinal ultrasonic waves inside the glazing unit undergo multiple reflections, the received ultrasonic signals enable to measure not only the gas concentration, but also the distance between the glass panes.

The transmission coefficient of ultrasonic waves is (Fig.5a):

$$D_u = K_t(j\omega) * K_r(j\omega) * D_a(j\omega) * 2D_g(j\omega) * D_1(j\omega) * D_2(j\omega), (3)$$

where $K_t(j\omega)$, $K_r(j\omega)$ are the transmission coefficient of the transmitting and receiving transducers, respectively; $D_a(j\omega)$ is the transmission coefficient of the gas layer; $D_g(j\omega)$ is the glass pane transmission coefficient; $D_1(j\omega)$, $D_2(j\omega)$ are the air transmission coefficients between the transmitter, the receiver and the glazing unit.

Two factors determine possibilities of the gas concentration measurement in the glazing units as they compile about 90% of the losses of ultrasonic waves. They are:

- transfer coefficient of transducer;
- transmission coefficient of ultrasonic wave through the glass sheet.

The transfer function of the transducer [6]

$$K(j\omega) = -\frac{hD}{2Z_0} D_{01} \frac{1 - D_{02} e^{-j\omega l/v} e^{-\alpha\omega l/v} + R_{02} e^{-j2\omega l/v} e^{-2\alpha\omega l/v}}{1 - R_{01} R_{02} e^{-j2\omega l/v} e^{-2\alpha\omega l/v}} (4)$$

depends on the piezoelectric properties and the damping of the piezoelement. The strong mismatching of acoustic impedance impedes considerably the radiation of ultrasonic transducer into gas media. Owing to this strong mismatching, the acoustic transmission coefficient on the

transducer-gas boundary is very small (-90dB) and transducer works in the narrow frequency bandwidth. To improve the transmission coefficient matching layers are used [7,8]. Then the losses of two way transmission achieve - (40-90) dB. The transmission coefficient of ultrasonic waves through a glass sheet is given by

$$D_s(j\omega) = \frac{D_{01} D_{02} e^{-\alpha\omega l/v} e^{-j\omega l/v}}{1 - R_{01} R_{02} e^{-2\alpha\omega l/v} e^{-2j\omega l/v}}, (5)$$

where,

$$R_{01} = \frac{Z_0 - Z_1}{Z_0 + Z_1}, (6)$$

$$R_{02} = \frac{Z_0 - Z_2}{Z_0 + Z_2}, (7)$$

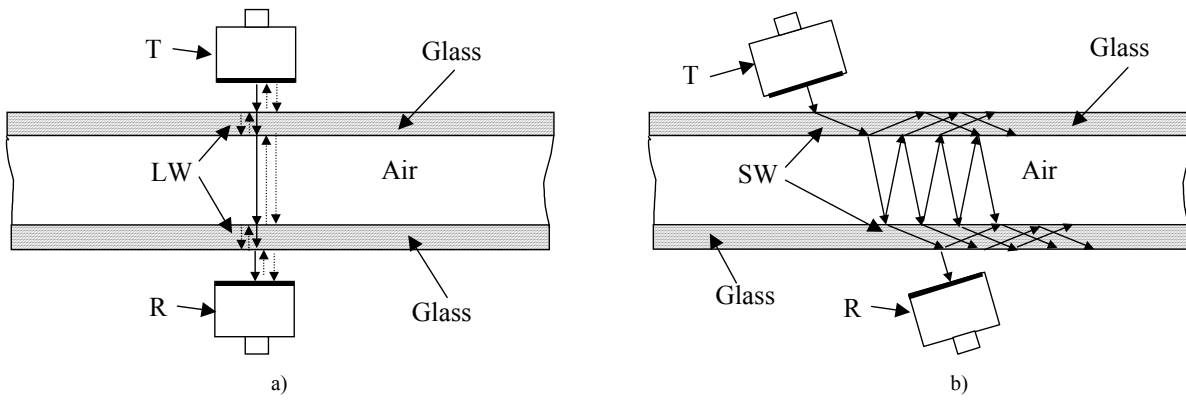

Fig.5. Non-contact methods of measurement of gases concentration: a) by longitudinal waves (LW), b) by longitudinal-shear waves (LSW)

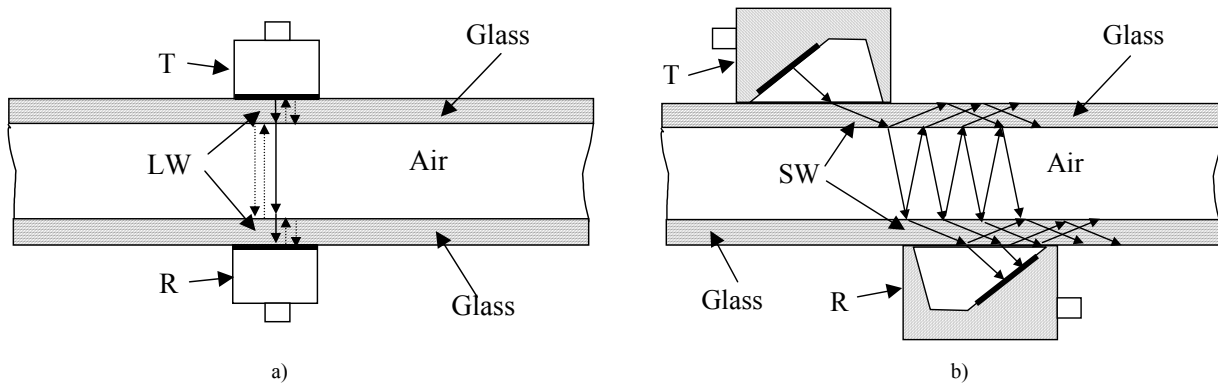

Fig.6. Contact through methods of measurement of gases concentration: a) by longitudinal waves, b) by longitudinal-shear waves

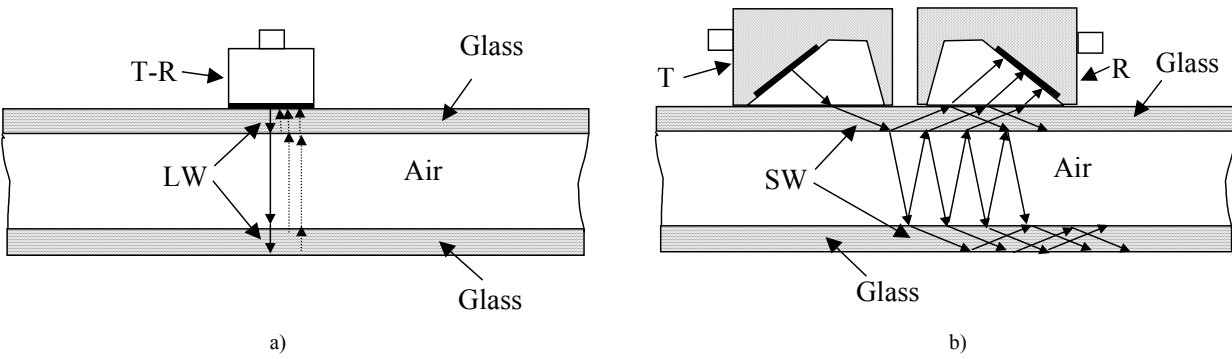

Fig.7. Contact echo methods of measurement of gases concentration: a) by longitudinal waves, b) by longitudinal-shear waves

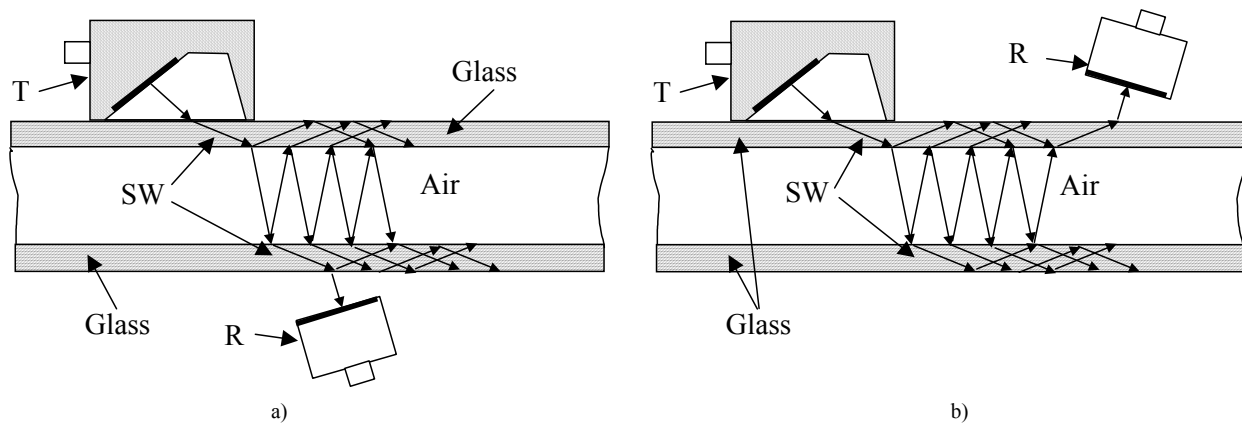

Fig.8. Mixed methods of measurement of gases concentration: a) through transmission method, b) echo method

$$D_{01} = \frac{2Z_1}{Z_0 + Z_1}, \tag{8}$$

$$D_{02} = \frac{2Z_0}{Z_0 + Z_2}, \tag{9}$$

Z_0 is the acoustic impedance of glass, Z_1, Z_2 are the acoustic impedances of the surrounding gas; R_{01}, R_{02} are the reflection coefficients of glasses: glass– the first gas medium and glass – the second gas medium; D_{02}, D_{01} the transmission coefficients: glass – the first gas medium and glass – the second gas medium, respectively.

The losses of transmission of ultrasonic waves through glass pane make up – (50-60) dB. Because ultrasonic waves must pass the glass pane twice, the losses increase also two times – (100-120) dB. The attenuation losses in the glass sheet can be neglected.

Table 2

Nr	Method of measurement	$K_s(j\omega)K_i(j\omega)$	$2D_s(j\omega)$	$2D_1(j\omega)$	$D_1(j\omega)D_2(j\omega)$	Total losses
1	Non-contact	-(40...90)dB	-(100...120)dB	-(1...5)dB	-(1...12)dB	-(142...237)dB
2	Contact	-(20...70)dB	-(50...60)dB	-(2...10)dB	-	-(72...140)dB
3	Mixed	-(30...80)dB	-(70...90)dB	-(1...5)dB	-(1-6)dB	-(102...181)dB

The losses of ultrasonic waves propagating in air [9] depend on its temperature, pressure and humidity as well as on the frequency of ultrasonic waves and the distance of propagation. The losses of the acoustical signal in the measuring channel of noble gas concentration are presented in Table 2. The total losses of non contact method reach - (142-237) dB.

The improvement of the transmission of ultrasonic waves through the glazing unit can be achieved by using the contact method of measurement (Fig.6). In this case only two boundaries of glass-gas remain. It considerably decreases the losses of transmission of ultrasonic waves through the glazing unit and the transmission coefficient of transducers (Table 2, case 2). In addition, the contact method has no losses of ultrasonic waves in air, but there are losses in the contact liquid due to mismatch of the acoustic impedance of the radiation surface of the transducer and glass. Application of longitudinal-shear waves in the glass pane (Fig.6.b) gives reduction of the transmission losses additionally about 6dB. Hence, this measuring method is preferable.

The contact echo methods are very attractive (Fig.7), because they are extremely convenient for measurement of glazing units in the windows of buildings. When contact echo methods are used the losses of ultrasonic waves increase slightly, due to two reasons. The first is attenuation of ultrasonic waves due to a double distance inside the glazing unit. The second are the losses due to reflection at the boundary gas – glass (coefficient of reflection $R=0.998$).

The mixed method (Fig.8) includes one contact transducer and one air-coupled transducer. The transducers can be located on one side of the glazing unit (Fig.8a) or on the both sides of glass panes (Fig.8b). At that case, one

additional boundary increases the losses of the ultrasonic waves about 30 dB.

Conclusions

It was shown that the determination of the composition of gas mixtures filling glazing units is possible with ultrasound. The temperature of gas mixture must be evaluated if the concentration of air in the noble gas and air mixtures is determined by measuring sound velocity. The demands for gas temperature measurement accuracy decreases, when concentration of air in noble gas and air mixtures is increased. It is shown that the use of ultrasound method for the measurement of gas concentration is limited by multi-layer structure of glazing units. On the basis of investigation of acoustical parameters of the noble

gases the ultrasound methods of sound velocity measurement inside glazing units are discussed. It is shown, that the application of longitudinal-shear waves in the glass panes of windows gives reduction of the transmission losses. They are more preferable for investigation of glazing units by ultrasound. The contact echo methods are very attractive because they are very convenient for measurement of noble gas concentration between the glass panes of the windows.

References

1. Window Modernization in the Baltic Nations: Problems and Opportunities. Proceedings of the International Workshop. Institute of Architecture and Construction. Kaunas. Technologija. 2000. P. 138.
2. **Gross J., Fricke J.** Non-destructive In-Situ Determination of the Rare Gas Content of Highly Insulating Glazing Units. Insulating Materials: Testing and Applications. 1997. Vol.3. P.61-62.
3. **Wong G. S. K.** Speed of Sound in Standard Air. J. Acoust. Soc. Am. 1986. Vol. 77. No.5. P. 1359-1366.
4. **Wong G. S. K.** Variation of the Speed of Sound in Air with Humidity and Temperature. J. Acoust. Soc. Am. 1985. Vol. 77. No.5. P. 1710-1711.
5. **European Standard EN 1279-3** Glass in building – Insulating glass units – Part 3: Long term test method and requirements for gas leakage rate and gas concentration tolerances. European Committee for Standardization. 2002. P.27.
6. **Vladišauskas A.** Investigation of the influence of losses on the characteristics of plate transducers. Ultragarsas.1986. No.18. P. 56-64 (In Russian).
7. **Bhardwaj M. C.** High transduction piezoelectric transducers and introduction of non-contact analysis. NDT. 2000. Vol. 5. No.01. P. 1-21.
8. **Opielinski K., Gudra T.** Influence of the thickness of multilayer matching systems on the transfer function of ultrasonic airborne transducer. Ultrasonics. 2002. Vol. 40. P. 465-469.
9. **Vladišauskas A., Jakevičius L.** Absorbition of ultrasonic waves in air. Ultragarsas. 2004. No.1(50). P. 46-49.

J. Bukus, A. Vladišauskas, L. Jakevičius

Ultragarso panaudojimas langų stiklo paketams tirti

Reziumė

Tirtos galimybės nustatyti langų stiklo paketus užpildančių dujų sudėtį. Parodoma, kad oro koncentracija stiklo paketus užpildančių oro ir inertinių dujų mišiniuose gali būti nustatoma matuojant garso greitį stiklo paketo viduje. Nustatant oro koncentraciją, būtina įvertinti inertinių dujų ir oro mišinio temperatūrą. Pagrindinė problema, taikant ultragarsinį

metodą, yra gauti ultragarsinį signalą nuo stiklo paketo, kuris yra daugiasluoksnė struktūra, susidedanti iš kietųjų kūnų ir dujų. Pateikiami inertinių dujų ir oro akustiniai parametrai ir aptariami ultragarsiniai metodai garso greičiui dujų mišiniuose nustatyti. Apskaičiuoti siunčiančių ir priimančių keitiklių bei ore esančių stiklo paketų perdavimo koeficientai. Pranašiausi yra kontaktiniai aido metodai, kadangi jie labai patogūs įstatytiems į pastatų langus stiklo paketams tirti. Naudojant išilgines-skersines akustines bangas galima sumažinti perdavimo nuostolius paketų stikluose ir tinkamiausiai atlikti ultragarsinius matavimus.

Pateikta spaudai 2004 05 31

DOI: 10.5755/j01.u.51.2.8322