

Research of the tangential movement of the tactile device

M. Ažubalis¹, R. Bansevicius², R. T. Toločka³, V. Jurėnas⁴

¹ Kaunas University of Technology, Kęstučio 27, Kaunas, LT-3004, Lithuania, E-mail: mindaugas.azubalis@ktu.lt

² Kaunas University of Technology, K. Donelaičio 70, Kaunas, LT-3004, Lithuania, E-mail: bansevicius@cr.ktu.lt

³ Kaunas University of Technology, A. Mickevičiaus 37, Kaunas, LT-3000, Lithuania, E-mail: tadas.tolocka@ktu.lt

⁴ Kaunas University of Technology, Kęstučio 27, Kaunas, LT-3004, Lithuania, E-mail: vytautas.jurenas@ktu.lt

Introduction

With the exploration of tactile devices arises a couple of tasks and they should be performed to answer some questions about transmission and of perception of information. There are a lot of investigations performed on blind people behaviour and the responsiveness to the tactile data, but those methods have limited capabilities of tactile data evaluation [1]. Considering this we have made an assumption that choosing the method of the evaluation of the data transmitted to a blind or visually impaired user is conditioned by the distinctive features of tactile devices, such as construction, etc. Our case reveals one property – the way of data transmission. That feature of tangential pin movement is caused by shortening of the construction and needs appropriate measurement tools.

The area of exploration of the tactile information is closely interlaced with the measurements of skin deformation. It is a basic factor that estimates the strength of deformation. There are also other investigations about the relation between skin deformation and perception of it [2].

The results of two experiments are presented. The experimental measurements were performed to investigate the main characteristics of the tactile device – the capability to produce and transmit tactile data. This is implemented with a tangential movement of the magnetic actuator.

The tangential movement is an exceptional feature of this device. Usually, the pins of tactile devices moves in the vertical direction: up and down [3].

The complexity of the tactile perception is the main issue when the tactile devices are investigated. Normally researchers rely on an opinion of a user (e.g. blind or visually impaired person) opinions [4]. The point is that you can not estimate quality of transmitted data by just relying on an operator's opinion. The perception depends on a lot of factors: skin sensitivity, which depends on the age, roughness, speed and frequency in which information was transmitted [5].

In our case we traced the movement of the magnetic actuator in two ways: the autocorrelometer with laser and CCD camera and the Doppler vibrometer.

Small dimensions of the magnetic actuator, not enough space in the vicinity of the actuator were the main reasons why the non-contact measuring method was chosen. The laser was chosen because of the capability of non-contact

measurement and the simplicity of implementation of the experiment.

The Doppler vibrometer OMETRON was chosen for its simply use. It measures speed of vibration of an object.

As we had no possibilities to contact a blind or visually impaired person for any investigation, we were obliged to rely on an appropriate experiments performed by other researchers.

In our case there was an attempt to compare the needles vibration to data of human tactile perception.

The measurement of marginal values of magnetic actuator run

The measurement of the marginal values of the magnetic actuator requires such an equipment as the He-Ne laser LGN-207B, a mirror, a telescope the magnifying factor of which is about 6, the lens with the focal length of 400 mm, a small mirror connected onto magnetic pin, a vibrator (not shown in the picture) and CCD camera, which is connected to a personal computer. The measurement scheme is presented in the Fig. 1. The stability of the measuring system is obtained using vibration proof STANDA measuring table.

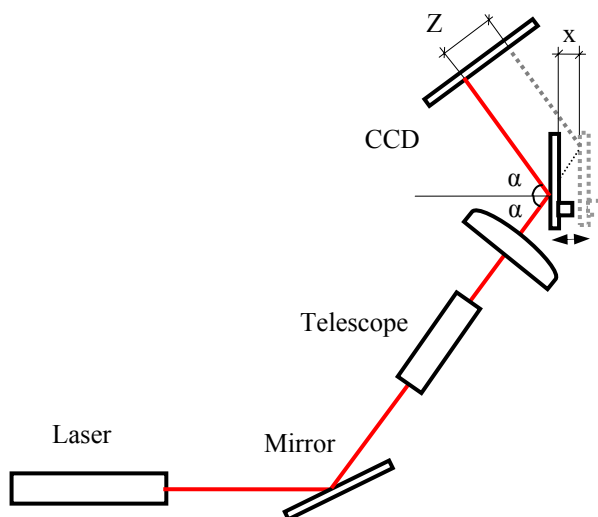

Fig.1 Scheme of experiment performed with LGN-207B laser

The tactile device is fixed tight in a jig which is connected to the measuring table. The vibrator gives oscillations of 2 Hz to a pallet. The pin of the magnetic

actuator, which are a part of the tactile device and is tackled inside the device and is hold by two springs, is attracted to this pallet with 30 Hz frequency. This frequency was selected for the couple of reasons. According to this it was made an assumption that this kind of the signal delivers a better sensitivity to a blind person. According to this it was made an assumption that higher frequency determines more accurate results of marginal values.

The input signal parameters for the magnetic actuator were set according to literature and experimental findings. One of the reasons for such a low level of a signal was that the current can not exceed the critical value what could cause damage to the winding of the magnet. One of the tasks for the oncoming research is to find out the dependence between the current and the temperature of the windings.

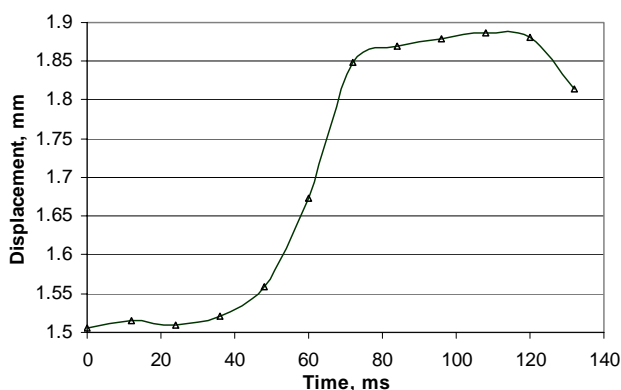

Fig.2 Results of the experiment performed with He-Ne laser LGN 207B, the time step is 12 ms

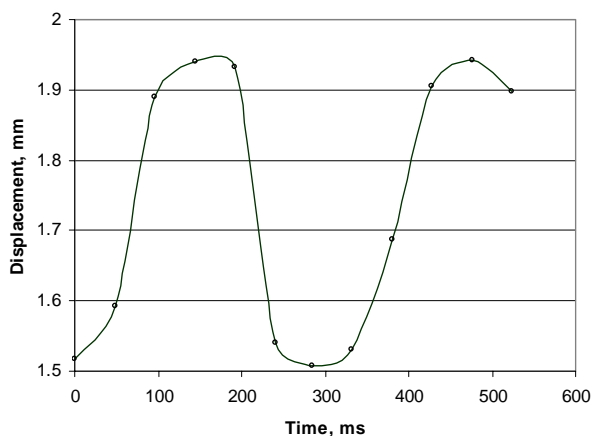

Fig.3 Results of the experiment performed with with He-Ne laser LGN 207B, the time step is 48 ms

Blind persons often read a text by both hands. Mostly it is not enough to stroke once through a text. This procedure should be repeated at least once. Considering this, the speed of the Braille reading pad frequency should be set to 2 Hz. This means that a finger touches the pin 2 times in a second. This enables us to perform a measurement, where the pin moves to the both directions: left and right. This way we can suppose that Braille text is read with a finger moving along the pin in a repeating manner. The experiment was also determined and

restricted by software capabilities. The minimal time lag between two read points could be only 12 ms. That disadvantage was a great problem that disabled the dynamic observation of movement of the pin during data transmission.

The software could record 12 shots with 12 milliseconds time lag. Each shot was presented as a curve with one maximum bump. That value was tied in with the recorded time and we obtain the curve that is presented in Fig. 3. The smallest step of 12 ms enables us to trace just a short range of magnet movement.

In order to obtain more exact figures of the magnet moving with respect to time, the time step were increased twice. Every time after change of the time step value the curves of the magnet movement were made.

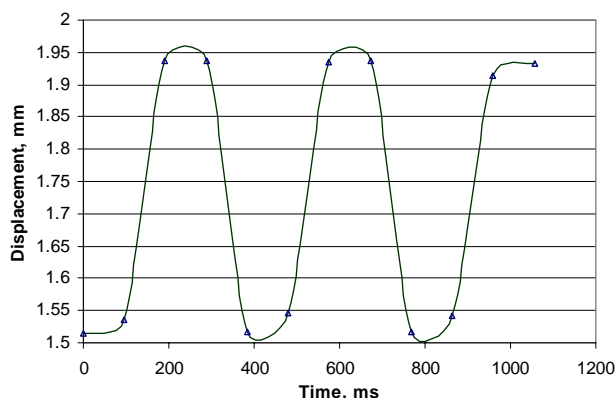

Fig.4 Results of the experiment performed with He-Ne laser LGN 207B, the time step is 48 ms

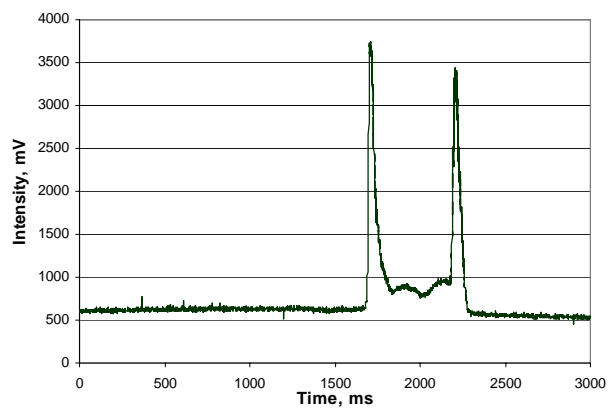

Fig.5 Results of the experiment performed with He-Ne laser LGN 207B, the time step is 48 ms

The results of the displacement are shown in Fig. 4, 5 and Fig. 6. Particularly informative is Fig.6, were both marginal values of the movement are depicted. The time step was set to 0,5 second. This is a period of 2 Hz movement which was set to the vibrator.

The settlement of the true angle of the laser beam that falls into the object mirror was calculated by performing usual geometrical actions (Fig.1). Firstly, a triangle was made, where one angle is the incidence angle the another one – the right angle. There we have two parallel triangles where one side is common, two angles near this side is known as α . Finally, the displacement of pin x can be expressed as

$$x = \frac{z}{2 \cdot \sin \alpha}, \quad (1)$$

where x is the displacement in millimeters, $z = N \cdot 7 \cdot 10^{-3}$ is indication of autocorrelometer in millimeters, N is the number of pixels read from autocorrelometer, α is the incidence angle of the laser beam. The length of the wave produced by a laser beam is 632,8 nm. The value of one pixel of the autocorrelometer is a half of the length of the wave:

$$p = \frac{\lambda}{2} = \frac{0.6328}{2} = 0.3164 \mu\text{m}. \quad (2)$$

Measurement of the vibration dynamic behaviour of the tactile system

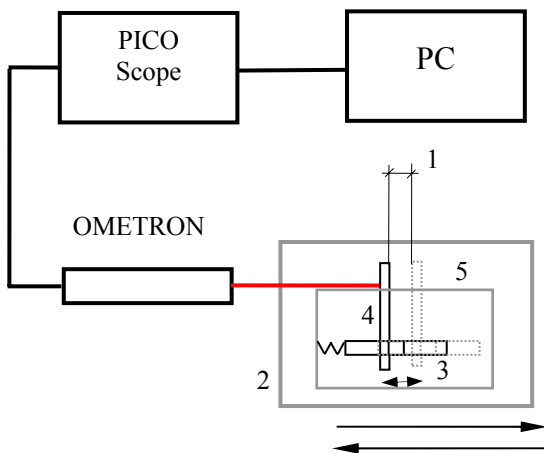

Fig. 6. Scheme of measurement performed at Kaunas university of technology

The second experiment performed with the tactile actuator was a dynamic vibration measurement of the magnetic core movement. The scheme of the experiment is shown in Fig. 3. It consists of a personal computer, a virtual instrument Picoscope, which enables to read two signals simultaneously, the laser Doppler Vibrometer VH300+. The tactile actuator 3 is placed onto a moving workbench of the machine-tool 2, which performs a reciprocate movement. Also, the tactile actuator 3 is connected stiffly with the mirror 4 and is placed inside the housing 5. The laser beam is pointed into the mirror 4.

The laser Doppler vibrometer OMETRON VH300+ was chosen for its simplicity and suitability for that measurement. It enables data to be collected from a wide range of applications, and make them available for a conventional analysis. The vibrometer is directly related to the wavelength of light.

The moving workbench of the machine tool where the magnetic system is situated (is close but not touching it) is moving at the speed 1120 mm per minute [6].

The rectangular signal with the amplitude of 2 volts and 30 Hz of frequency is sent to a magnet. In the result window it appears distorted by a parasitic capacity in the circuit.

As it was mentioned above, a positive signal is when the test surface is moving towards the laser device and negative, when the test surface is moving away from it.

The positive signal means that we are trying to imitate that mouse moving towards the laser, from the right side to the left, the negative signal means that the mouse is moving away from the laser, from the left side to the right.

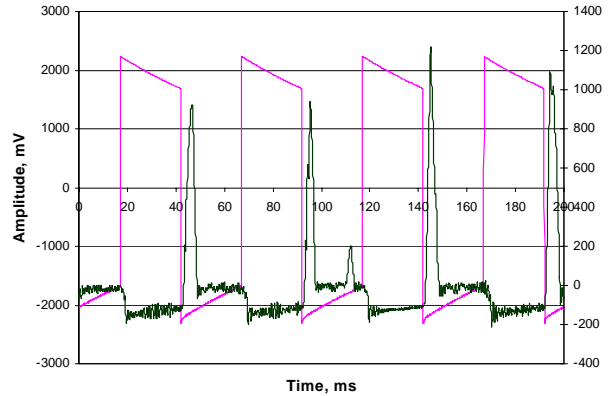

Fig.7. Workbench is moving towards the laser, frequency 20 Hz, amplitude 2 V

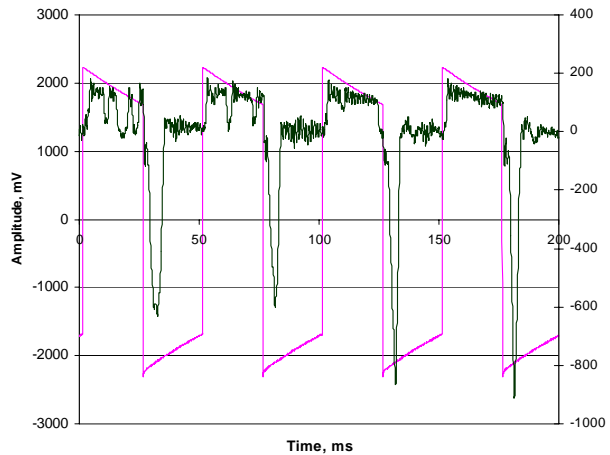

Fig.8. Workbench is moving away from the laser, frequency 20 Hz, amplitude 2 V

From Fig. 8 it is obvious that a spring own frequency is 82 Hz.

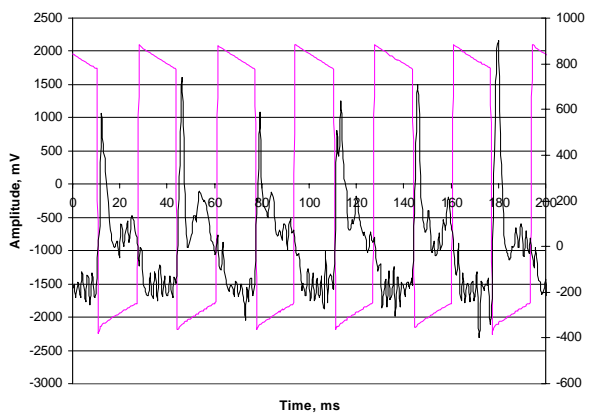

Fig. 9. Workbench is moving towards to the laser, frequency 20 Hz, amplitude 2 V

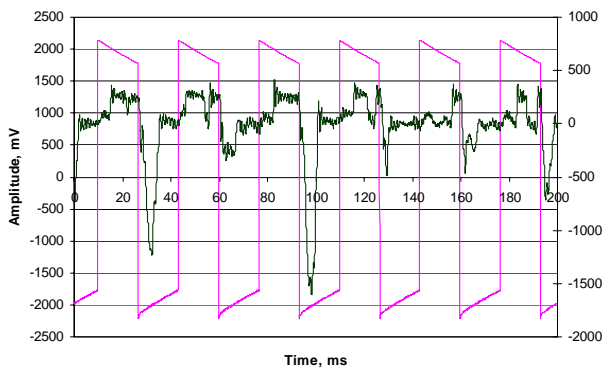

Fig.10. Workbench is moving away from the laser, frequency 30 Hz, amplitude 2 V

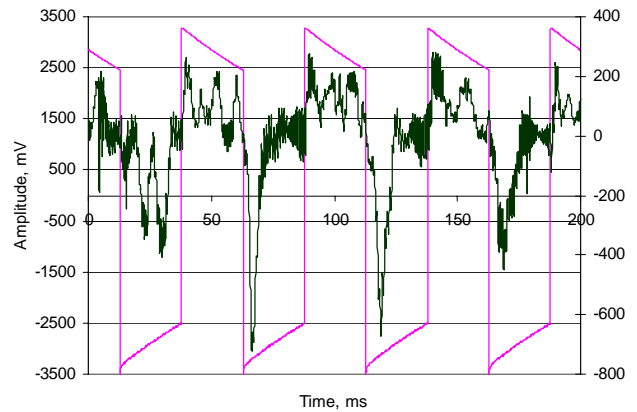

Fig. 13. Workbench is moving away from the laser, frequency 20 Hz, amplitude 3 V; the surface is tainted with oil

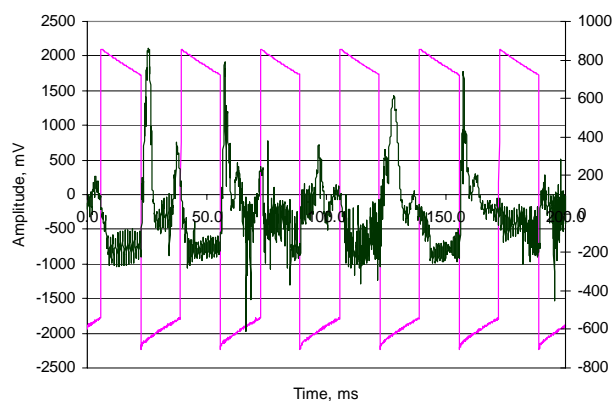

Fig. 11. Workbench is moving towards to the laser, frequency 30 Hz, amplitude 2 V; the surface is tainted with oil

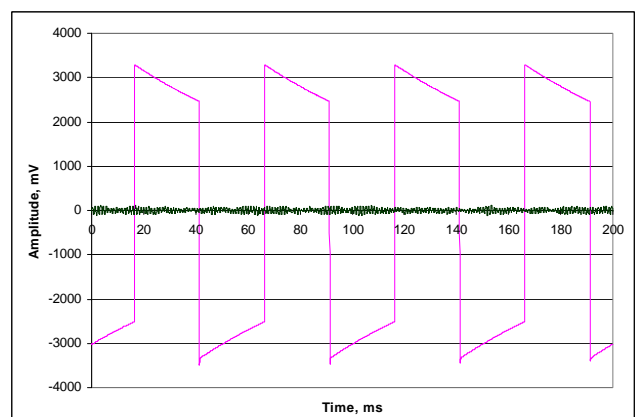

Fig. 14. Workbench is moving towards to the laser, frequency 20 Hz, amplitude 3 V; the surface is tainted with oil

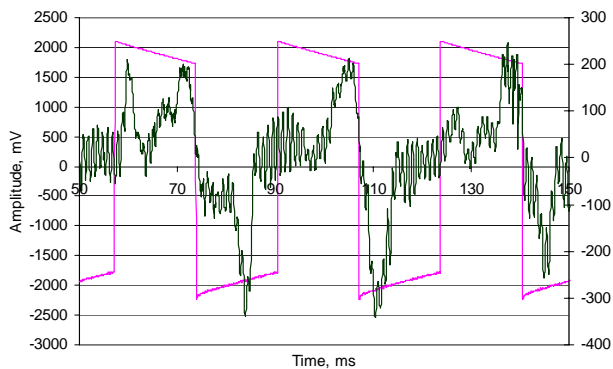

Fig. 12. Workbench is moving away from the laser, frequency 30 Hz, amplitude 2 V; the surface is tainted with oil

In Fig. 9 a part of vibration is shown. The time scale was compressed to show small peaks of speed.

The experiment with the oil tainted surface showed that the magnet was not attracted correctly. In some cases (Fig. 12) there was no useful signal from the magnet. The signal is close to the noise level. Thus we come to the conclusion, that essential condition for the correct operation of the device is a dry and metallic surface on which the tactile system is placed.

Conclusions

1. The device transmits information when the surface is metallic and dry.
2. The device fulfils 2 millimetres marginal value expectations.
3. For evaluation of the dynamic behaviour of the tactile system it is not enough 12 frames, analogous signal needed to fix movement.
4. The results showed that it is reasonable to study an influence of the vibration frequency to dynamic behaviour of the tactile system. The correct values of the signal frequency should be found.

Acknowledgments

Authors would like to thank Vilnius University Laser Research Center and especially professor Valdas Sirutkaitis for the technical and theoretical support in the measuring experiment. Also authors express their thankfulness to the Kaunas University of Technology Department of Mechanics, Institute of Defence Technologies, director professor Algimantas Fedaravičius for the rendered equipment for measurements.

References

1. **Tatara N., Mori M., Maeno T.** Method for eliciting tactile sensation using vibrating stimuli in tangential direction: effect of frequency, amplitude and wavelength of vibrating stimuli on roughness perception. Proc. International Symposium on Robotics. 2002. P. 42-47.
2. **Assamura N., Tomori N., Shinoda H.** A tactile feeling display based on selective stimulation to skin receptors. Proc. IEEE Virtual Reality Annual Int. Symposium '98. 1998. P.36-42.
3. **Gouzman R., Karasin I., Rozenblum D.** Mouse – like Input – output device with display screen and method for its use, WO 98/31005, PCT, WIPO, 1998.
4. **Sheshok A.** Aparatus for deaf-and-dumb, that transmit information in tactile way, design and analysis. Doctoral thesis. Vilnius. 2000. P.55-56.
5. **Howe R., Cutkowsky M.** Dynamic tactile sensing: Perception of fine surface features with stress rate sensing. IEEE Transactions on Robotics and Automation. 1993. Vol. 9. No.2. P. 235.
6. **Cranmer T. V.** A call for research on Braille reading and haptic perception. The Braille Monitor. NFB. 2002. Vol. 45. No 8. P. 22-25.

M. Ažubalis, R. Bansevicius, R. T. Toločka, V. Jurėnas

Taktilinio informacijos perdavimo įrenginio magnetinės pavaros tyrimas

Reziumė

Pateikiami taktilinio įrenginio matavimų duomenys, jo magnetinės pavaros judesio dinamikos bei ribinių padėčių fiksavimo eksperimentų rezultatai. Eksperimentai parodo pagrindines įrenginio charakteristikas: magnetinės pavaros ribines padėtis bei magnetinės pavaros inkarėlio elgseną informacijos perdavimo metu.

Pateikta spaudai 2004 08 31

DOI: 10.5755/j01.u.52.3.8359