

Application of ultrasound Doppler technique for blood velocity evaluation

A.Kopustinskas, G.Kopustinskiėnė

Department of Applied Electronics, Kaunas University of Technology

Studentų g. 50-303, LT-3031 Kaunas, Lithuania, Phone: +370 37 300271, Fax.: +370 37 351409, E-mail: akopus@ktu.lt

Introduction

Blood circulation acts a important role for ensuring suitable conditions for functioning live organisms. Cardiovascular disease is a major cause of death and disablement. A measurement of blood flow gives valuable diagnostic information about physiology state of organisms.

Ultrasound techniques for a blood flow diagnostics satisfy an important requirement of noninvasive measurements, acceptable for patients and medical authority.

The specifics of using acoustic waves in medical diagnostics is that these waves, propagating and reflected in tissues, are significantly transformed; their initial parameters are significantly changed. Tissues can be assumed as complicated non-linear filter, distorting wave's spectrum. Ultrasound contrast agents offers new modality of blood flow evaluation.

The actuality of blood flow evaluation problem shows numerous publications appearing in these latter years by Evans D. H., Burns P. N., Cobbold R. S., Jensen J. A. [1], Ferrara K. W., Tortoli P., Chen J. F. and others.

Further investigations are needed for development of angle tolerant velocity measurements methods, models, evaluation of mechanical parameters of blood vessels, increasing sensitivity and reliability of measurements.

The purpose of this study is the application oriented investigation of ultrasound continuous and pulse waves methods for blood flow evaluation and diagnostics, based on the Doppler signal spectral analysis. The main objects of this study were: to examine disc-ring transducers, to estimate an optimal ultrasound frequency for Doppler measurements, to analyse factors, having impact on accuracy and quality, to propose multipoint spatial blood flow model for investigation of interaction with an acoustic field, generated by a transducer and to examine techniques for ultrasound signal acquisition, Doppler signal processing and presentation.

The experimental blood flow sonogram, histogram and diagnostic parameters are presented in this study.

Doppler effect

The operation of the major modern diagnostic devices for blood flow evaluation is based on the ultrasound Doppler effect.

Blood flow measurement situation is shown in Fig. 1. When blood reflects ultrasound waves, the blood cells acts as waves receiver and at the same time as transmitter.

The Doppler shift of the frequency f_d of ultrasonic waves, backscattered by the moving blood particles -

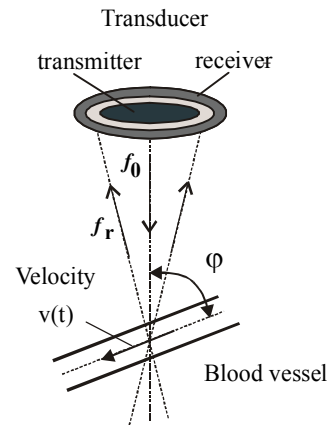

Fig. 1. Reflection of ultrasound waves from moving blood cells

erythrocytes, leukocytes - is proportional to the double velocity of movement. The blood velocity is the time function

$$v(t) = \frac{c_0 f_d(t)}{2 f_0 \cos \varphi}, \quad (1)$$

$$f_d(t) = f_0 - f_r(t),$$

where f_d is the Doppler shift frequency, φ is the Doppler angle, f_0 is the center (transmitted) frequency, $f_r(t)$ is the received frequency, $c_0 = 1540$ m/s is the velocity of ultrasound waves in tissue. The measurements of the blood flow velocity are carried out by detecting the frequency shift of the received signal. The transmitted frequencies are in the range 2-12 MHz and the Doppler frequencies are in the audible frequency range for a typical 0,01-5 m/s blood velocity, found in most blood vessels.

Transducers for Doppler measurements

Ultrasonic transducer has large influence on the quality of these devices. The principles of frequency selection for continuous and pulse waves systems are investigated. The main idea is to determine the optimal acoustic wave frequency taking into account wave intensity attenuation frequency characteristic of tissue, the Rayleigh scattering assumption for blood cells as a point scatters and the distance from the vessel. Two factors have an opposite effect upon the intensity of the reflected ultrasonic waves. According to the Rayleigh theory the intensity of the back-scattered waves will be proportional to the frequency powered to the 4th degree. By using a

simple phenomenological model often a linear dependence between attenuation and frequency is assumed with an attenuation increasing with frequency.

The backscattered and transducer affecting ultrasonic wave intensity frequency characteristic is expressed [2]:

$$I(f) = \frac{k_0 I_0 f^4}{10^{0.2 a_0 h f^b}} \quad (2)$$

where I_0 is the intensity of by waves transmitted transducer, when $h=0$ cm, where a_0 – attenuation coefficient of the wave amplitude (dB/cm MHz), h is the distance from the transducer to the blood flow, b is the radix that for most biological tissues is equal to 1.2 and for bones equals to 2.

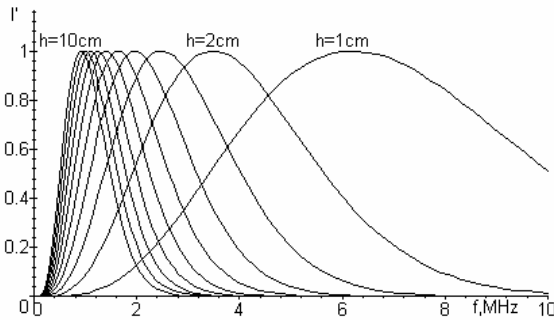

Fig. 2. The backscattered normalized ultrasonic wave intensity frequency response at different distances from the vessel ($a_0 = 0.81$ dB/cm MHz, $b=1,2$)

Let's define the concept of the optimal wave frequency. This is such a frequency, when for a given distance from the transducer the intensity of backscattered waves is maximal, corresponding to the maximum of the frequency response (Eq. 2).

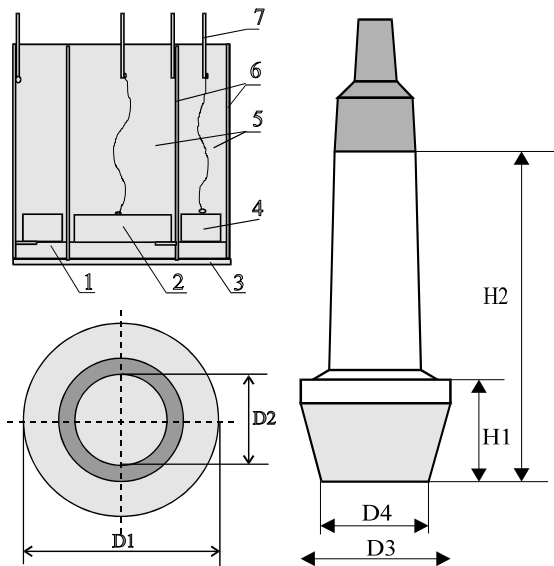

Fig. 3. Design of disc-ring Doppler transducer: 1-maching layer, 2-disc type piezoelectric crystal, 3-protector layer, 4-ring type piezoelectric crystal, 5-backing without damping layer, 6-insulating screen, 7-electrodes

Frequency characteristics determined by using Eq. 2, are shown in Fig. 2, where the distance from the transducer to the vessel varies from 1 to 10 cm. It implies that the optimal wave frequency varies from 6 to 1 MHz dependently on the depth of the vessel. For comparison we can say that waves' frequency, determined by recently used expression $f=90/h$, varies from 0,9 to 9,9 MHz and difference from the optimal value is about 1,2-1,5 times.

Table 1. The dimensions of the Doppler transducers

	2 MHz	4 MHz	8 MHz
D1, mm	14,8	12	8,0
D2, mm	9,0	7,2	4,8
D3, mm	23	19	16
D4, mm	18	15	12
H1, mm	24	17	17
H2, mm	84	76	76

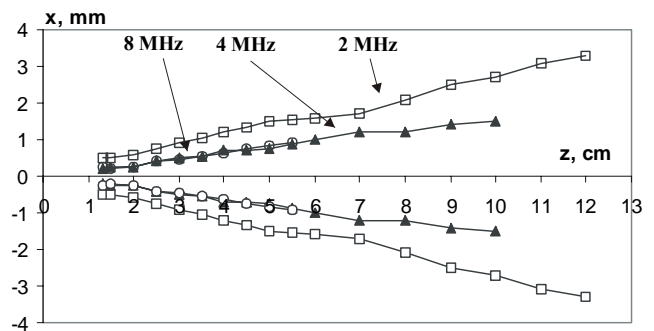

Fig.4. Experimental dependence of ultrasound beam width (50 % level) on the axial distance in water of different disc-ring Doppler transducers, shown in Fig. 3

The disk-ring ultrasound transducers for blood velocity measurements were developed. The peculiarity of this type construction (Fig.3) is self-focusing and quite narrow acoustic beam field diagram in the transmitting – receiving mode, allowing to improve the spatial-lateral resolution of the vessel. Experimental investigations show (Fig.4), that the width of a beam at the level of 50 % at the distance 10 cm in water is not bigger than 4 mm for the 2 MHz transducer and not bigger than 2 mm for the 8 MHz transducer.

Geometrical dimensions of transducers with different frequencies are presented in Table 1.

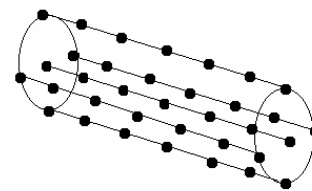

Fig. 5. The multipoint model of blood flow in the vessel

Spatial multipoint model of blood flow

The discrete spatial multipoint scatterers blood flow model was developed for simulation of ultrasound measurement technique [3].

The model allows simulation of received ultrasonic signals from blood, e.g., from an ensemble of scatterers. It's assumed that the vessel is a cylinder – pipe shape, and the inside it is filled by point scatterers uniformly or with a particular law of distribution, shown in Fig. 5. Point type scatterers distribution correspond to the real distribution of blood particles in a vessel.

The received signals depend on a number of factors – vessel geometry, the distance from a transducer, geometry of the ultrasound beam, the distribution of blood particles inside the vessel.

The vessel space fragment within the bounds of the ultrasonic beam is shown in Fig. 6. The scatterers are spread out on the lines, which are parallel to the vessel wall. The plain surface in Fig. 6 is perpendicular to the transducer surface and crosses its centre and the vessel axis. In the case of the incident signal that consists of a burst of sinusoidal oscillations the summarized high frequency signal from the blood particles is given by:

$$u(t) = \sum_1^m A_i \sin[2\pi(f_0 - f_d)t + \psi_i] \quad (3)$$

where i is the number of scatterer, A_i , ψ_i are the amplitude and the phase of the back-scattered signal from the i -th scatterer; m is the number of scatterers in a sample volume. For example, if the diameter of the vessel fragment $d = 1$ cm, the length is 6.5 cm and the distance between scatterers $\Delta l = 1$ mm, the number of scatterers is equal to 5301.

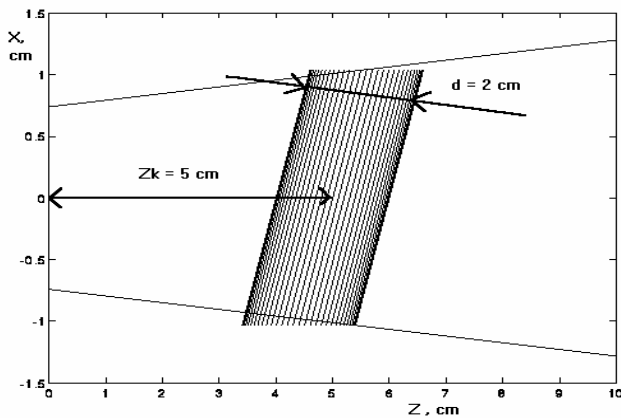

Fig. 6. The cross-section of the investigated space with a straight vessel; d -diameter of vessel, Z_k -distance from transducer to centre of vessel

It is reasonable to use the blood flow multipoint scatterer model because it allows to take into account three dimensional acoustic field amplitude and phase characteristics resulting in an increased quality of modelling.

The software for simulating the multipoint scatterers model was developed and used for analysis at two acoustic beam technique [3]. The influence of an ultrasound beam geometry and other factors to accuracy of volume flow measurements was investigated.

Continuous wave (CW) Doppler instrument

Various structures of Doppler instruments were investigated theoretically and experimentally [4, 5]. The block diagram of CW instrument is shown in Fig. 7. It has these specific features: narrowband amplifier, detection of blood flow direction; audio output, the two channel Doppler signal real time digital spectral analyzer (FFT); sonogram and diagnostic parameters of blood flow are calculated and visualized on the display. Investigations have shown that use of a narrow-band central frequency rejection filter (2) allows to decrease requirements for parameters of the phase frequency response of the demodulator, but contributes an additional measurement error in the range of low blood velocities, less than 0.1 m/s. The Doppler signal is detected using the quadrature demodulator (3, 4, 5). The analog adjustable blood wall and other filters (6, 7) reject unavoidable components from echo signal. The phase shifter (8) and summatoms (9, 10) form audio output signals. The disc-ring transducer generates symmetric acoustic field profile, focused in the axial direction.

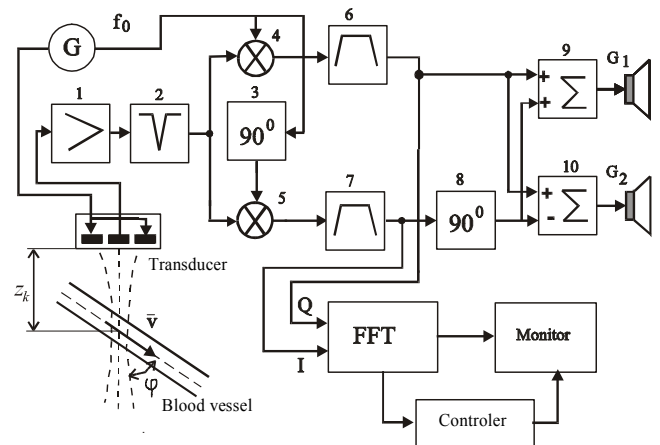

Fig. 7. Main functional modules of a continuous-wave Doppler instrument

The complex quadrature signal in the input of spectral analyzer is equal to the sum of the first channel signal Q and the second one I , multiplied by $j = \sqrt{-1}$:

$$X(t) = Q(t) + j I(t). \quad (4)$$

$$\begin{aligned} Q(t) &= 0.5A_f \cos \omega_f t + 0.5A_r \cos \omega_r t, \\ I(t) &= -0.5A_f \sin \omega_f t + 0.5A_r \sin \omega_r t, \end{aligned} \quad (5)$$

where A_f , A_r , ω_f , ω_r are the amplitudes and the frequencies of the Doppler signal from blood cells, moving towards and from the transducer. Analysis showed that sign of the signal, which is formed in this way, will produce negative spectrum components, which corresponds to the blood flow reverse direction.

Since ultrasound is back-scattered from moving blood cells with random distribution of concentration and velocities, the Doppler signal also is a random signal with a frequency spectrum reflecting this range of velocities.

The CW instrument has no limitations to measure maximal velocities. The Drawback of the device -

impossible to separate two vessels, located in axial direction.

Pulse wave (PW) Doppler instrument

The block diagram of a PW Doppler instrument is shown in Fig. 8. This device uses pulse-echo range measurement for the selection of Doppler signals from moving targets according to their distance from the ultrasonic probe.

The PW Doppler board incorporates a high frequency oscillator G , frequency divider, amplifier, phase quadrature detector (3, 4, 5, 6, 7), gate, sample and hold circuits (8, 9), vessel wall adjustable and low frequency filters (10, 11), phase shifter (12) spectral analyzer (FFT board), audio and visual outputs.

The depth and the length of the sample volume are controlled by the operator. A short burst of ultrasound is transmitted periodically and the output of the Doppler demodulator is sampled and hold after a delay following transmission. The device is sensitive to flow only within a small sample volume at a distance from the transducer. The same piezoelement of the transducer is used for transmission and reception of ultrasound wave.

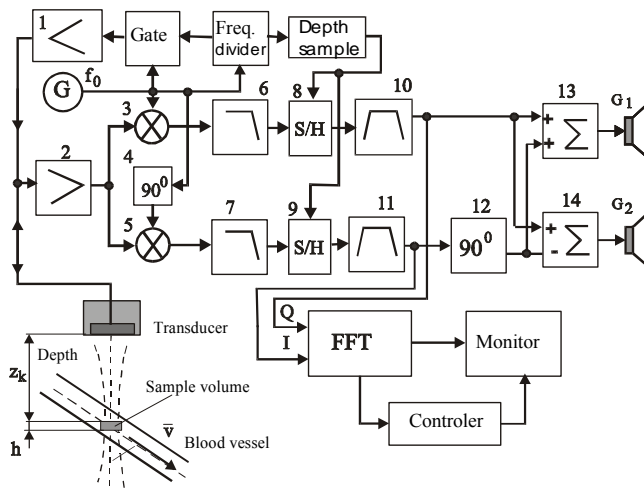

Fig.8. Main functional modules of the pulse-wave Doppler instrument

The drawback of the PW instrument is limited maximal flow velocity that may be detected. It is limited according to the Nyquist principle and depends on the central frequency and the depth of investigation z_k . The maximal flow velocity is given by

$$V_{\max} = \frac{c_0^2}{8z_k f_0} \tag{6}$$

The CW and PW Doppler instruments, which have no possibility to measure Doppler angle φ (1), sometimes are named as “blind” medical devices. In this case they give only relative (not absolute) measurement data.

Spectral density of Doppler signal

The blood cells move in the vessel with different velocities, so the frequency of acoustic waves, back-scattered from these particles, would differ. This implies that there is the spectrum of Doppler signal, which depends

on a place of wave reflection in the vessel cross-section and is proportional to the velocities of particles.

Various cases of spectrum were investigated when ultrasonic waves interact with the vessel [8]. If the whole cross-section of a vessel affected by a CW ultrasound beam, the Doppler signal spectral density is obtained:

$$S(f) = S_m \frac{1}{n} \left(1 - \frac{f}{f_m}\right)^{\frac{2-n}{n}} \cdot \left[1 - \left(1 - \frac{f}{f_m}\right)^{\frac{n_p}{n}}\right] \tag{7}$$

where n is the blood flow profile coefficient, n_p is the blood concentration coefficient of cells, $f_m = k_d V_M$ is the maximum Doppler frequency corresponding to a maximum velocity.

From Fig. 9 may be seen, that the Doppler signal spectral density profile significantly depends on the ratio of the ultrasound beam width and the vessel diameter. Therefore, results of the blood velocity evaluation in general depend on the width of an ultrasound beam, it's orientation and the blood vessel diameter.

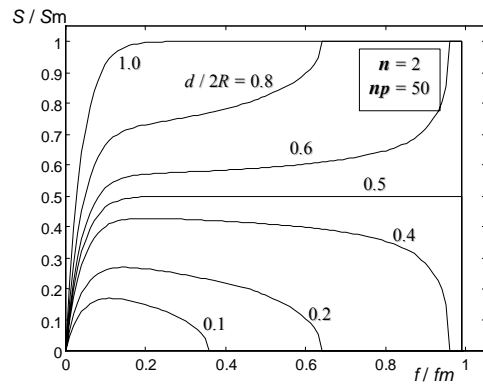

Fig. 9. Doppler signal normalized spectral density dependencies on width of acoustic beam probing the middle part of the cross section of a vessel, when the blood flow velocity is laminar-parabolic ($n=2$), R -radius of vessel, d -width of beam

Practical realization

The CW and PW Doppler instruments for blood flow evaluation were developed. The main functional modules of the instruments are shown in Fig. 7 and 8. Spectral analysis of Doppler signals in the real time is realized by using the DFT algorithm:

$$S(k) = \sum_{n=0}^{N-1} x(n) \cdot W_N^{k \cdot n} \tag{8}$$

$$x(n) = Q(n) + jI(n),$$

where $x(n)$ is n -th sample of the discrete complex amplitude of the input signal (4), $S(k)$ is the complex amplitude of the rated spectrum of k -th harmonics, $k = 0, 1, 2, \dots, N-1$; $W_N^{k \cdot n}$ is the turning multiplier; N is the number of entry signals count out harmonics of spectrum.

Two versions of the Doppler signal spectrum analyzer implementations were tested. Hardware of the analyzer is created on the high speed 16-bit multiplier-accumulator

base, its characteristics corresponded to the designed ones [7]. The maximum frequency of the signal spectrum of which is computable in the real time is 48 kHz. The software analyzer is created on PC base [6]. Beside the Doppler signal spectrum analysis, the software includes computing means of circulation of the blood diagnostic parameters, visualization of a sonogram in black/white and color palette and the users interface.

It is important to get the spectral information in the real time, because in this case a doctor can set the ultrasonic detector to the optimal position using feed-back and to fix the sonogram of the blood wave with the least artificial distortions.

Doppler spectral information has three dimensions (Fig. 10): frequency (velocity), magnitude (flow quantity) and time. This information was presented on a color display device. The biggest amount of data is received from two-dimensional (2D) blood velocity spectral sonogram showed in Fig. 11. Spectral information modulates the intensity of the display to give indication magnitude of the relative number of blood particles moving with a particular velocity. When representative spectral waveform is displayed, the image is frozen and it is used for further processing.

Analysis of Doppler signal spectrum enables detect: the flow direction, the velocity distribution, the temporal change of velocity; the maximum (highest), minimal and mean velocity.

Additional data for blood flow evaluation and analysis of a nature of flow are obtained by visualization of instantaneous distribution (histogram) of amplitudes of Doppler signal spectral components, shown in Fig. 11, a. The amplitude is proportional to the total amount of particles in a blood flow, moving with the appropriate velocity.

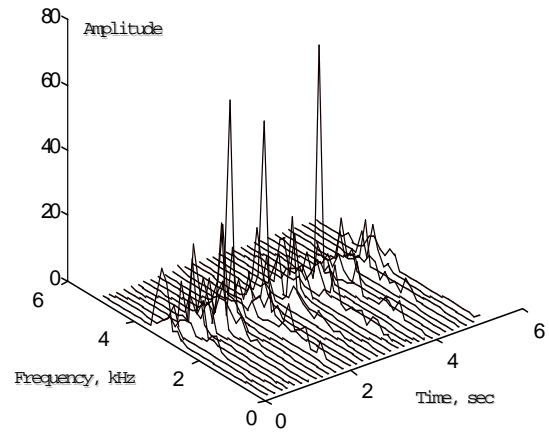

Fig.10. Three dimensional (3D) view of experimentally measured sonogram

The evaluation-diagnostic parameters of circulation of blood are calculated from the maximum and mean Doppler frequency dependence upon the time. The maximal frequency is defined as a frequency, when a sum of power spectral components with frequencies below, consists of 95% power of all spectral components. The maximal instantaneous frequency $f_{max}(t)$ is calculated from the following expression:

$$\int_0^{f_{max}(t)} S(f)df = \frac{100-p}{100} \int_0^{\infty} S(f)df, \quad (9)$$

where $p=5$.

The mean instantaneous frequency

$$f_{mean}(t) = \frac{\sum f_i A_i^2(t)}{\sum A_i^2(t)}, \quad (10)$$

where A_i is the amplitude of i -th frequency component f_i of the Doppler signal spectrum (Eq. 8).

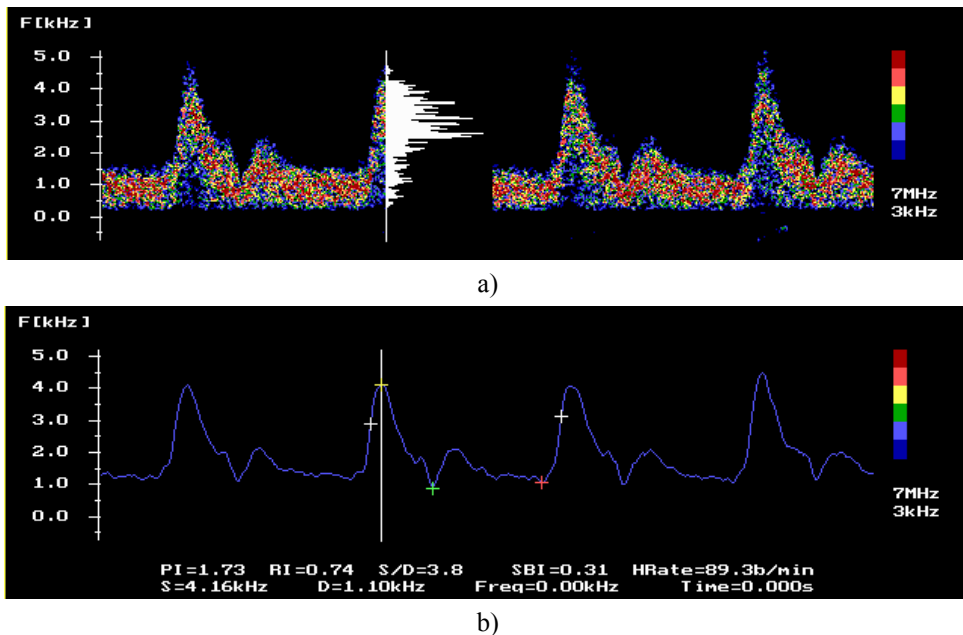

Fig. 11. Typical experimental characteristics of radial artery measured with the developed CW Doppler system; (a) - sonograma and histograma; (b) - maximal Doppler frequency dependence upon a time calculated from this sonogram, position of markers and evaluation-diagnostic parameters are calculated automatically

The spectral broadening index (*SBI*) indicates the level of flow turbulence in a users defined instant t' of cardiac cycle:

$$SBI(t') = \frac{f_{\max}(t') - f_{\text{mean}}(t')}{f_{\max}(t')}. \quad (11)$$

The reason of high turbulence (*SBI*) of a flow often may be the symptom of stenosis or aneurism of the vessel. The pulsativity index characterizes the elasticity of a vessel system:

$$PI = \frac{1}{P_0^2} \sum P_i^2 \cong \frac{f_m - f_{\min}}{f_{\text{aver}}}, \quad (12)$$

$$f_{\text{aver}} = \frac{1}{T} \int_0^T f_{\text{mean}}(t) dt,$$

where T is the duration of a cardiac cycle, f_m , f_{\min} , f_{aver} are the parameters of sonogram – maximal (systole), minimal and average frequencies, found from a maximal Doppler frequency dependence upon a time, shown in Fig. 11,b.

The resistivity index characterizes the resistance of peripheral vessels for a blood flow:

$$RI = \frac{f_m - f_{DT}}{f_m}, \quad (13)$$

where f_m is the maximal systole frequency, f_{DT} is the diastole frequency, defined at the end of a cardiac cycle. The systole and diastole frequencies ratio characterizes the dynamic range of cardiac activity:

$$S / D = \frac{f_m}{f_{DT}}. \quad (14)$$

In the sonograms it is seen rather big Doppler spectrum extension. When ultrasound waves are reflected from the parabolic or laminar flow, histogram has no one distinct harmonic.

The main technical data of the Doppler instruments are the following: the continuous wave mode frequency – 8MHz; the pulse wave mode frequency – 2 MHz; the pulse repetition frequency – 5kHz; the audio frequency range for loudspeaker – 0.1-12 kHz; the high pass filters – 100 Hz, 300 Hz, 1000 Hz; the radio frequency gain – 0–30 dB; the measurement depth – 8MHz–4 cm, 2MHz–10 cm; Doppler processor – 128 point complex FFT; the maximal calculation speed 1.5 ms, the frequency range +80Hz – +40 kHz; ultrasound intensity < 50 mW/cm².

The FFT board may be used as a universal digital high speed spectral analyzer for various applications.

Experimental verification “in vivo” with peripheral and transcranial vessels had shown that this instrument may be used for investigation and diagnostics of vascular diseases.

Conclusions

- disc-ring Doppler transducer generate in the axial direction quite narrow acoustic beam field in the transmitting – receiving mode, enabling improvement of spatial-lateral resolution;
- optimal acoustic wave frequency was proposed and it can be applied for determination of frequencies in Doppler blood flow evaluation instruments;

- the novel discreet spatial blood flow multipoint scatterers model was developed for modeling of new techniques for blood velocity evaluation and optimization of transducer characteristics;
- additional data for blood flow evaluation are obtained by visualization of instantaneous distribution (histogram) of amplitudes of Doppler signal spectral components;
- CW and PW Doppler instruments for evaluation of peripheral and transcranial blood velocities were designed and experimentally tested and are used for further investigations and other purposes.

References

1. **Jensen J. A.** Estimation of blood velocities using ultrasound. A signal processing approach.. Cambridge univ. press. 1996. P.317.
2. **Baronas A., Kopustinskas A.** Optimalaus ultragarso bangų dažnio nustatymas hemodinamikai tirti. Elektronika ir elektrotechnika.. Kaunas: Technologija. 1996.- Nr.5(9). P. 31 – 34.
3. **Kopustinskas A., Lukoševičius A., Mačiulis A.** Kraujo srauto matavimo, panaudojant dvigubą spindulį, modeliavimas ir analizė. Elektrotechnika ir elektronika. Kaunas: Technologija. 1995. Nr.1. P.9-20.
4. **Kopustinskas A.** Ultrasound Doppler system for blood velocity measurements. Proceedings of higher schools of Lithuania. Kaunas: Technologija. ULTRAGARSAS. 1993. Nr. 25. P. 105-113.
5. **Adaškevičius R., Kopustinskas A.** Modeling of blood flow measurement system elements. Proceedings of the 4th Biennial Conference. TTU, Estonia. Oct. 9-14, 1994. P.125-132.
6. **Tekorius T., Kopustinskas A., Mačiulis A.** Spectral analysis of Doppler ultrasonic flow signals by a personal computer in real time. KTU mokslo darbai: Automatika III. Kaunas: Technologija. 1994. P.31-36.
7. **Копустинскас А., Баронас А., Пилецкас Э.** Построение цифрового процессора для спектрального анализа ультразвуковых доплеровских сигналов в реальном времени. Научные труды Литвы: Ультрагарсас.1990. No 22. С. 81-92.
8. **Kopustinskas A.** Doplerinio signalo spektro modeliavimas. Elektronika ir elektrotechnika. Kaunas: Technologija. 1996. Nr.5(9). P.26 – 30.
9. **Tekorius T., Kopustinskas A.** Simulation and investigation of vessel wall movement by the use of mathematical model of blood vessel. Information technology and control.. Kaunas: Technologija. 1997. Nr.2(5). P. 45-49.

A. Kopustinskas, G. Kopustinskiene

Ultragarso Doplerio metodo taikymas kraujo tekėjimo greičiui nustatyti

Reziumė

Didinti kraujotakos įvertinimo patikimumą naudojant doplerinio signalo spektrinę analizę yra aktualu medicininei diagnostikai. Straipsnyje nagrinėjamos nepertraukiamų ir impulsinių ultragarso bangų doplerio metodų ypatybės, pateikiamos įtaisų schemotechnikos struktūros, doplerinių keitiklių charakteristikos, diagnostinių parametru skaičiavimo metodika ir eksperimentinės doplerinės sonogramos. Sudaryta optimalaus akustinių bangų dažnio nustatymo tiriant kraujotaką metodika, pasiūlytas diskretinis erdvinis daugiataškių atspindėtuvų modelis, kurį tikslinga taikyti modeliuojant naujus kraujo srauto įvertinimo metodus bei optimizuojant keitiklių charakteristikas. Parodyta, kad žiedinio-diskinio keitiklio konstrukcija pagrįsta simetrine, siaura ir aksialine kryptimi savaime fokusuota akustinio lauko kryptingumo diagrama. Palyginti su tipiniais dopleriniais įtaisais, papildomi nauji kraujotakos įvertinimo bei srauto pobūdžio analizės duomenys, gauti vizualizavus doplerinėje sonogramoje momentinį spektro dedamųjų amplitudžių pasiskirstymą (histogramą), atspindintį kraujo dalelių, judančių tam tikru greičiu, kiekį.

Pateikta spaudai 2004 09 14

DOI: 10.5755/j01.u.52.3.8362